



TECHNICAL BULLETIN

No: LA-501-006

Issue: 1

Date: 07 Jul 2005

CIRCULATE: TO

Service Mgr
X

Warranty
X

Workshop
X

Body Shop
X

Parts
X

SECTION: 501-08

A-pillar Water Leak

AFFECTED VEHICLE RANGE:

Land Rover LR3 (LA)

VIN: 5A000259 and up

CONDITION SUMMARY:

WATER INGRESS THROUGH A-PILLAR EXTERIOR TRIM ATTACHMENT HOLES

Situation: A customer may report water in the footwell of the vehicle. Water ingress through the lower slot in the A-pillar structure, where the exterior trim lower location peg slots into the body, may be the cause. The customer may also report unexplained illumination of warning lights such as the oil pressure warning lamp.

Action: If water ingress is confirmed from the A-pillar region on either side of the vehicle, BOTH sides of the vehicle must be repaired at the same time. Follow the Repair Procedure in this bulletin to remove the lower location pegs from the A-pillar exterior trim, cover the lower pin attachment slots in the A-pillar and install the trim using new clips in the special hardware kit available for the repair.

PARTS:

- | | | |
|------------------|--------------|------------------------------------|
| DHB500400 | Hardware Kit | Qty 1 per vehicle (CONTENTS BELOW) |
| • DZM000070..... | Clip | Qty 8 |
| • IPN500050..... | Clip | Qty 2 |
| • BNP3996 | Patch | Qty 2 |

WARRANTY:



NOTE: Repair procedures are under constant review, and therefore times are subject to change; those quoted here must be taken as guidance only. Always refer to DDW to obtain the latest repair time.

DDW requires the use of causal part numbers. Labor only claims must show the causal part number with a quantity of zero.

Description	SRO	Time (Hours)	Condition Code	Causal Part
Repair A-pillar water ingress	75.10.89/37	0.20	07	DCB000145PNP

Normal warranty policy and procedures apply.

NOTE: The information in Technical Information bulletins is intended for use by trained, professional technicians with the knowledge, tools, and equipment required to do the job properly and safely. It informs these technicians of conditions that may occur on some vehicles, or provides information that could assist in proper vehicle service. The procedures should not be performed by "do-it-yourselfers."
If you are not a Retailer, do not assume that a condition described affects your vehicle. Contact an authorized Land Rover service facility to determine whether the bulletin applies to a specific vehicle.

REPAIR PROCEDURE

SEAL A-PILLAR MOUNTING HOLES AND REINSTALL BOTH A-PILLAR MOUNDINGS

⚠ CAUTION: Repair procedure should be applied to both sides of the vehicle whenever an A-pillar leak is confirmed. The repair kit includes the appropriate parts to perform the procedure for **both sides**.

1. Confirm the source of the leak is the A-pillar area.
2. Release the A-pillar moulding trim clips and remove the A-pillar trim on both sides of the vehicle. (Figure 1)
3. Remove and discard the retaining clips from the upper locations on the back of the A-pillar trim.
4. Remove and discard the foam washer from the bottom peg. (Figures 2)

△ NOTE: The lower peg must be cut flush with the surface of the trim piece to ensure no protrusion will interfere with the A-pillar bodywork or the newly installed seal.

5. Cut the lower location peg from the A-pillar trim. (Figure 3)

Figure 1

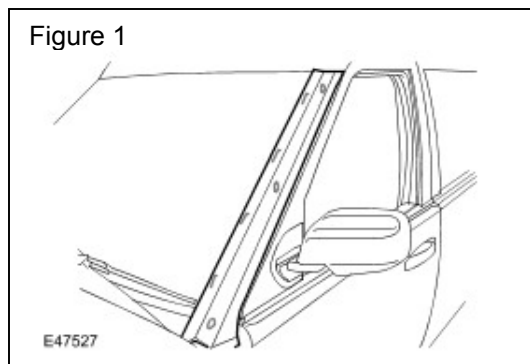

Figure 2

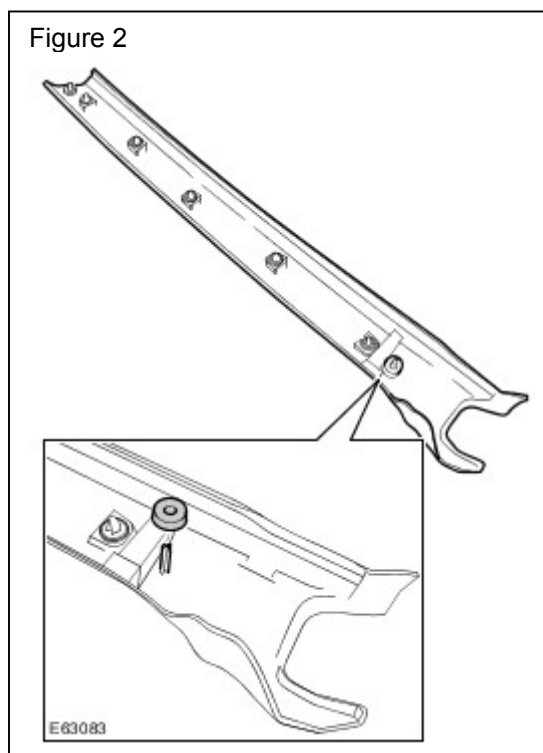
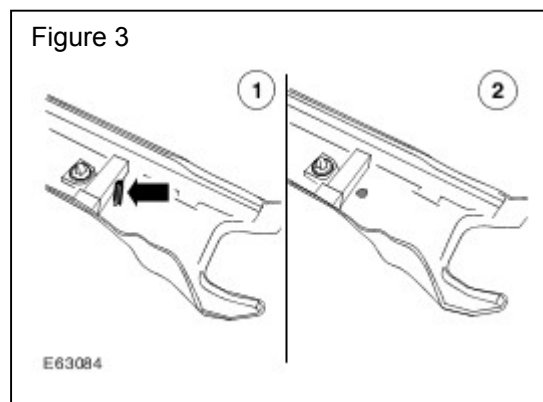

Figure 3



⚠ CAUTION: The area to which the adhesive patch is applied must be clean and dry before patch installation. The patch must completely adhere to the body surface to ensure a proper seal.

6. Clean area surrounding the lower elongated slot in A-pillar structure
7. Apply adhesive patch, supplied in kit DHB500400, to body covering lower elongated slot. (Figure 5)
8. Attach clip IPN500050 to the lowermost A-pillar exterior trim mounting location. (Figure 6)
9. Install 4 clips (DZM000070) to the remaining A-Post exterior trim mounting locations. (Figure 7)

⚠ CAUTION: Care must be taken not to cause damage to the clips when installing the exterior trim.

10. Carefully install the A-pillar exterior trim to the body.
11. Verify that clips have engaged the A-pillar body openings and that the trim is securely retained.
12. Repeat steps 3 to 11 on the un-repaired side of the vehicle.

Figure 5

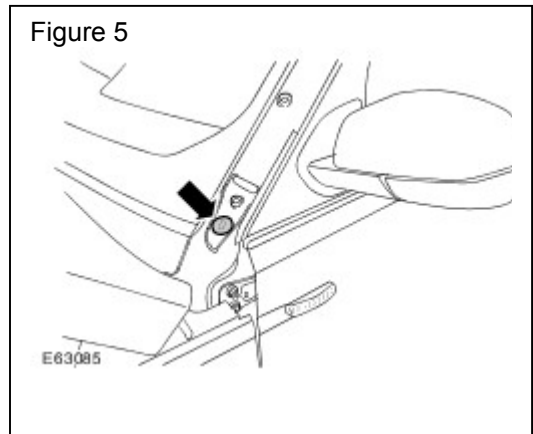

Figure 6

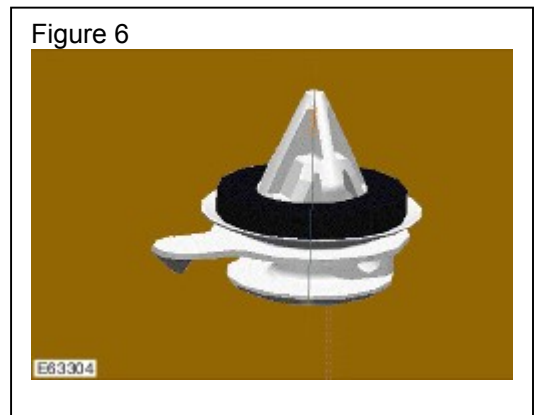

Figure 7

