

Water heaters

Workshop Manual

Thermo Top V

Type Thermo Top V (Petrol)

Type Thermo Top V (Diesel)

Improper installation or repair of Webasto heating and cooling systems can cause fire or the leakage of deadly carbon monoxide leading to serious injury or death.



To install and repair Webasto heating and cooling systems you need to have completed a Webasto training course and have the appropriate technical documentation, special tools and special equipment.

NEVER try to install or repair Webasto heating or cooling systems if you have not completed a Webasto training course, you do not have the necessary technical skills and you do not have the technical documentation, tools and equipment available to ensure that you can complete the installation and repair work properly.



ALWAYS carefully follow Webasto installation and repair instructions and heed all WARNINGS.

Webasto rejects any liability for problems and damage caused by the system being installed by untrained personnel.

Table of Contents

1	Introduction	101
1.1	Contents and purpose	101
1.1.1	Using water heaters	101
1.2	Meaning of signal words	101
1.3	Additional documentation to be used	101
1.4	Statutory regulations and safety instructions	101
1.4.1	General safety instructions	101
1.4.2	Statutory regulations governing installation	102
1.4.3	General information	102
2	General description	201
2.1	Combustion-air fan unit/control unit	201
2.2	Diesel/petrol burner	202
2.2.1	Fuel preheating (diesel burner with FPH only)	203
2.2.2	Solenoid valve (diesel burner with SV only)	203
2.3	Temperature sensor and overheating sensor	204
2.4	Heat exchanger	204
2.5	Circulating pump	204
2.6	Metering pump	205
3	Description of operation	301
3.1	Switching on/starting process	301
3.2	Heating mode	301
3.3	Restarting after fault lock-out	301
3.4	Starting after long period of non-use	302
3.5	Switching off/Switch-off function	302
4	Technical data	401
5	Troubleshooting	501
5.1	General error symptoms	501
5.1.1	Fault analysis on heater and components	501
5.2	Faults	503
5.2.1	Fault lock-out due to fault on heater	503
5.2.2	Fault lock-out due to undervoltage or overvoltage	503

6	Operating tests	601
6.1	General	601
6.2	Operating checks in vehicle	601
6.2.1	Testing heating mode	601
6.2.2	Setting CO2 content	601
6.3	Operating test in workshop	602
6.3.1	Testing individual components	602
6.3.1.1	Testing fan unit	602
6.3.1.2	Testing fuel preheating	602
6.3.1.3	Testing solenoid valve	602
6.3.1.4	Electrical test of glow plug	603
6.3.1.5	Testing temperature sensor and overheating sensor	603
7	Circuit diagrams	701
7.1	General	701
7.2	Legend for wiring diagram	703
8	Servicing work	801
8.1	General	801
8.2	Work on the heater	801
8.3	Work on the vehicle	801
8.4	Heater trial	801
8.5	Servicing work	801
8.6	Visual inspections and installation instructions	801
8.6.1	Connection to vehicle cooling system	801
8.6.2	Connection to vehicle fuel system	802
8.6.2.1	Fuel lines	802
8.6.2.2	Metering pump	802
8.7	Heater, removal and installation	804
8.7.1	Removal	804
8.7.2	Installation	804
8.8	Initial start-up	804
9	Repair	901
9.1	General	901
9.2	Dismantling and assembling	901
9.2.1	Dismantling heater	901
9.2.2	Assembling heater	902
9.2.3	Installing water connection piece variants	902
9.2.3.1	Installing water connection-piece variant A with teeth	902
9.2.3.2	Installing water connection-piece variant B without teeth	903
9.2.4	Dismantling combustion-air fan unit	903
9.2.5	Removing burner	903
9.2.6	Cable routing for glow plug on burner	904
9.2.7	Installing burner	904
9.2.8	Removing temperature sensor and overheating sensor	904
9.2.9	Installing temperature sensor and overheating sensor	905
9.2.10	Heat exchanger	905

10	Packing, Storage and Shipping	1001
10.1	General	1001
10.2	Storage	1001
10.3	Transport	1001

List of illustrations

Fig. 201	Cross-sectional functional model of Thermo Top V water heater	201
Fig. 202	Combustion-air fan unit	201
Fig. 203	Standard connector plate with AMP connector basket	202
Fig. 204	Connector plate with FEP connector basket	202
Fig. 205	Connector plate for VW single board with FEP connector basket	202
Fig. 206	Diesel burner with solenoid valve (SV)	202
Fig. 207	Diesel burner with fuel preheating (FPH)	202
Fig. 208	Diesel burner without fuel preheating	203
Fig. 209	Petrol burner with guard plate	203
Fig. 210	Petrol burner without guard plate	203
Fig. 211	Fuel preheating	203
Fig. 212	Solenoid valve	204
Fig. 213	Heater with temperature sensor and overheating sensor	204
Fig. 214	Heat exchanger	204
Fig. 215	Circulating pump	204
Fig. 216	DP40/DP41 metering pump	205
Fig. 301	Start-up process for Thermo Top V	301
Fig. 302	Unlocking heater	302
Fig. 401	Technical data for Thermo Top V	401
Fig. 402	Technical data for circulating pump	401
Fig. 501	Overview of possible faults	501
Fig. 502	Overview of functional analysis of heater and components	502
Fig. 601	CO2 setting	601
Fig. 602	CO2 setting values	602
Fig. 603	Resistance values for fuel preheating	602
Fig. 604	Resistance values of temperature sensor and overheating sensor	603
Fig. 701	Connector assignment of heater	701
Fig. 702	Wiring diagram of Thermo Top V additional heater and 12 V digital timer	702
Fig. 801	Circulating pump U4849 and U4847 ECON installation positions	801
Fig. 802	Pipe/hose connections	802
Fig. 803	Installation position of DP40/DP41 metering pump	802
Fig. 804	Information sign of DP40/DP41 metering pump	803
Fig. 901	Dismantling heater	901
Fig. 902	Installing air-intake and exhaust connection piece	902
Fig. 903	Installing water connection-piece variant A with teeth	902
Fig. 904	Installing water connection-piece variant B without teeth	903
Fig. 905	Detail of lock on water connection-piece variant B without teeth	903
Fig. 906	Removing and installing burner	903
Fig. 907	Cable routing of glow plug	904
Fig. 908	Cable routing of glow plug	904
Fig. 909	Heat exchanger	905
Fig. 910	Cable routing for temperature sensor and overheating sensor with water connection-piece variant A	906
Fig. 911	Cable routing for temperature sensor and overheating sensor with water connection-piece variant B	906
Fig. 1001	Preferred position of TT-V heater for storage and transport	1001

1 Introduction

1.1 Contents and purpose

This workshop manual supports personnel trained by Webasto, who are responsible for repairing the Thermo Top V auxiliary and additional water heaters in the petrol and diesel versions.

This manual applies exclusively for the repair of heaters, which are only installed with a vehicle-specific vehicle kit or directly at the vehicle manufacturer's plant as original equipment.

1.1.1 Using water heaters

The Thermo Top V water heater was designed for installation in Class M1 motor vehicles. Installation in Class O, N2, N3 motor vehicles and hazard substances transports in accordance with the EC Directive 70/156/EEC and/or EC/2007/46 (for new vehicle models from 29/04/2009) is not permissible. The applicable regulations must be taken into account when installing in special vehicles. No other uses are permissible.

The Thermo Top V auxiliary water heater is used to compensate the heat deficit on consumption-optimised vehicle engines and can be upgraded to an additional/auxiliary heater with an upgrade kit.

The Thermo Top V additional water heater is used:

- to heat the vehicle interior,
- to defrost the vehicle windows,
- to preheat water-cooled vehicle engines.

The heaters are marked on the type label with the text "Petrol" or "Diesel". The heaters may only be operated with the fuel specified on the type label (for information on diesel and petrol fuel, see Chapter 4) and only with the respectively specified type of electrical connection.

1.2 Meaning of signal words

Throughout this manual, the signal words WARNING, IMPORTANT and NOTE have the following meanings:

WARNING

This heading is used to highlight operating instructions or procedures which, if not or not correctly followed, may result in personal injury or fatal accidents.

IMPORTANT

This heading is used to highlight operating instructions or procedures which, if not or not correctly followed, may result in damage to the equipment or its components.

NOTE

This heading is used to direct your attention to a special feature deemed essential to highlight.

1.3 Additional documentation to be used

This workshop manual contains all necessary information and instructions for the repair of Thermo Top V water heaters.

Normally, there is no need to use additional documentation. If necessary, the operating instructions and/or the installation suggestion for the specific vehicle may also be used. When working on OEM heaters and performing diagnostic work on them, the instructions of the respective vehicle manufacturer must be followed.

1.4 Statutory regulations and safety instructions

1.4.1 General safety instructions

In principle, the general accident prevention regulations and current works safety instructions are applicable.

Any special safety regulations relevant to this instruction manual will be highlighted in the relevant sections or text passages of the procedures.

The repair and commissioning of the unit may only be carried out by personnel trained by Webasto. The unit may only be installed professionally in accordance with the installation instructions.

The heater must not be operated:

- In filling stations and tank farms.
- At locations at which highly flammable gases or dusts can form, and at locations at which highly flammable liquids or solid materials are stored (e.g. near fuel, coal and wood dust, grain warehouses, dry grass and leaves, cardboard, paper, etc.).
- In closed rooms (e.g. garages), not even via the timer or Telestart.

The heater:

- may not be subjected to temperatures of more than 120 °C (storage temperature).
- must be operated with at least a 20 % mix of a brand-name antifreeze in the water of the heating circuit.
- may only be operated with the fuel and the nominal voltage specified on the type label.
- must be shut down by immediately switching off the heater and removing the fuse in case of heavy smoke, unusual combustion noises or fuel odours. Restarting may only be carried out by personnel trained by Webasto after the unit has been checked.

- Must be put into operation at least once a year for 10 minutes with the engine cold and the lowest fan speed selected.
- Must be checked by a professional every 2 years, at the commencement of the heating period.

Warranty and liability claims:

- A failure to observe the vehicle-specific installation instructions/operating instructions and the information contained in them will result in the warranty being voided by Webasto. The same applies if repairs are carried out incorrectly or with the use of parts other than genuine spare parts. This will result in the invalidation of the type approval for the heater and therefore of its homologation / EC type licence. In addition, we shall also exclude our liability for slightly negligent violations of duties, provided damages from injury to life, body or health or guarantees are not affected or claims in accordance with the applicable product liability laws are not concerned. Also unaffected by this is the liability for the violation of duties which, when fulfilled, enable the proper execution of the contract in the first place and in the regular fulfilment of which the customer may place its trust. The same applies to violations of duties by our vicarious agents.

1.4.2 Statutory regulations governing installation

For the Thermo Top V heater there are homologation approvals in accordance with the EC Directives 72/245/EEC (EMC) and 2001/56/EC (heating) with the EC approval numbers:

e1*72/245*2006/96*1232*__
e1*2001/56*2006/119*0018*__

Installation is governed above all by the provisions in Annex VII of Directive 2001/56/EC and the regulations in accordance with the installation instructions.

NOTE:

The specifications of this Directive are binding in the scope of the Basic Directive EEC/70/156 and/or EC/2007/46 (for new vehicle models from 29/04/2009) and should also be observed in countries in which no special regulations exist.

1.4.3 General information

Some vehicle manufacturers have provided components like the auxiliary/additional heater with component protection. On these vehicles the new unit must be activated after replacing the unit at a specialist workshop of the respective manufacturer.

Please note that this is generally linked to low additional costs for the customer.

2 General description

The heaters operate in accordance with the venturi principle and use the physical effects of film evaporation and droplet evaporation for the processing of the fuel-air mixture.

After reaching a coolant temperature of approx. 80 °C, the heater switches from full load to partial load. In this operating mode the heater runs especially quietly and more efficiently with regards to electrical and fuel consumption.

The heater consists of the combustion-air fan unit with the control unit, the heat exchanger with the water connection piece and the venturi burner.

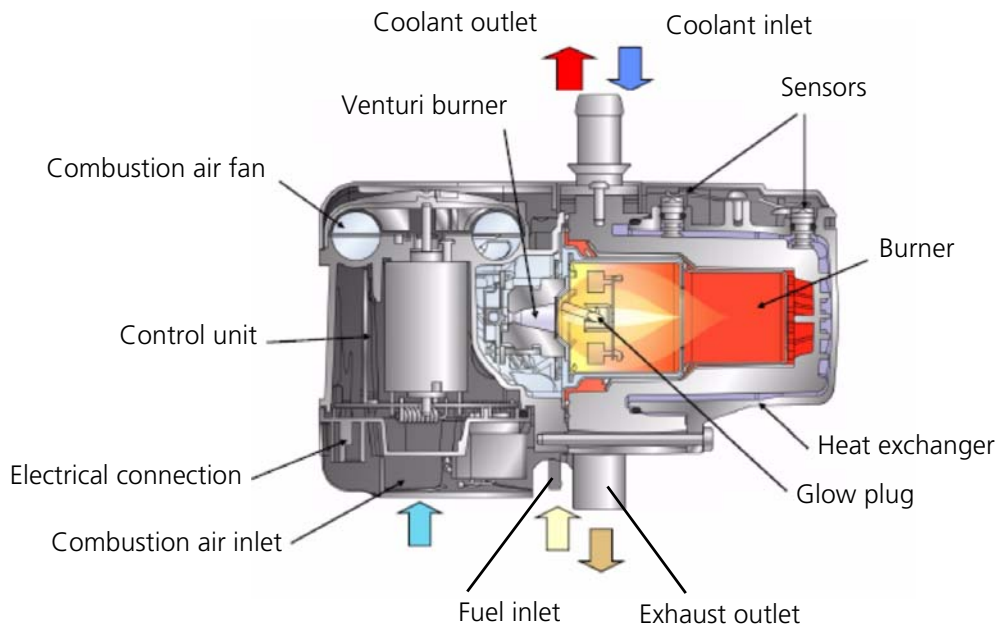

Fig. 201 Cross-sectional functional model of Thermo Top V water heater

2.1 Combustion-air fan unit/control unit

The combustion air fan supplies the air required for the combustion process from the combustion air inlet to the combustion chamber. The combustion-air fan unit contains:

- the heater type label
- the opening for the combustion-air connection piece and the combustion air pipe
- the control unit with the plug-in contacts for the electrical contact
- the engine and the impeller

For information on checking the fan unit, see section 6.3.1.1.

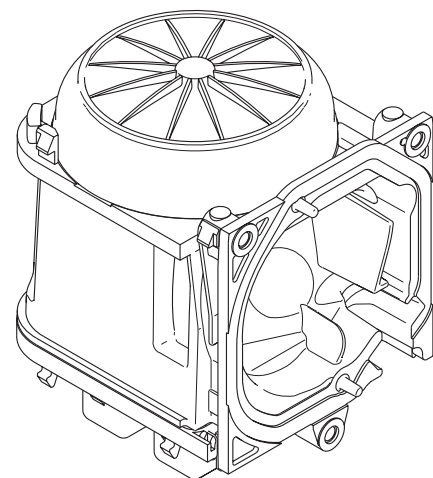

Fig. 202 Combustion-air fan unit

Connector plate variants

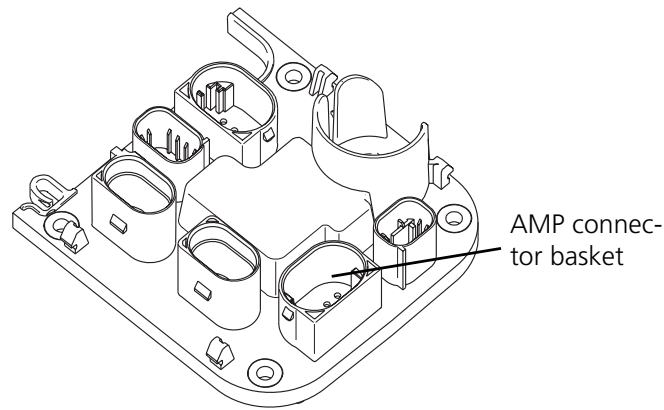

Fig. 203 Standard connector plate with AMP connector basket

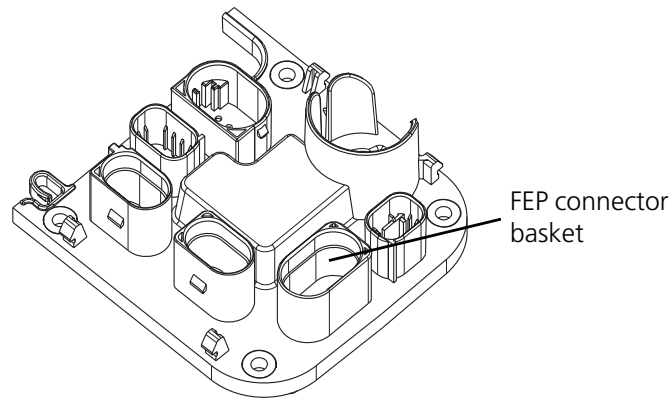

Fig. 204 Connector plate with FEP connector basket

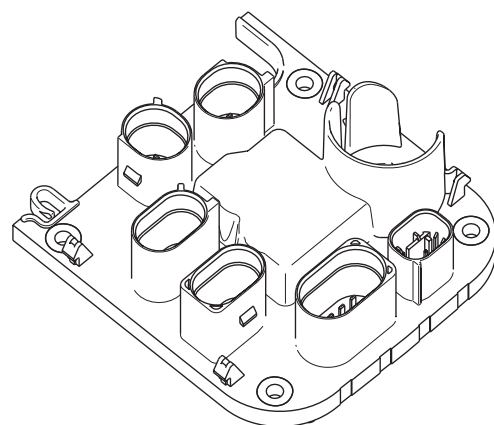

Fig. 205 Connector plate for VW single board with FEP connector basket

For connector assignment on control unit, see section 7.1.

2.2 Diesel/petrol burner

The processing of the fuel-air mixture and the actual combustion take place in the burner. The fuel flows into the pre-heating chamber with the shut-off valve opened, where it is at first heated up. After exiting from the fuel needle, it is atomised in a venturi nozzle through which primary air flows. Additionally directed secondary air is routed into the combustion chamber via the heat shield. The pilot flame is ignited on the hot spot of the glow plug and then, after slowly running up, leads to the ignition of the flame in the full load operating mode. In the process, the heater is dependent on the most bubble-free fuel delivery possible. The start process differs in different ambient temperatures ensuring that the heater starts with the minimum of smoke emission.

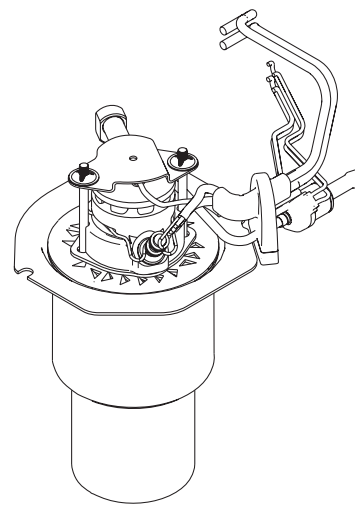

Fig. 206 Diesel burner with solenoid valve (SV)

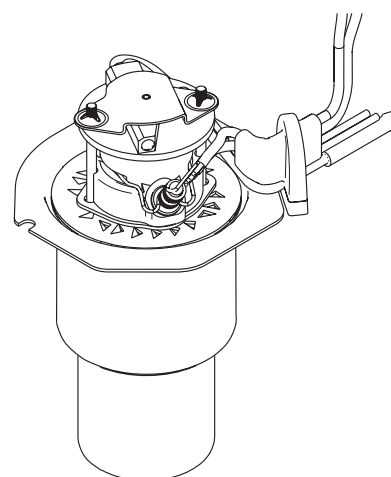

Fig. 207 Diesel burner with fuel preheating (FPH)

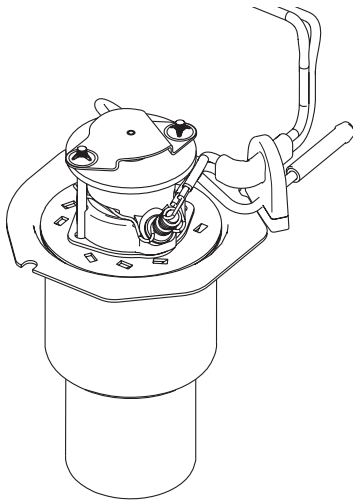

Fig. 208 Diesel burner without fuel preheating

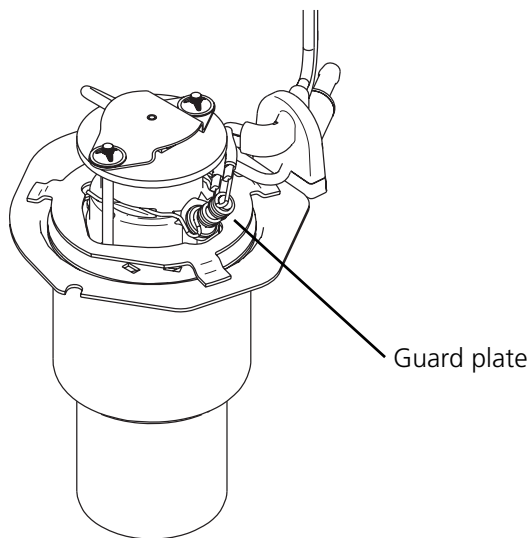

Fig. 209 Petrol burner **with** guard plate

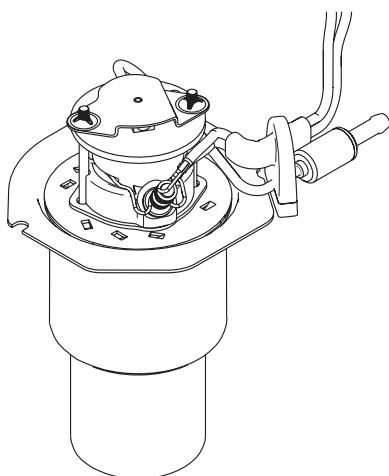

Fig. 210 Petrol burner **without** guard plate

For information on removing and installing the burner, see section 9.2.5 and 9.2.7.

IMPORTANT

Ensure that the correct burner is always used, as otherwise malfunctions and/or damage will occur on the heater and its service life will be reduced!

2.2.1 Fuel preheating (diesel burner with FPH only)

The fuel flows in a spiral in the preheater between a threaded sleeve and a smooth outer sleeve and is heated by an electrically operated heating cartridge during starting. Preheating is briefly activated in the burn-out with a low output to be able to burn the remaining fuel after the unit is switched off.

For information on checking fuel preheating, see section 6.3.1.2.

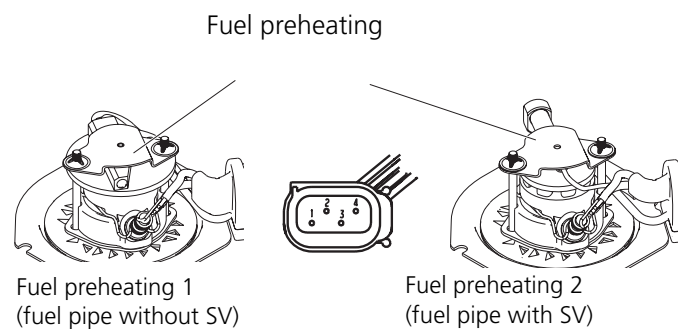

Fig. 211 Fuel preheating

2.2.2 Solenoid valve (diesel burner with SV only)

The solenoid valve is only used with a certain diesel heater variant. It ensures that fuel is routed into the combustion chamber at the correct time in the start-up phase. When the heater is switched off, the solenoid valve is intended to prevent any fuel from flowing into the combustion chamber.

For information on checking the solenoid valve, see section 6.3.1.3.

NOTE

The solenoid valve cannot be removed

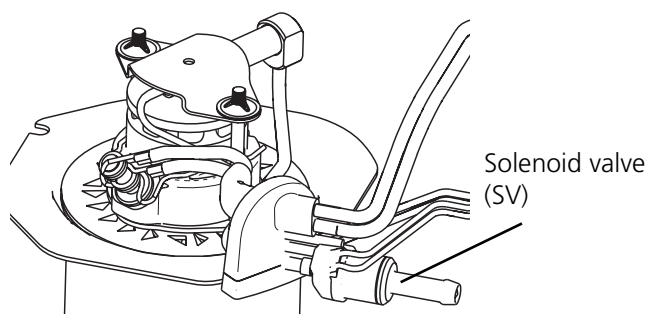

Fig. 212 Solenoid valve

2.3 Temperature sensor and overheating sensor

The temperature sensor detects the coolant temperature in the heat exchanger of the heater as an electrical resistance. This signal is fed to the control unit, where it is processed. The temperature sensor G1 (NTC) and the overheating sensor G2 (PTC) form a unit together with the cable and the connector.

The overheating sensor protects the heater against impermissibly high operating temperatures. This reacts at a housing temperature above 125 °C and switches off the heater.

For information on checking the sensors, see section 6.3.1.5.

For information on dismantling and assembly, see section 9.2.8 and 9.2.9.

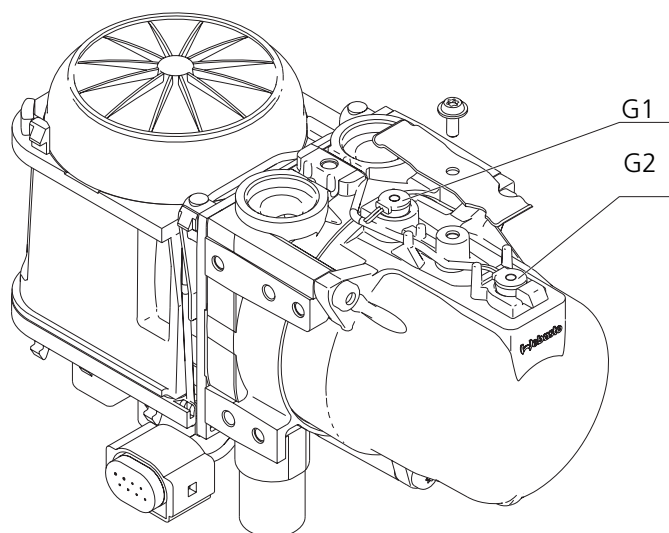

Fig. 213 Heater with temperature sensor and overheating sensor

2.4 Heat exchanger

The heat generated in the heat exchanger by combustion is transferred to the coolant circuit.

The heat exchanger consists of an inner and an outer section, which are sealed off with an O-ring. The inner section and the outer section are interconnected with a press fit.

For information on removing and installing the heat exchanger, see section 9.2.1 and 9.2.2.

For information on maintenance, see section 9.2.10.

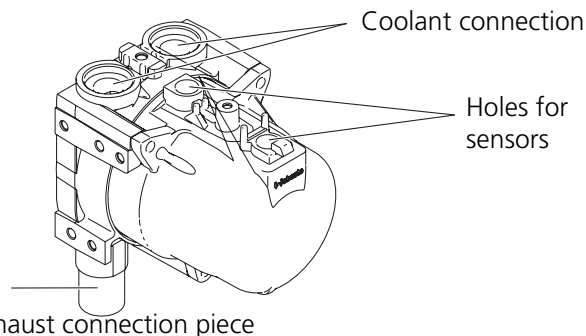

Fig. 214 Heat exchanger

2.5 Circulating pump

The circulating pump U4849 ensures a feed rate of the coolant in the vehicle or heater circuit. The pump is switched on with the control unit and runs during the entire operation of the heater.

For information on checking and installing the circulating pump, see section 8.6.1.

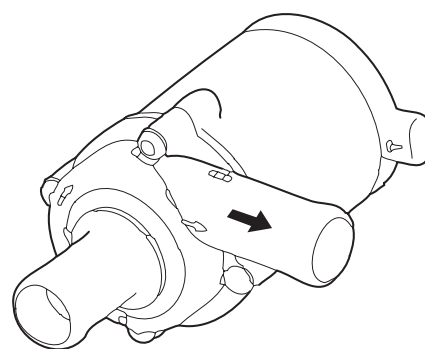

Fig. 215 Circulating pump

2.6 Metering pump

The metering pump is a combined transport, metering and shut-off system for supplying fuel from the vehicle's tank to the heater.

For information on checking and installing the metering pump, see section 8.6.2.2.

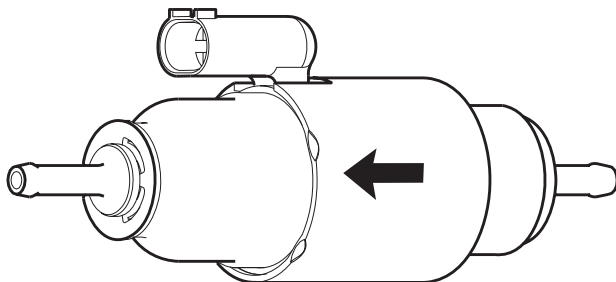

Fig. 216 DP40/DP41 metering pump

3 Description of operation

3.1 Switching on/starting process

The heater start-up can be carried out for the additional heater via a remote control element, the immediate heat button or timer programming of the clock.

For the auxiliary heater, the start-up is triggered by the presence of previously specified switch-on conditions (generally from an outside temperature below 5 °C) via the vehicle data bus.

Depending on the coolant temperature (and the engine temperature, if provided for), the control unit decides which start-up process is selected. Start-up processes are identical with regard to the sequence, however differ in the length of the individual phases (preheating, fuel delivery, etc.).

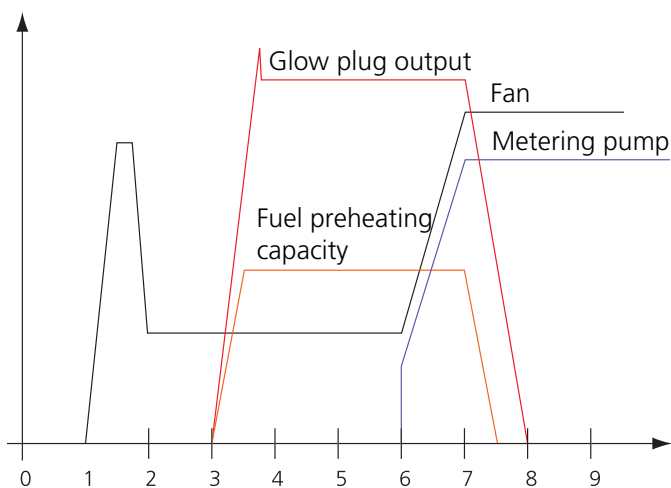

- 0) Heater On
- 1) Fan motor operating check
- 2) Checking resistance of glow plug/flame monitor
- 3) Preheating of glow plug
- 4) Selection of start-up process 7 to 9 via coolant temperature (Start 6: warm start, Start 4 control break start)
- 5) Glowing of glow plug with resistance control
- 6) Fuel delivery (Phase 1 to 6 at full load)
- 7) Switching off of glow plug (glow plug ramp)
- 8) Flame-monitor measuring phase
- 9) Combustion operation at full load (5 kW)

Fig. 301 Start-up process for Thermo Top V

After the heater has been switched on, the glow plug and the combustion air fan are put into operation. Then the metering pump is connected and the heater is run up to approximately full load in a ramp. During this start-up phase, it is checked whether a flame has formed with the glow plug via a output measurement. After full load is reached, the glow plug assumes the function of the flame monitor and checks the flame.

If no flame is formed or a flame out occurs, then a repeat start-up is initiated depending on the amount of fuel delivered. If once again no flame is formed, the fuel delivery is finished and a fault lock-out with run-on of the combustion air fan is carried out. The heater can then only be put into operation again as described in Paragraph 3.3.

If a flame out occurs during normal combustion operation, a restart is automatically initiated.

3.2 Heating mode

Depending on the customer-specific requirements, the heater switches into the energy-saving partial load mode after reaching a certain temperature (approx. 80 °C). If the temperature of the cooling liquid continues to drop due to an increased heat requirement during partial load operation, then the heater switches over to full load operation again. If the temperature continues to increase, the heater switches into the control break from a pre determined temperature (approx. 90 °C).

After the coolant has cooled down (to approx. 75 °C), the heater restarts in the full load or partial load mode. If the temperature rises to a defined switching temperature again, the heater switches into the partial load mode or control break again.

The temperature of the switching points is programmed in the control unit for the specific vehicle. In isolated cases, the control temperatures may have been set so that no partial load mode takes place.

3.3 Restarting after fault lock-out

If a fault occurs, the heater switches into the fault lock-out mode. After eliminating the fault cause, the heater can be restarted by switching it off and then on again.

This does not apply after overheating or if a fault occurs several times (generally 3x) without intermediate combustion operation.

In case of a heater lock-out, the fault must be identified with the Webasto Thermo Test PC diagnosis, the fault memory must be printed out and the faults must be deleted. Then the cause of the fault must be eliminated. Before starting the heater, the heater lock-out must be released by removing the 20 A fuse as described below (also see Fig. 302).

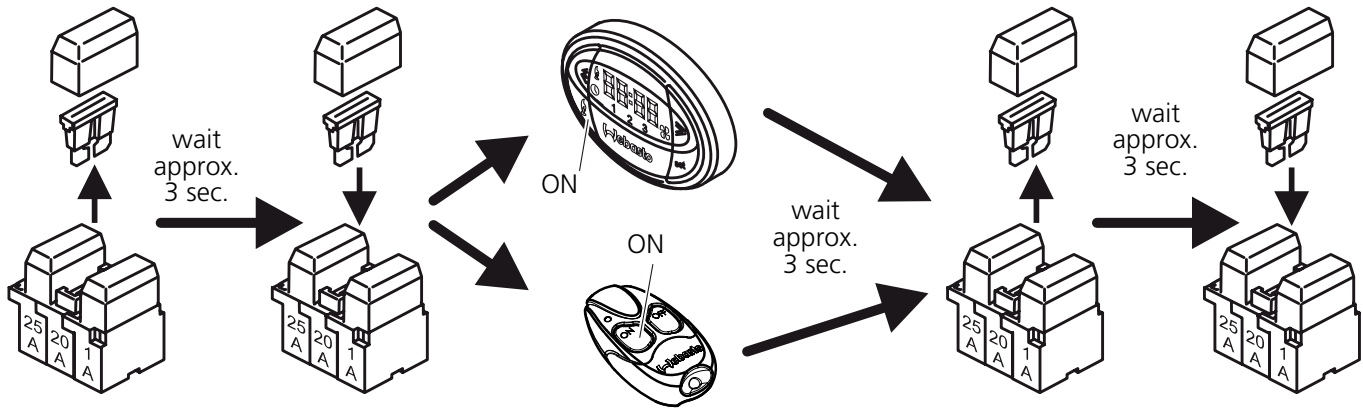

Fig. 302 Unlocking heater

1. Voltage interruptions by removing the 20 A fuse (yellow) in the heater-unit wiring harness (ongoing processes in the control unit are ended)
2. Refit the fuse
3. Briefly press the button on the transmitter or the flame button on the digital timer (heater switches into the heater lock-out state)
4. Interrupt the voltage by removing the 20 A fuse (yellow) in the heater-unit wiring harness (heater lock-out is released)
5. Refit the fuse (heater in the OFF state)

To start the heater, it must be switched on again!

NOTE

If no Webasto Thermo Test PC diagnosis is available, the lock-out can also be released without deleting the fault. As the fault will not be identified without PC diagnosis, it cannot be specifically eliminated and the heater goes into the lock-out mode again during the next start-up.

NOTE

As the Thermo Top V auxiliary heater is not switched on with a heater control, but instead receives the On signal when the vehicle engine is started, it must be started via the PC diagnosis following the repairs. To start the heater, the coolant temperature should not be above 40 °C.

3.4 Starting after long period of non-use

Longer periods of non-use generally have no effect on the starting function of the heater. However, limitations must be made here with regard to filling of the fuel lines. Especially with petrol heaters, the fuel evaporates from the fuel line in the summer months. As a result, it must be expected that several complete starting attempts will be required for initial starting. There is no possibility of lasting damage to the heater occurring due to longer periods of non-use. If the limitations specified above are taken into account, a short combustion operation at regular intervals is not necessary.

IMPORTANT

The vehicle fuel tank should be at least $\frac{1}{4}$ full during each starting attempt. A tank fill level below $\frac{1}{4}$ of the maximum filling capacity can result in the formation of bubbles and then false starts and smoking.

3.5 Switching off/Switch-off function

The auxiliary heater is switched off together with the engine. The additional heater switches itself off via the programmed heating time or is switched off with the respective heater control. The combustion is ended and the run-on begins. In the process, the combustion air fan continues to run to cool down the heater, the metering pump is switched off and the solenoid valve is closed so that the flame extinguishes. Restarting is not possible until the run-on has been completed.

NOTE

The run-on time and the combustion-air fan speed are dependent on the heater model and operating mode from which the heater is switched off.

Switch-off or new switch-on signals are processed according to the following rules:

1. A switch-off signal on a heater control always as priority irrespective of the heater operating state.
2. If the original switch-on signal is no longer active, or if the included heating duration has expired, then this is interpreted as a switch-off signal.
3. New switch-on signals are ignored until the original switch-on signal is no longer active.
4. It is therefore not possible to change the heating time during operation. The heater must be switched off and then on again with the changed heating duration.
5. If the heater has been started as an auxiliary heater, then switching off the vehicle engine must be interpreted as a switch-off signal (legal requirement).
6. A restart of the heater is not possible until after the burn-out has completed and the first cooling phase (forced run-on) has been ended. New switch-on signals are temporarily stored and are not followed until then.

4 Technical data

Except where limit values are specified, the technical data listed in the tables refer to the usual heater tolerances of $\pm 10\%$ at an ambient temperature of $+ 20\text{ }^{\circ}\text{C}$ and at the rated voltage and in rated conditions. All electrical components are designed for a nominal voltage of 12 volts.

Heater	Operation	Thermo Top V Petrol	Thermo Top V Diesel
Type test permit	EMC heater	e1*72/245*2006/96*1232*__ e1*2001/56*2006/119*0018*__	
Model		Water heater with atomization burner	
Heat output	Full load Partial load	5.0 kW 3 kW	
Fuel		Petrol EN 228 DIN 51625	Diesel EN 590
Fuel consumption	Full load Partial load	0.67 l/h 0.39 l/h	0.60 l/h 0.35 l/h
Rated voltage		12 V	
Operating voltage range		10.5 to 16 V	
Nominal power consumption without circulating pump (without vehicle fan)	Full load Partial load	34 W 24 W	
Max. ambient temperature: Heater: - Operation - Storage		-40 to $+ 50\text{ }^{\circ}\text{C}$ -40 to $+ 120\text{ }^{\circ}\text{C}$	-40 to $+ 80\text{ }^{\circ}\text{C}$ -40 to $+ 120\text{ }^{\circ}\text{C}$
Perm. operating pressure (heat carrier)		0.4 to 2.5 bar	
Capacity of the heat exchanger		0.075 l	
Minimum capacity of the circuit		4.00 l	
Minimum flow rate for the heater		150 l/h	
CO ₂ in exhaust gas (permitted function range)		8 to 13.0 % by vol.	
Heater dimensions		Length 222 mm Width 91 mm Height 144/180 mm	
Weight		2.1 kg	

Fig. 401 Technical data for Thermo Top V

Circulating pump	4849	4847 Econ
Volume flow against 0.14 bar	500 l/h	450 l/h
Rated voltage	12 V	
Operating voltage range	9 to 16 V	
Rated power consumption	12 W	13.9 W
Dimensions, circulating pump	Length 107 mm Diameter 48.5 mm	Length 112 mm Diameter 48.5 mm
Weight	0.35 kg	0.285 kg

Fig. 402 Technical data for circulating pump

5 Troubleshooting

5.1 General error symptoms

NOTE

Before troubleshooting is conducted on the heater, an operating test should be carried out as described in section 6.2.

IMPORTANT

Troubleshooting work demands precise knowledge of the structure and theory of operation of the various components and must be carried out by trained personnel only. If in doubt, refer to section 2 or 3 for a description of how the functions interact.

IMPORTANT

The error remedy is generally limited to the localisation of the faulty components and provides information on defective line connections. The following potential sources of malfunctions are not directly detected by the heater and should always be checked so that they can then be excluded as the cause of the particular fault:

- Corrosion on connectors
- Contact fault on plug connections
- Crimping error on connectors
- Corroded cables and fuses
- Corroded battery terminals

Conduct a function test in the vehicle after rectifying each fault (see section 6.2)

Use only genuine spare parts!

If there is doubt as to whether the parts are reusable, then new parts should generally be installed.

5.1.1 Fault analysis on heater and components

Possible faults

Fault Description	Possible Faulty Component (see table in Fig. 502)
Heater does not react	1, 2, 3, 4, 16, 17
Heater does not heat	5, 6, 7, 8, 9, 10, 12, 15
Heater switches off prematurely	1, 5, 11, 12
Heater has intermittent combustion	5, 10, 12
Heater smokes in start-up phase	5, 8, 10, 12
Telestart cannot be tuned	1, 3, 4, 16
Vehicle passenger compartment is cold	4, 11, 13, 15
Heater smokes in heating phase/white smoke	5, 10, 12, 14
Heater smokes in run-on phase	5, 14
Fuel odour	8, 12

Fig. 501 Overview of possible faults

The overview only shows some of the possible faults. The Webasto Service Hotline must be contacted in individual cases.

Functional analysis of heater and its components

No.	System Component	Test/Measure/Parameter
1.	Power supply	Measure supply voltage under load at heater connector X2 ≥ 11.5 V, see section 5.2.2 (Undervoltage switch-off)
2.	Clock	Press Flame button; display lighting must light up Test W bus signal on Pin 2 on heater connector X1 with an LED lamp against "+" (LED flickers when button is pressed)
3.	Receiver (Telestart T80 and T91)	On 6-pin connector on receiver, test W bus signal on Pin 2 with an LED lamp against Pin 1 "+" (LED flickers when On button is pressed)
4.	Transmitter (Telestart)	Assign/teach transmitter as described in instructions for receiver Test operating mode on Telestart hand-held transmitter (heat/ventilate) Battery of hand-held transmitter should have sufficient capacity (new)
5.	Metering pump	Test continuity from connector X1, Pin 5 to connector X7 (blue) Test continuity from connector X7 (brown) against earth Test resistance of the metering pump at $+20$ °C = 5.2 ohms ± 5 % as described in section 8.6.2.2 Measure delivery rate with Webasto Thermo Test PC Diagnosis as described in section 8.6.2.2 - Petrol: 34 to 42 ml in 180 sec. at 7 Hz. - Diesel: 36 to 44 ml in 180 sec. at 7 Hz. Test connection of fuel line on connection piece as described in section 8.6.2.1
6.	Glow plug	Measure glow plug resistance value on glow plug connector X3 (white wire) as described in section 6.3.1.4. At 24 ± 6 °C: 0.200 to 0.300 ohms.
7.	Fuel preheating	Test resistance of fuel preheating on connector X6, 4-pin (black wire) as described in section 6.3.1.2 for Variant 1 or 2
8.	Solenoid valve (if present)	Testing of solenoid valve as described in section 6.3.1.3. At 20 ± 5 °C: 145 ± 9 ohms.
9.	Temperature sensor	Test sensors as described in section 6.3.1.5 Coolant temperature sensor G1, blue wire, at 20 ± 6 °C: min. 1,988, max. 4,050 ohms. Overheating sensor G2: Red wire, at 20 ± 6 °C: max. 250 ohms.
10.	Combustion air fan	Test operation of fan motor with Webasto Thermo Test PC Diagnosis component test Checking of CO ₂ setting as described in section 6.2.2
11.	Circulating pump	Test resistance and installation as described in section 8.6.1: 10 ± 1 kohms Test operation with Webasto Thermo Test PC Diagnosis component test
12.	Fuel connection	Fuel visible in line? Air Bubbles in fuel line? If there is, then change connection or routing of line! Check connection in vehicle fuel system (also see section 8.6.2.1). Ensure sufficient fuel in vehicle tank (no reserve), fuel extraction installation correct, inspect fuel lines for leaks, kinks or clogging. Remove the heater and carry out troubleshooting in the workshop.

Fig. 502 Overview of functional analysis of heater and components

No.	System Component	Test/Measure/Parameter
13.	Coolant circuit	Test connection in vehicle coolant circuit as described in installation instructions/ installation suggestion, bleeding of coolant circuit ensured, test circulation in coolant circuit, eliminate kinks and chaffing.
14.	Exhaust system and air intake system	Intake pipe and exhaust pipe routed as described in installation instructions/installation suggestion Make sure lines are not restricted with insulation/clogged Eliminate existing leaks on intake pipe and exhaust pipe (now CO ₂ in intake air)
15.	Vehicle fan	Test switching signal on relay K3 (Pin 86) as described in installation instructions/ installation suggestion Watch coolant temperature (K3 switches at 50 °C) Test flap position of vehicle heater (air conditioning set to HI)
16.	Control unit/heater locked	Unlock as described in section 5.2.2 and installation instructions/installation suggestion
17.	Control unit (fault memory)	Read out fault memory with Webasto Thermo Test PC Diagnosis, then print out and clear fault memory. Include fault log when sending heater to Webasto.

Fig. 502 Overview of functional analysis of heater and components

5.2 Faults

5.2.1 Fault lock-out due to fault on heater

If no flame forms, fuel will be delivered for a maximum of 240 seconds. Then the heater goes into the fault mode and switches off. The reason for the fault may be faults described in section 5.1.1.

The fuel supply is shut off immediately if the system overheats (temperature limiter is tripped) and the heater goes into a heater lock-out.

In all cases (except for a defect in the combustion air fan), the fan is controlled after the fault lock-out to cool down the heater. Restarting is not possible until the run-on has been completed.

NOTE

Faults are not indicated by the heater control.

5.2.2 Fault lock-out due to undervoltage or overvoltage

At a battery voltage of less than approx. 11.5 V, a fault lock-out with a run-on is carried out. The minimum permissible voltage is customer-specific (software-dependent) and is measured at the wiring harness inlet.

In case of an overvoltage of 15 to 17 V (measured at the heater) for a certain period of time, a fault lock-out with run-on is also carried out.

Fault release

After the fault cause is eliminated, the fault release is carried out by switching the heater off and then on again.

Heater lock-out

In case of overheating, a heater lock-out will be initiated by the heater.

The heater release is carried out as described in section 3.3.

6 Operating tests

6.1 General

This section describes the tests of the heater and its components in the installed and the removed state.

WARNING

The heater must not be operated in enclosed areas such as garages and workshops without an emissions extraction system.

6.2 Operating checks in vehicle

6.2.1 Testing heating mode

- 1 Make sure that the vehicle fan speed is set to the slowest or to the speed recommended in the operating instructions.
- 2 Make sure that the air ducting to the heater is clear of foreign bodies (snow, leaves, etc.) and any pollen and dust filter are clear.
- 3 Make sure that the coolant circuit and the fuel system are carefully bled in accordance with the vehicle manufacturer's specifications.
- 4 Make sure that the fuel fill level is not at Reserve (1/4 fuel tank capacity) and the operating voltage is greater than 11.5 V.
- 5 Switch on the heater with the heater control or the Webasto Thermo Test PC Diagnosis.
- 6 When the heater is switched on, the circulating pump and the combustion air fan run (perceptible by listening). The vehicle fan runs when the coolant temperature has reached approx. 40 °C to 50 °C.
- 7 The heater then starts after approx. 130 sec. This can be detected from exhaust exiting at the exhaust silencer or connection piece.
- 8 Allow the heater to run. Check the heating effect at the air outlet of the vehicle fan.

NOTE

The heating effect is dependent on several factors: To evaluate it, the outside temperature, the vehicle model, the engine temperature and the type of integration in the vehicle cooling system, the quantity of coolant to be heated up and the time since the start must be used for the evaluation.

- 9 Switch off the heater again with the heater control or the Webasto Thermo Test PC Diagnosis.

- The run-on is activated with the heater is switched off. This is apparent from the fact that exhaust stops exiting and the circulating pump continues to run (perceptible by listening).
- Then the heater is switched off completely (with the auxiliary heater, with the ignition switched off).

6.2.2 Setting CO₂ content

The heater is optimally set to a CO₂ value for operation at altitudes between 0 and 1,000 m above sea level at the factory. Continuous operation above 1,000 m above sea level can result in heavy smoking and soot formation and in failure of the unit.

IMPORTANT

After replacing the fan unit or the control unit, the CO₂ value must be reset in full-load combustion operation!

NOTE

The CO₂ value of the exhaust gas must be measured only after the heater has operated in full-load combustion for approx. 8 min. Measure the CO₂ approx. 20 mm from the end of the exhaust outlet using a CO₂ meter (e.g. from MSI).

The CO₂ setting is carried out with Webasto Thermo Test PC Diagnosis.

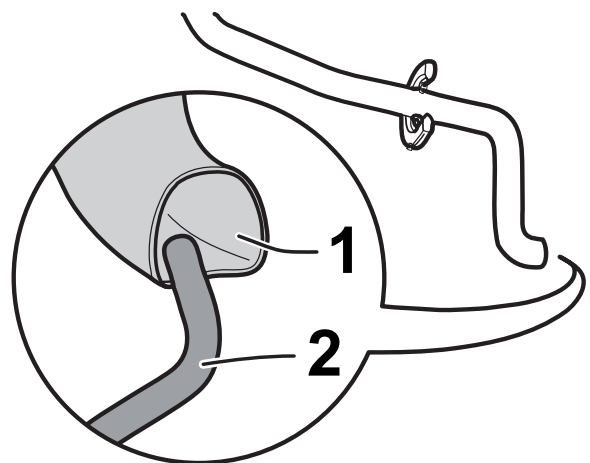

Fig. 601 CO₂ setting

NOTE

The hose -2- of the exhaust probe may not hinder the exhaust from exiting the exhaust pipe -1- during the test.

The following table shows the nominal CO₂ setting value in full-load combustion operation in dependence on the geodetic altitude at which the setting is made.

Altitude [m above sea level]	Nominal CO ₂ setting value at 10 ± 10 °C ambient temperature [% by vol.]
0	10
200	10.2
400	10.5
600	10.8
800	11.1
1000	11.4

Fig. 602 CO₂ setting values

NOTE

It is recommended that the CO₂ value be set in accordance with the altitude of the location above sea level.

If the measured value is 0.8 % by vol. outside the setting value, check the air intake and exhaust system for clogging or constrictions in the cross section and the delivery rate of the metering pump (see section 8.6.2.2).

6.3 Operating test in workshop

6.3.1 Testing individual components

6.3.1.1 Testing fan unit

The fan must be tested with the Webasto Thermo Test PC Diagnosis V 2.08 (or higher) as follows:

Connect the control unit to the Webasto Thermo Test PC Diagnosis and the operating voltage connector. Select the component test for the fan motor and operate the motor at 255 % for at least 60 sec. Testing of current consumption and running noises.

A diagnosis setting of 255 % is equivalent to 100 % output of the fan motor.

Current consumption at 255 % and 12 V operating voltage: max. 3.8 A

No rubbing noises may be heard.

NOTE

The current consumption cannot be read off in the diagnosis and must be measured separately with an adapter cable between the voltage source and the control unit input. To check the current consumption and running noises, the fan need not necessarily be removed from the heater.

6.3.1.2 Testing fuel preheating

When testing the cold resistance, a distinction must be made between Variant 1 heaters without a solenoid valve and Variant 2 heaters with a solenoid valve. Also see section 2.2.1.

For this purpose, the contacts 3 and 4 of connector X6 (see Fig. 701) of the fuel preheating is connected to a multimeter and the resistance measured.

In addition, it must also be ensured that the contacts 3 and 4 have no short-circuit to earth with the metal housing of the burner.

Variant	min. cold resistance [ohms] at 24 ± 6 °C	max. cold resistance [ohms] at 24 ± 6 °C
1	2,679	3,522
2	0,757	0,967

Fig. 603 Resistance values for fuel preheating

NOTE

When measuring the cold resistance, the fuel preheating must have cooled down to room temperature.

6.3.1.3 Testing solenoid valve

Only for diesel burners with solenoid valve.

Testing cold resistance:

Connect the contacts 1 and 2 of connector X6 (see Fig. 701) from the solenoid valve to a multimeter and measure the resistance.

Cold resistance at 20 ± 5 °C: 145 ± 9 ohms.

Testing opening state:

Pump fuel via Webasto Thermo Test PC Diagnosis. The valve is to open when a voltage of 12 V is connected. In the deenergised state, the valve is closed so that no fuel can enter the combustion chamber.

6.3.1.4 Electrical test of glow plug

The cold resistance must be checked using a multimeter with the 4-conductor measuring principle. Multimeters without the 4-conductor measuring principle may not be used for this purpose.

Cold resistance between Contact 1 and 2 (connector X3, see Fig. 701) at $24 \pm 6 \text{ }^\circ\text{C}$: 0.200 to 0.300 ohms.

Short-circuit test between Contact 1 or 2 (connector X3, see Fig. 701) and fan housing = ∞ ohms

6.3.1.5 Testing temperature sensor and overheating sensor

When testing the cold resistance, a distinction must be made between the variants coolant temperature sensor G1 (NTC) and overheating sensor G2 (PTC). For this purpose, the contacts of the connector X5 (see Fig. 701) of the sensors are connected to a multimeter and the resistance measured.

In addition, the short-circuit to earth to the metal housing, wire crimpings and deformations of the plastic cap of the sensors must also be checked.

Variant	Contacts on connector X5	min. cold resistance [ohms] at $20 \pm 6 \text{ }^\circ\text{C}$	max. cold resistance [ohms] at $20 \pm 6 \text{ }^\circ\text{C}$
G1 (NTC)	Connect Contact 2 to 6	1998	4050
G2(PTC)	Connect Contact 3 to 7	0	250

Fig. 604 Resistance values of temperature sensor and overheating sensor

7 Circuit diagrams

7.1 General

Fig. 701 shows the plug assignment on the control unit.

Fig. 702 shows the circuit of the Thermo Top V heater, additional heater and 12 V digital timer.

See section 7.2 for legend of wiring diagram.

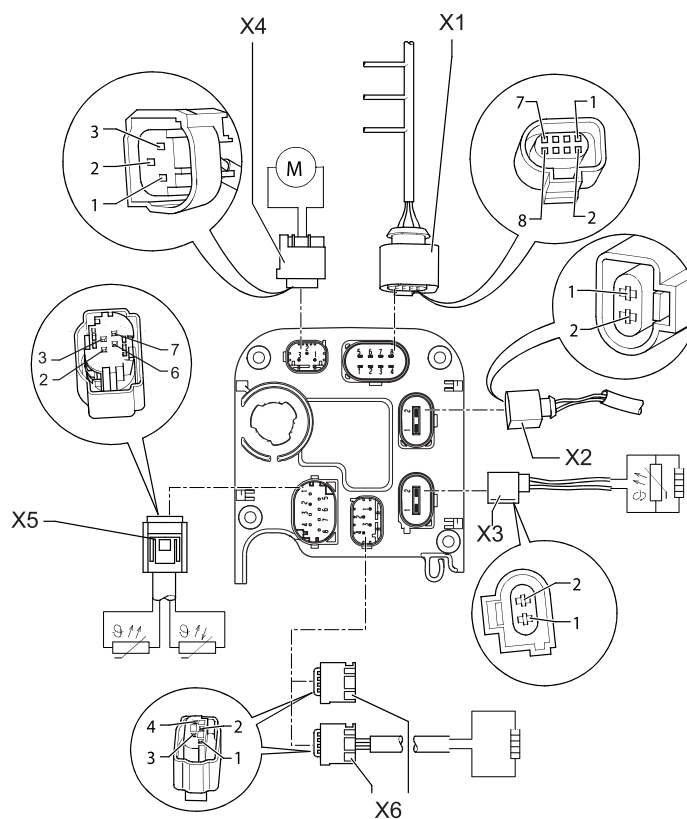

X1 = Connection of vehicle wiring harness (radio remote control, control of metering pump)

X2 = Connection of 2x power supply to vehicle
 - Contact 1: Power supply of Terminal 30 (fuse)
 - Contact 2: Earth connection

X3 = Connection to glow plug

X4 = Connection to circulating pump

X5 = Connection to heater temperature sensors

X6 = Connection to fuel preheating/solenoid valve

Fig. 701 Connector assignment of heater

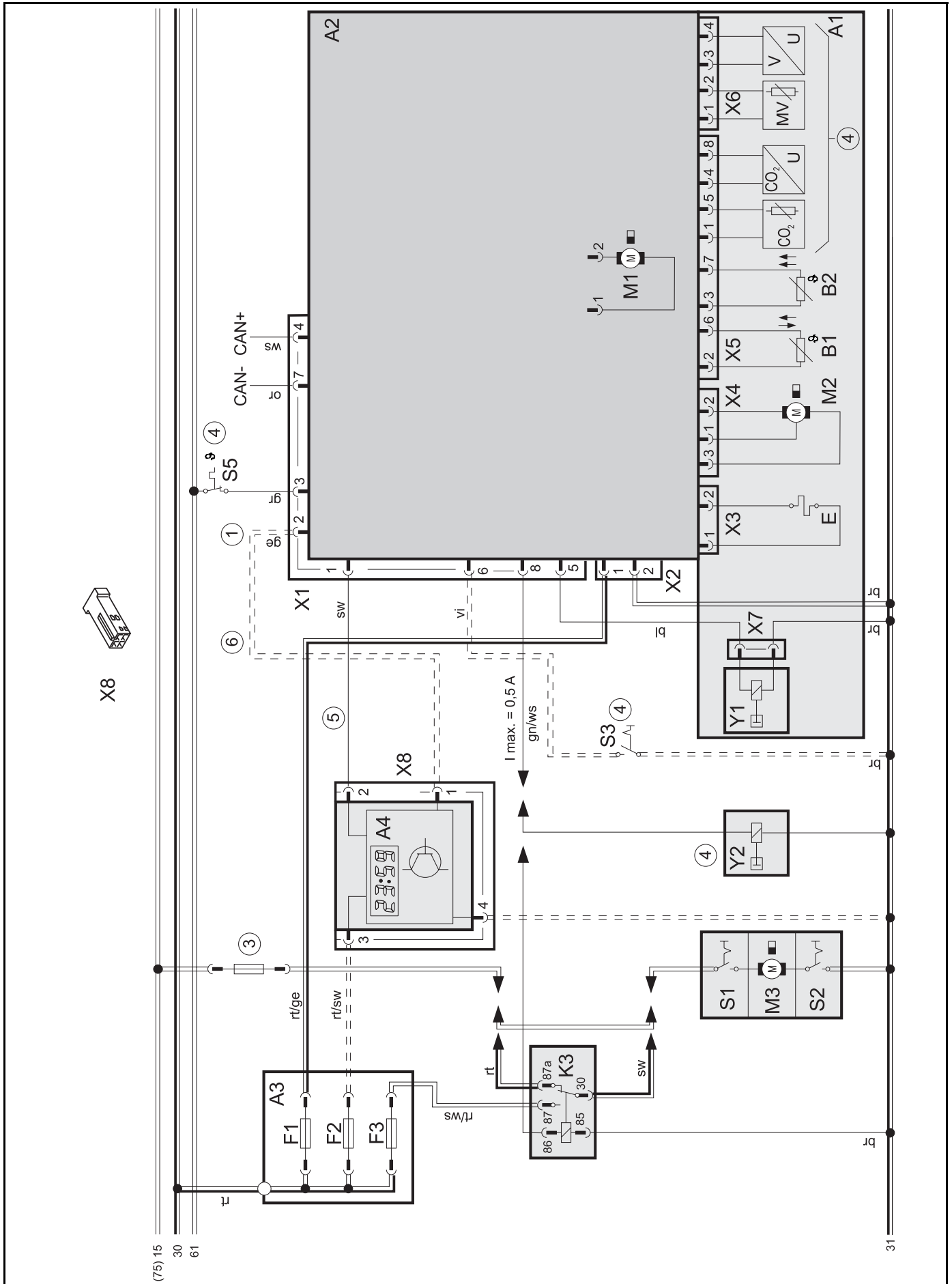

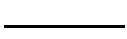
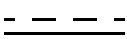

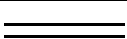
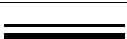

Fig. 702 Wiring diagram of Thermo Top V additional heater and 12 V digital timer.

7.2 Legend for wiring diagram

Cable cross-sections		
	< 7.5 m	7.5 - 15 m
	0.5 mm ²	0.75 mm ²
	0.75 mm ²	1.0 mm ²
	1.0 mm ²	1.5 mm ²
	1.5 mm ²	2.5 mm ²
	2.5 mm ²	4.0 mm ²
	4.0 mm ²	6.0 mm ²

Cable colours	
bl	blue
br	brown
ge	yellow
gn	green
gr	grey
or	orange
rt	red
sw	black
vi	violet
ws	white

Item	Description	Comment
①	Webasto data bus interface	W bus
②	Webasto outside temperature	
③	Vehicle fan fuse	present in vehicle
④	Option	
⑤	Main switch	
⑥	Summer/winter operation via W bus	
A1	Heater	Thermo Top V
A2	Control module	
<u>A2</u>	Fuse holder	
<u>A4</u>	Digital timer	with W bus
<u>B1</u>	Temperature sensor	
B2	Overheating sensor	
E	Glow plug	
F1	Fuse 20 A	Flat fuse SAE J 1284
F2	Fuse 1 A	Flat fuse SAE J 1284
F4	Fuse 25 A	Flat fuse SAE J 1284
K3	Relay	Vehicle fan
M1	Motor	Combustion air fan
M2	Motor	Circulating pump
M3	Motor	Vehicle fan
S1	Switch for vehicle fan	S1 or S2 depending on vehicle
S2	Switch for vehicle fan	S1 or S2 depending on vehicle
S3	Switch	Summer/winter switch
S4	Switch	Coolant
S5	Sensor (optional)	Outside temperature
X1	Plug connector, 8-pin	
X2	Plug connector, 2-pin	
X3	Plug connector, 2-pin	
X4	Plug connector, 3-pin	
X5	Plug connector, 8-pin	
X6	Plug connector, 4-pin	
X7	Plug connector, 2-pin	
X8	Plug connector, 4-pin	
Y1	Metering pump	
Y2	Solenoid valve	

8 Servicing work

8.1 General

This section describes the servicing work that can be carried out on the heater when it is installed.

WARNING

There is a danger of burns, as the heater and the attached parts may be extremely hot.

8.2 Work on the heater

Disconnect the 20 A fuse for voltage interruption of the heater or the main power cable from the vehicle's battery before carrying out any work on the heater. The main battery power must not be disconnected whilst the heater is operating or slowing down as a result of the risk of the heater overheating and the overheating protection thus being tripped. If extensive repair work is carried out on the heater, it must be completely removed. After work is performed on the heating circuit, a coolant mixture of water and antifreeze must be added in accordance with the vehicle manufacturer's specifications and the heating circuit must be carefully bled.

8.3 Work on the vehicle

WARNING

A temperature of 120 °C must not be exceeded in the vicinity of the heater under any circumstances (for example, during painting work on the vehicle).

8.4 Heater trial

The heater must not be operated in enclosed areas such as garages and workshops without an emissions extraction system, even if you use the timer.

8.5 Servicing work

The following servicing work is to be carried out once a year to maintain the functional reliability of the heater:

- Visual inspection of the heater for external damage, fastening and, if possible, external cleaning (avoid penetration of water)
- Inspect electrical connections for contact corrosion and firm seating and examine wiring routing (for cracks, kinks or rub spots)
- Check the exhaust and combustion air lines for signs of damage and to ensure that they are clear
- Check fuel lines for leaks (cracks, kinks or rub spots)
- Check coolant hoses and circulating pump (if present) for leaks (cracks, kinks or rub spots)

- Check fastening of circulating pump and metering pump for damage
- Conduct operating test of heater as described in section 6.2.

8.6 Visual inspections and installation instructions

8.6.1 Connection to vehicle cooling system

The circulating pump should preferably be integrated in the direction of flow upstream of the heater and deep enough in the coolant circuit so that automatic bleeding of the circulating pump is ensured. The circulating pump must be secured on the vehicle.

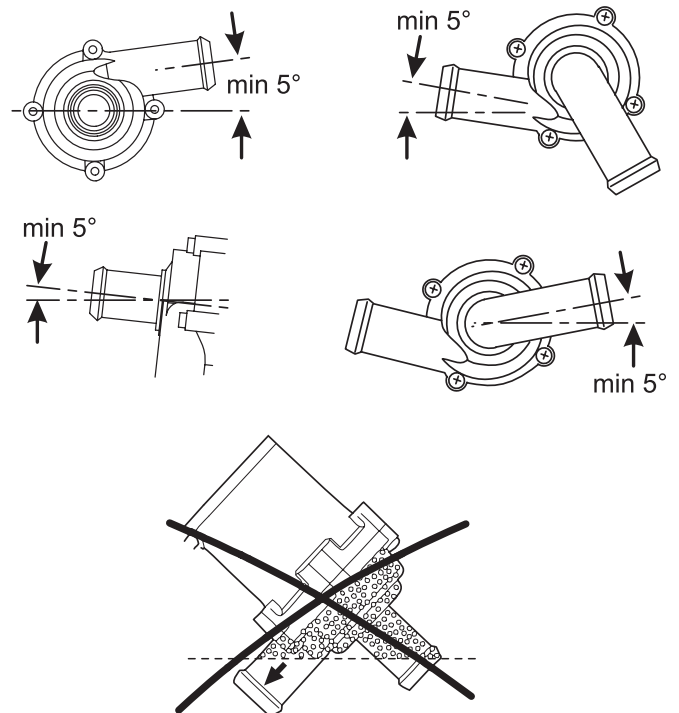

Fig. 801 Circulating pump U4849 and U4847 ECON installation positions

NOTE

The pump can only bleed automatically if at least 1 connection piece opening is at least 5° over the horizontal plane.

WARNING

The correct direction of flow of the heater must be ensured!

NOTE

A defective circulating pump must be replaced with the U4847 ECON in accordance with the spare parts list.

Electrical checking of circulating pump

Internal resistance of the circulating pump: 10 ± 1 kohms

In addition, the operation of the pump must be tested as follows:

When starting the heater, a slight vibration must be felt on the pump. When controlling with the Webasto Thermo Test PC Diagnosis with maximum power, a soft pump noise must be audible.

8.6.2 Connection to vehicle fuel system

The values for the maximum pressure at the fuel extraction point are listed in following table.

Permissible fuel inflow height H [m]	At max. perm. pressure [bar] in the fuel line	
	Petrol	Diesel
0.00	DP40: 0.30 DP41: 0.10	DP40: 2.00 DP41: 0.10
1.00	DP40: 0.22 DP41: 0.02	DP40: 1.92 DP41: 0.02
Permissible fuel intake height S [m]	At max. perm. negative pressure [bar] in the fuel tank	
	Petrol	Diesel
0.00	-0.1	-0.1
0.50	-0.06	-0.06
1.00	-0.02	-0.02

	Petrol	Diesel
Pressure line length	0 to 6 m	2 to 4 m
Inside hose diameter	2 ± 0.2 mm	2 ± 0.2 mm

NOTE

An empty fuel line or larger bubbles in the fuel line or metering pump can result in a repeat start of the heater with increased smoke.

8.6.2.1 Fuel lines

IMPORTANT

The hose connections on the connection pieces from the heater, the metering pump, fuel standpipe and various hose connection pieces must be executed as shown in Fig. 802. Mecanyl lines must mounted flush up to the connection pieces to prevent collections of bubbles.

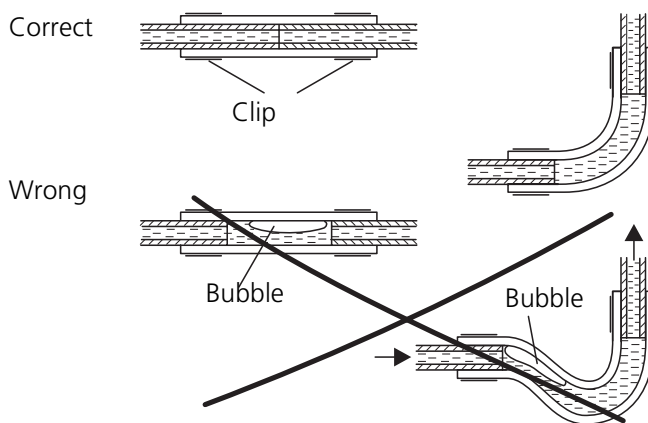

Fig. 802 Pipe/hose connections

8.6.2.2 Metering pump

It is advisable to install the metering pump in a cool place to avoid the formation of bubbles during operation. The maximum ambient temperature must not exceed $+20$ °C at any time during operation.

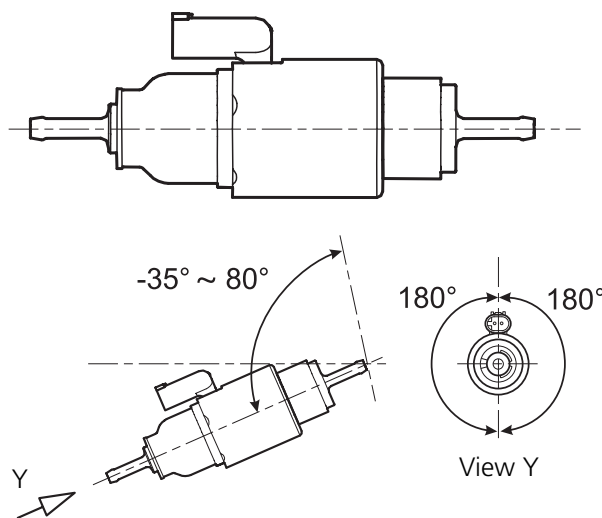

Fig. 803 Installation position of DP40/DP41 metering pump

For the diesel heater with a solenoid valve, the DP41 (ID No. 9009529_) is used without a zero termination, as a pressure compensation must be carried out between the closed solenoid valve in the heater and the tank (= fuel removal point).

Overview of uses for metering pumps

Metering pump	Use
DP41 ID No. 9009529_	Diesel heater with solenoid valve (see section 2.2.2)
DP40 ID No. 9002853_	– Diesel heater without solenoid valve – Petrol heater

IMPORTANT

Observe DP41 information sign (do not use for petrol)!

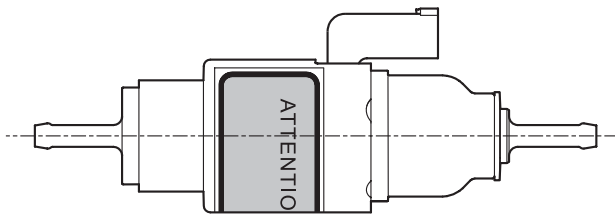

Fig. 804 Information sign of DP40/DP41 metering pump

IMPORTANT

The **DP40 (ID No. 9002853_)** may not be used for the heater **with solenoid fuel valve**, as otherwise fuel may escape!

The **DP41 (ID No. 9009529_)** may not be used for heaters **without solenoid fuel valve** or for **petrol heaters**, as otherwise fuel may escape.

WARNING

The use of the DP2 and DP30 is prohibited for the Thermo Top V heaters.

Delivery quantity of metering pumps DP40 and DP41

Modulation frequency of metering pump [Hz]	Diesel	Petrol
1	115 ml/h	109 ml/h
5.24 (full load for diesel)	603 ml/h	-
6.14 (full load for petrol)	-	669 ml/h
7 (testing of delivery quantity with PC diagnosis)	40 ml in 180 sec.	38 ml in 180 sec.

Tolerance of the delivery quantity: $\pm 10\%$ depending on the ambient conditions and the application.

Operating temperature

Pumping medium	DP41 ID No. 9009529_	DP40 ID No. 9002853_
Arctic Diesel	-40 to +30 °C	-40 to -10 °C
Winter diesel	-20 to +30 °C	-20 to +30 °C
Winter petrol	not approved	-40 to +10 °C
Summer petrol	not approved	0 to +20 °C

WARNING

The metering pump and fuel lines must not be installed within range of the radiated heat from hot vehicle parts. If necessary, a thermal radiation guard must be provided in order not to exceed the maximum permissible operating temperature.

NOTE

The metering pump requires a correct body earthing point for operation. If faults occur in other wires in the vehicle, a potential offset of the earthing point can occur. If the vehicle earthing point is not 0 V, but is instead $> +0.25$ V, then the heater may be supplied with an insufficient quantity of fuel.

Electrical checking of metering pump

Resistance of metering pump at +20 °C: 5.2 ohms $\pm 5\%$

8.7 Heater, removal and installation

8.7.1 Removal

- 1 Interrupt power supply of heater by removing 20 A blade fuse from Webasto fuse holder.
- 2 Separate connectors on heater.
- 3 Open coolant cap, release pressure and close cap again.
- 4 Loosen hose clamps and pull coolant hoses off heater.
- 5 Disconnect exhaust pipe from heater or detach fasteners of exhaust system.
- 6 Remove heater from bracket or detach bracket with heater from vehicle.
- 7 Loosen hose clamps, pull off fuel line and seal off with suitable sealing plugs etc.

NOTE

All open plugs and connectors must be protected against moisture and soiling.

NOTE

The coolant must be prevented from escaping with hose clamping pliers or caught with appropriate containers.

8.7.2 Installation

- 1 Move heater into position and fasten on bracket.
- 2 Connect fuel line and fasten with hose clamp.
- 3 Connect coolant hoses and fasten with spring clips.
- 4 Fasten exhaust pipe on heater.
- 5 Restore all electrical connections on plug connector.
- 6 Connect vehicle battery.
- 7 Bleed coolant circuit.
- 8 Bleed fuel system if necessary.

WARNING

Only the original-equipment wiring harness approved by Webasto may be used.

IMPORTANT

A polarity reversal of the power supply can result in damage to the control unit. The correct polarity of the connection wires must be ensured. A direct connection to a power supply without an intermediate fuse is not permissible.

8.8 Initial start-up

After the heater has been installed, the coolant circuit and the fuel supply system must be carefully bled. Observe the vehicle manufacturer's specifications when doing so.

All coolant and fuel connections must be checked for leaks and secure attachment during a trial run of the heater. If the heater suffers a fault during operation, troubleshooting must be carried out (see Chapter 5).

9 Repair

9.1 General

This section describes the permissible repair work on the Thermo Top V heater while removed. If it is dismantled further, any and all warranty claims are voided. An operating test must be conducted after all repairs.

9.2 Dismantling and assembling

9.2.1 Dismantling heater

1. Loosen screw (1, Fig. 901) and remove water connection piece unit (A) with O-rings (B).
2. Loosen screw (4) and remove exhaust connection piece (J) from heat exchanger (H). This work step is eliminated with a fixed exhaust connection piece.
3. Loosen heater cover (C) at 4 side detents on fan housing (T) with a screwdriver. Then remove heater cover (C) from heater toward front.
4. Remove cable cover (S) from fan housing (T).
5. Press air-intake connection piece (O) slightly to side and pull out of control unit (Q) in axial direction.
6. Release connector cover (P) on side facing away from fuel connection piece at side detents with a screwdriver and take off heater.
7. Loosen detent of connector (K, L, M) and pull connector off control unit (Q).
8. Loosen screws (3) and pull heat exchanger (H) off fan housing (T) in axial direction of screw fitting.
9. For information on removing the burner (D), see section 9.2.5.
10. For information on removing temperature sensor and overheating sensor (G), see section 9.2.8.

Only steps 1, 2, 3, 4, 5 and 6 are necessary to replace the temperature sensor and overheating sensor!

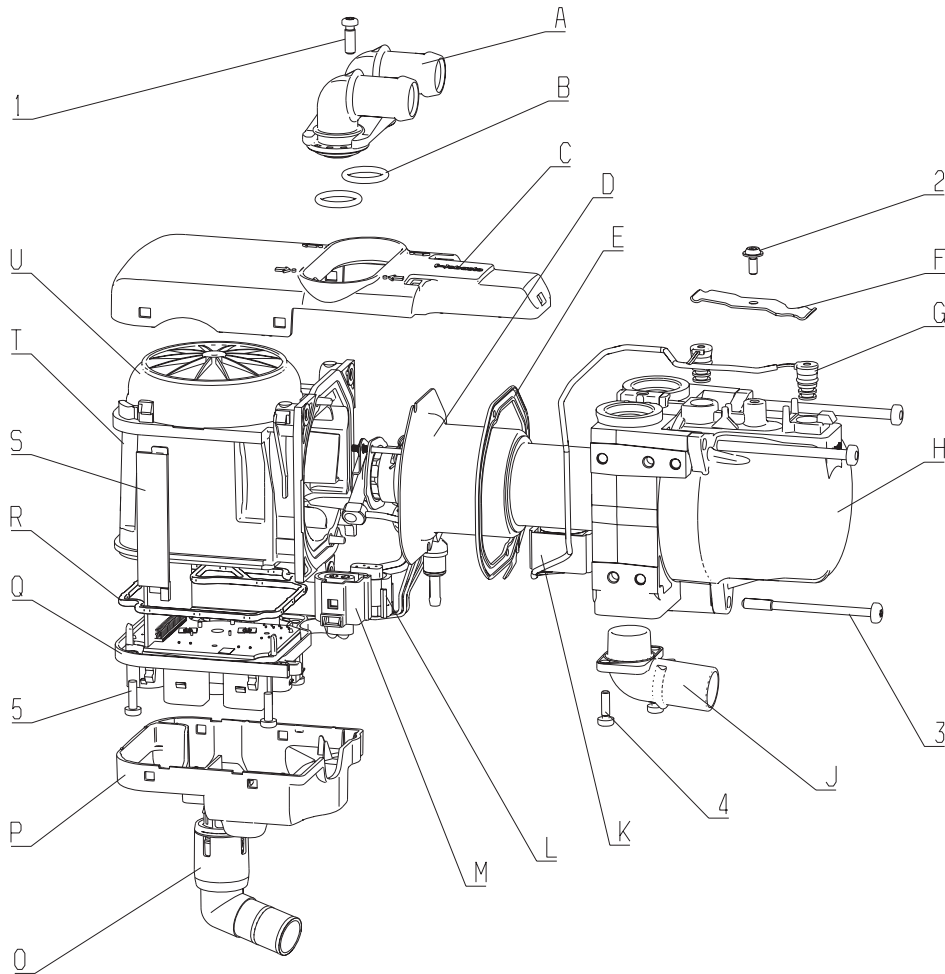

Fig. 901 Dismantling heater

9.2.2 Assembling heater

1. For information on installing new temperature sensors (G, Fig. 901), see section 9.2.9.
2. For information on installing burner (D), see section 9.2.7.
3. Clean heat exchanger (H) inside and outside and place on fan. Tighten screws (3) with 7 ± 0.7 Nm and do not cut new thread if possible when doing so (i.e. turn screw into existing thread).
4. Insert connector (K, L, M) into control unit until it audibly engages. As the connectors are shape-coded, they can be neither confused nor incorrectly poled.
5. Place connector cover (P) on control unit (Q) and engage with light pressure.
6. Insert air-intake connection piece (O) into control unit (Q). In the process, the lug of the connection piece (O) must be guided into the opening provided (facing in direction of fuel connection piece). See Fig. 902.

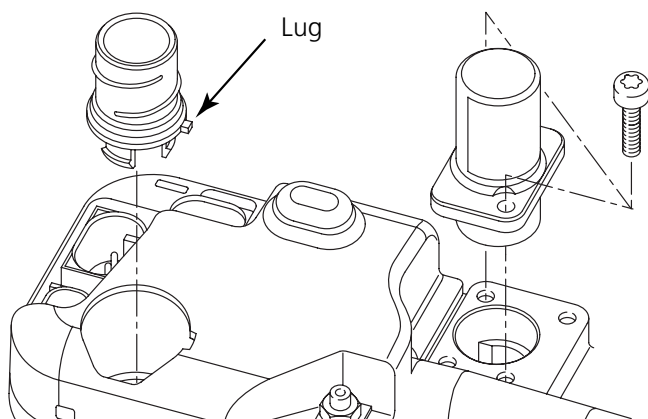

Fig. 902 Installing air-intake and exhaust connection piece

7. Hook heater cover at front into heater and engage in locking lug from fan housing (T).
8. Lay new O-rings (B) into heat exchanger (H) and fasten water connection-piece unit (A) with screw (1) and do not cut a new thread when doing so (i.e. turn screw into existing thread). Tightening torque 7.5 ± 0.7 Nm.
9. Fasten exhaust connection piece (J) on heat exchanger (H) with screw (4). Tightening torque: 4.5 Nm
The work step is eliminated for the variant with a fixed exhaust connection piece.

IMPORTANT

When screwing on the water connection pieces and the sensors, do not recut the thread several times. The screw must be carefully screwed into the existing thread by hand and then tightened with the specified torque.

IMPORTANT

Observe the different tightening torques for the screw fitting of the water connection piece with teeth (4.5 Nm) and without teeth (7.5 Nm)!

9.2.3 Installing water connection piece variants

9.2.3.1 Installing water connection-piece variant A with teeth

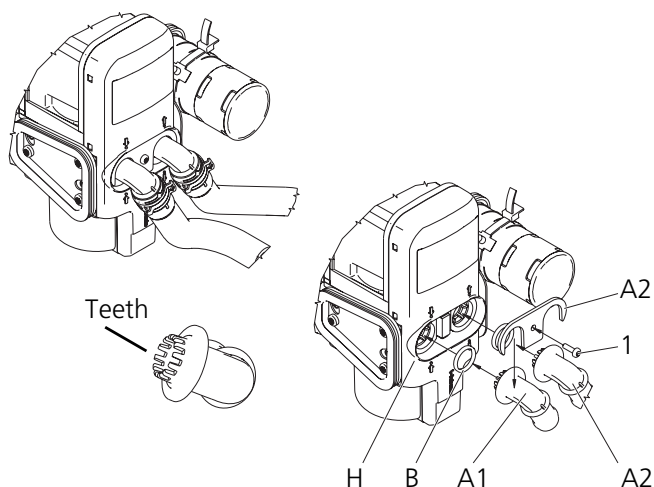

Fig. 903 Installing water connection-piece variant A with teeth

Assemble heater as described in section 9.2.2 up to point 7. and then install water connection piece as follows:

1. Moisten new O-rings (B, Fig. 903) with coolant and lay in heat exchanger (H).
2. Insert water connection pieces (A1) and (A2) with retaining plate (A3) in heat exchanger (H, Fig. 903).
3. Align water connection pieces in angle bracket in openings of heater transfer unit and guide into teeth with retaining plate (A3) and hold down.
4. Guide screw (1) into hole and screw on with 4.5 Nm. Connection piece and retaining plate must be held down while screwing on.

IMPORTANT

The O-rings and the openings of the heat exchanger must be sufficiently moistened with coolant. Without lubricant, the O-rings may be crushed, which results in leaks during operation.

9.2.3.2 Installing water connection-piece variant B without teeth

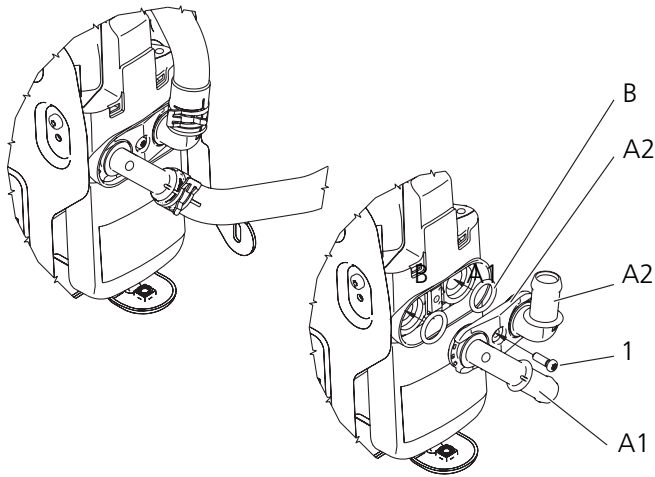

Fig. 904 Installing water connection-piece variant B without teeth

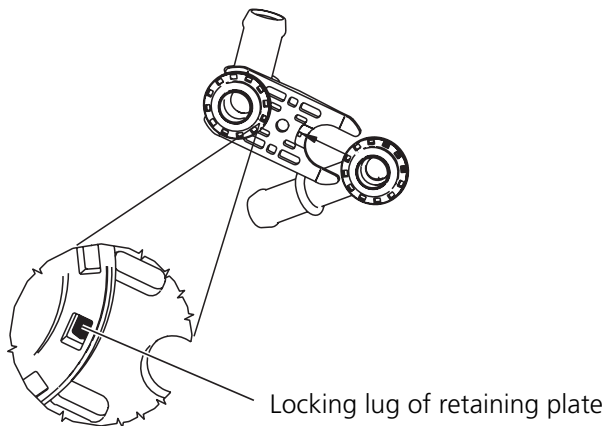

Fig. 905 Detail of lock on water connection-piece variant B without teeth

The water connection pieces must be engaged in the retaining plate before installing it in the heater. The locking lug must be engaged in the connection piece as shown. Engaging is carried out mechanically at Webasto, which is why the entire unit, consisting of the retaining plate and the connection piece, must always be ordered.

IMPORTANT

The locking lug must be engaged in the connection piece, as otherwise leaks and a loss of coolant can result. A later angle bracket adjustment is not permissible with the connection piece engaged.

1. Lay new O-rings (B) in the heat exchanger (H).
2. Insert water connection pieces (A1 and A2) with retaining plate (A3) as preassembled unit in heat exchanger (H).

3. Guide screw (1) into hole and screw on with 7.5 Nm.

9.2.4 Dismantling combustion-air fan unit

NOTE

It is not permissible to remove parts of the fan housing (T, Fig. 901)!

9.2.5 Removing burner

Dismantle heater as described in section 9.2.1 up to point 8. Pull off connectors (L and M, Fig. 906). Set down fan vertically with burner facing upward.

1. Remove seal (E) from fan housing.
2. Push grommet (TU) onto fuel pipe out of fan housing with slight pressure while lifting off burner in axial direction.

NOTE

The fuel pipe must not be bent when removing the burner.

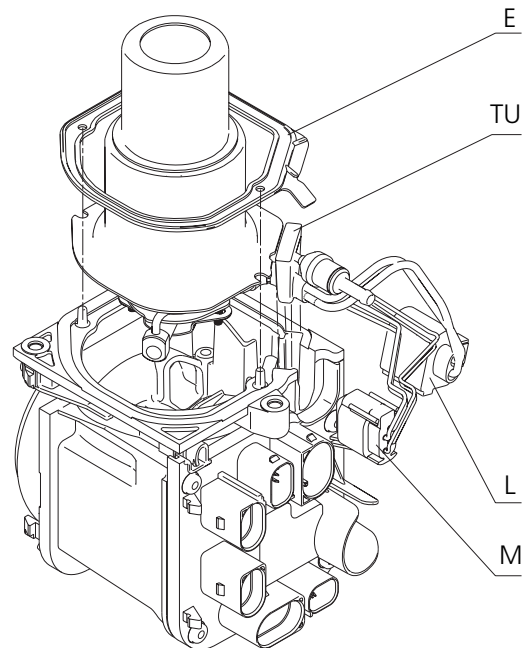

Fig. 906 Removing and installing burner

NOTE

Only for diesel burner with fuel preheating: the heating cartridge of the fuel preheating may not be removed!

NOTE

Only for diesel burners with solenoid valve: the solenoid valve cannot be removed!

9.2.6 Cable routing for glow plug on burner

Uninsulated wire end ferrules may not contact metal parts (A, Fig. 907)!

Route wire in direction of burner axis as shown (B, Fig. 908).

Align cable grommet parallel to outer edge of combustion pipe (C, Fig. 908).

IMPORTANT

Uninsulated areas of the glow plug cable must not touch and must not come into contact with metal parts of the burner or heater (danger of short circuits). The glow plug must not be radially loaded or jammed and must be screwed into the ceramic nozzle as far as possible during installation (danger of breakage).

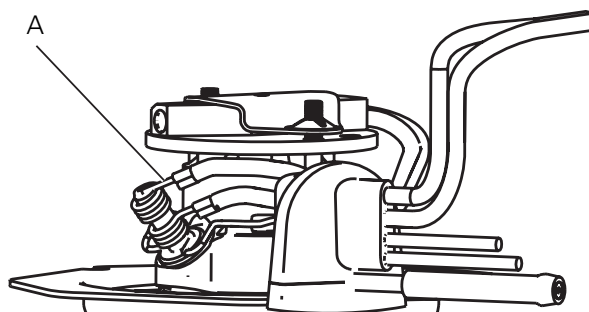

Fig. 907 Cable routing of glow plug

ID No. of burner

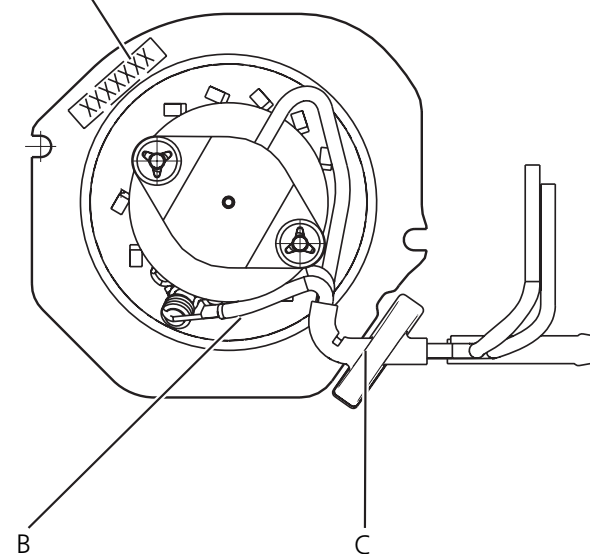

Fig. 908 Cable routing of glow plug

9.2.7 Installing burner

1. Preposition burner with grommet (TU, Fig. 906) in fan housing. Press grommet (TU) into groove provided until it completely fills out installation space.
2. Mount gasket (E) on positioning pins of fan housing with flat side facing fan.
3. Then continue as described in section 9.2.2 from point 3.

NOTE

When changing a burner, the correct model must be ensured (see section 2.2)! The assignment of the spare part burner must be carried out using the spare parts list via the ID number of the burner or the chassis number.

9.2.8 Removing temperature sensor and overheating sensor

IMPORTANT

The sensors can be damaged during removal. New sensors must always be used following removal!

The temperature sensor and the overheating sensor are inserted in the heat exchanger. The sealing O-ring can stick to the housing after some operating time, preventing its removal.

1. Remove plastic covers as described in section 9.2.1.
2. Pull connectors of sensors out of control unit. When doing so, make sure connector lock is released.

3. Loosen screw (2, Fig. 901).
4. Remove retaining spring (F) and pull sensors out of heat exchanger (sensors are not accessible from inside). Do not pull on plastic head or cable when doing so.

9.2.9 Installing temperature sensor and over-heating sensor

IMPORTANT

The sensors can be damaged during removal. New sensors must always be used following removal!

IMPORTANT

Incorrect wiring routing can result in heater malfunctions and/or coolant loss!

Cable routing with radially sealing water connection-piece variant A with teeth (section 9.2.3.1, with stainless-steel retaining plate):

See Fig. 910.

Cable routing with axially sealing water connection-piece variant B (section 9.2.3.1, with aluminium retaining plate):

See Fig. 911.

1. Moisten sensors with coolant and press as far as possible into hole of heat exchanger. In the process, ensure correct position of sensors and cable (see Fig. 910 and Fig. 911).
2. Lay on retaining spring and fasten with screw (2) with 4 ± 0.4 Nm tightening torque. Before screwing on, make sure that wires are not crushed by retaining spring as shown. Retaining spring (F) must face toward front with 2 side notches and be fixed in place by positioning pins of heat exchanger.
3. Route cable tautly as shown in Fig. 910 and Fig. 911. The cable may not lie outside the cable duct provided, as otherwise it may be damaged when installing the water connection piece.
4. The cable is then fixed in place in the control unit frame and the connector engaged in the connector basket.
5. Installing heater cover.
6. Installing connector cover and cable cover.

9.2.10 Heat exchanger

Existing soot deposits must be completely removed with a soft brass wire brush.

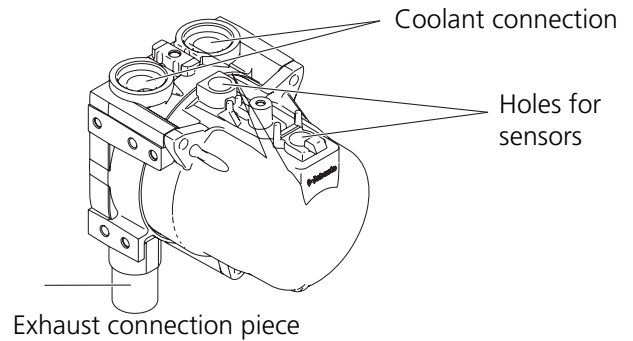

Fig. 909 Heat exchanger

IMPORTANT

The inside and outside section of the heat exchanger may not be removed!

NOTE

When changing the heat exchanger, only new sensors and new gaskets may be mounted.

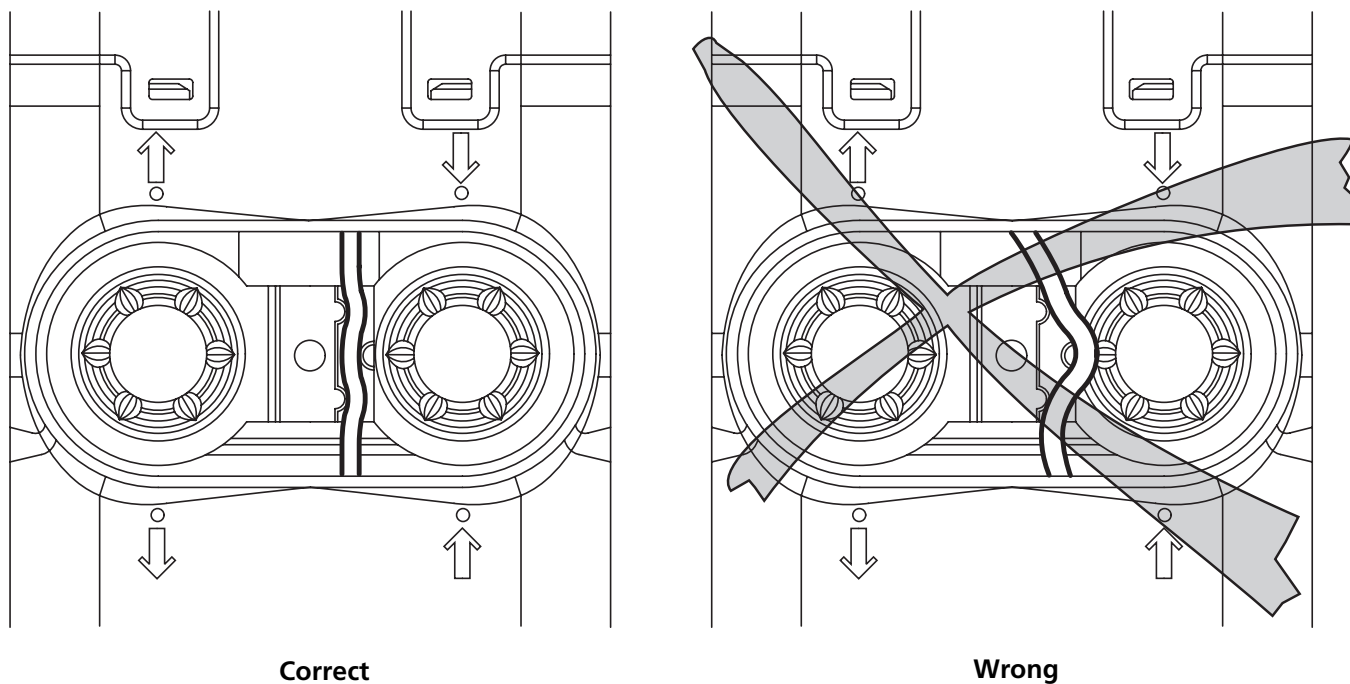

Fig. 910 Cable routing for temperature sensor and overheating sensor with water connection-piece variant A

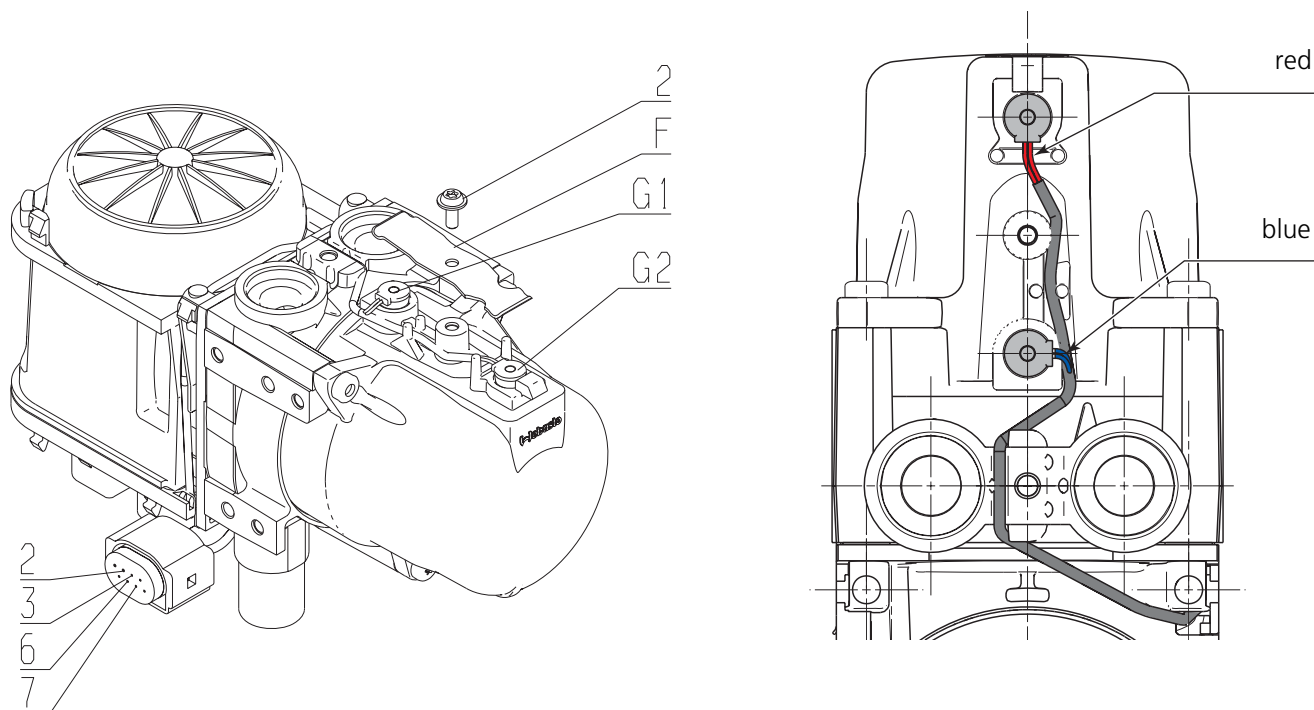

Fig. 911 Cable routing for temperature sensor and overheating sensor with water connection-piece variant B

10 Packing, Storage and Shipping

10.1 General

If the heater or its components are sent to Webasto AG for testing or repair, it must be cleaned and packed in such a way that it is protected against damage during handling, transport and storage.

10.2 Storage

Heater position

The heater can be stored in any positions. There are no restrictions here.

Heaters must always be stored in the delivery packaging or in similarly suitable packaging in closed rooms!

After being removed from the delivery packaging, the heaters should make contact only on the aluminium parts (for position, see Fig. 1001). The type label and the surface of the heater must be protected against damage with a suitable surface (e.g. cardboard).

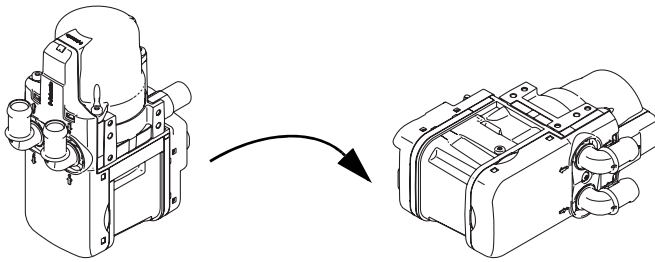

Fig. 1001 Preferred position of TT-V heater for storage and transport

The storage temperature should be at least -40 °C and a maximum of 60 °C .

During storage the heater should be covered and must be protected from dust, dirt and moisture.

The heater may not come into contact with chemicals or their vapours, e.g. fuel, battery fluids or brake fluids.

No dirt, water or chemicals may enter into the openings of the heater during storage (see above).

The fuel pipe must be protected from side impact loads which lead to pipe deformation

10.3 Transport

The heater can be transported in any position.

Heaters must always be transported in the delivery packaging or in similarly suitable packaging!

The electrical contacts must generally be protected against mechanical damage.

The temperature should be at least -40 °C and a maximum of 60 °C during transport.

The heater must be protected against environmental influences, such as rain, snow, stone impact, etc., during transport.

IMPORTANT

If an entire heater is returned, then it must be completely drained of operating fluids. It must be ensured that no fuel or coolant can escape during packing and/or shipping. The coolant connection piece and the fuel connection must be sealed off with blind plugs.

Webasto AG
Postfach 80
D - 82131 Stockdorf
Germany

National:
Hotline: 01805 93 22 78
(€ 0,14 aus dem deutschen Festnetz)
Hotfax: 0395 5592 353
Hotmail: hotline@webasto.de
www.webasto.de

International:
www.webasto.com