



WARNING: Do not smoke or carry lighted tobacco or open flame of any type when working on or near any fuel related components. Highly flammable vapors are always present and may ignite. Failure to follow these instructions may result in personal injury.



WARNING: This procedure involves fuel handling. Be prepared for fuel spillage at all times and always observe fuel handling precautions. Failure to follow these instructions may result in personal injury.



WARNING: Do not carry or operate cellular phones when working on or near any fuel related components. Highly flammable vapors are always present and may ignite. Failure to follow these instructions may result in personal injury.



WARNING: If fuel contacts the eyes, flush the eyes with cold water or eyewash solution and seek immediate medical attention.



WARNING: If taken internally, do not induce vomiting, seek immediate medical attention. Failure to follow these instructions may result in personal injury.



WARNING: Wash hands thoroughly after fuel handling, as prolonged contact may cause irritation. Should irritation develop, seek medical attention.



WARNING: The spilling of fuel is unavoidable during this operation. Make sure that all necessary precautions are taken to prevent fire and explosion.



CAUTION: Diesel fuel injection equipment is manufactured to very precise tolerances and fine clearances. It is therefore essential that absolute cleanliness is observed when working with these components. Always install blanking plugs to any open orifices or lines. Failure to follow this instruction may result in foreign matter ingress to the fuel injection system.



CAUTION: Make sure the workshop area in which the vehicle is being worked on is as clean and as dust free as possible. Foreign matter from work on clutches, brakes or from machining or welding operations can contaminate the fuel system and may result in later malfunction.

1.



WARNING: Do not work on or under a vehicle supported only by a jack. Always support the vehicle on safety stands.

Raise and support the vehicle.

2. Remove the transmission undershield.



Remove the 6 bolts.

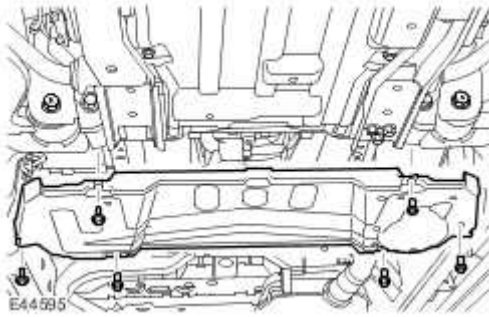

3.



WARNING: Observe due care when working near a hot exhaust system.

Remove the fuel filter heat shield.

- Remove the 3 bolts.

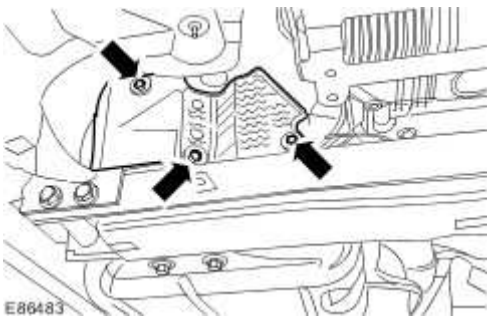

4. Drain the fuel filter element.

- Attach a suitable drain tube to the water-in-fuel drain port.
- Loosen the water-in-fuel drain port 2 complete turns and allow the fluid to drain into a container.
- Turn the ignition to position 2 until 100ml of fluid is drained, then turn to position O.
- Remove the drain tube.



5. Tighten the water-in-fuel drain port.

6. Install the fuel filter heat shield.

- Tighten the bolts to 6 Nm (4 lb.ft).

7. Install the transmission undershield.

- Tighten the bolts to 10 Nm (7 lb.ft).

