

(DT20C ENGINE)
JLR 3.0L 24V DOHC V6 TC Diesel

TYPE TIGHTENING TORQUES

1. Cylinder head

CAUTION : (*) Follow the tightening sequence.

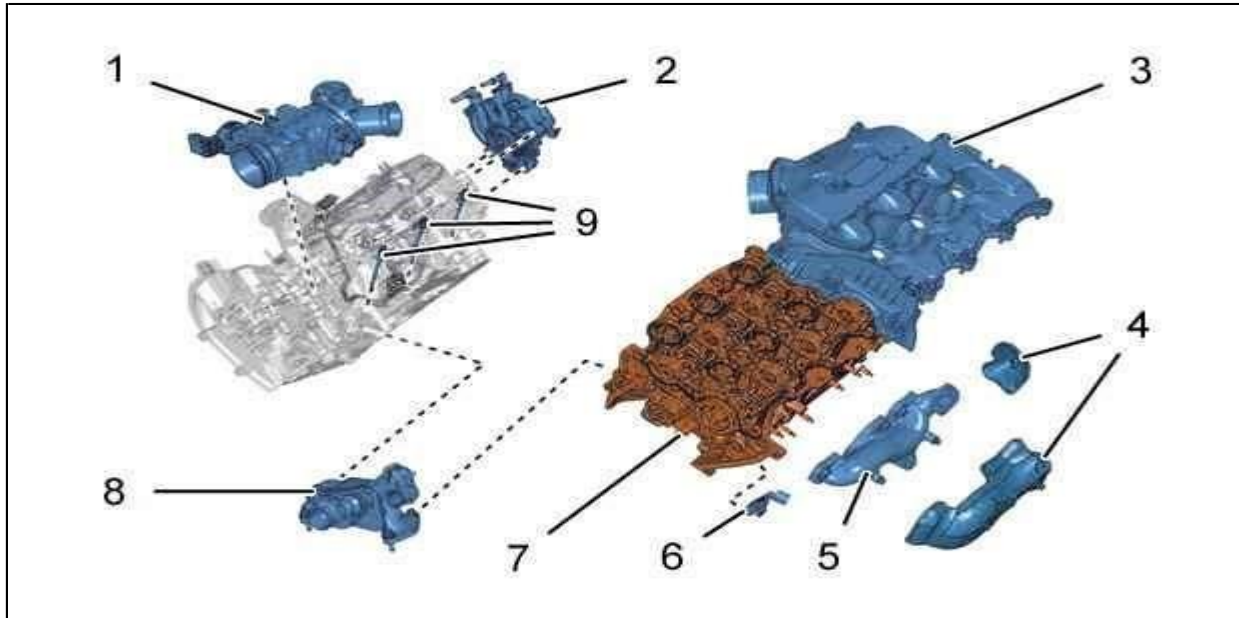

Reference	Designation	Tightening procedure
(1)	bolts - Throttle butterfly housing	Tightening torque to 9 Nm
(2)	bolts - vacuum pump	Tightening torque to 23 Nm
(3)	Inlet valve cover screws (*)	Tightening torque to 9 Nm
	Inlet valve cover studs (*)	
(4)	bolts - Exhaust manifold heat shields	Tightening torque to 10 Nm
(5)	studs - Exhaust manifolds	Tightening torque to 13 Nm
	nuts - Exhaust manifolds (*)	Tightening torque to 28 Nm
(6)	bolts - Cylinder reference sensor	Tightening torque to 9 Nm
(7)	studs - Exhaust manifolds	Tightening torque to 13 Nm
	Cylinder head bolts (*)	Pre-tighten to 20 Nm
		Tightening torque to 40 Nm
		Tightening torque to 80 Nm
	Angular tightening to 180°	
(8)	Coolant outlet housing	Tightening torque to 9 Nm
(9)	Pre-heater plugs	Tightening torque to 10 Nm

1.1. Order of tightening : bolts - studs (3)

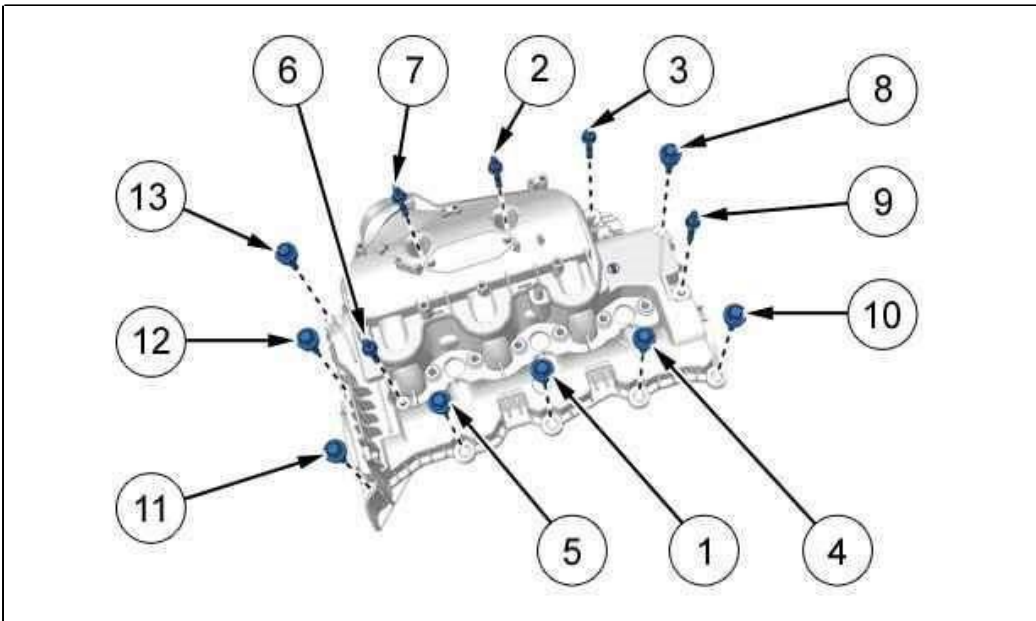
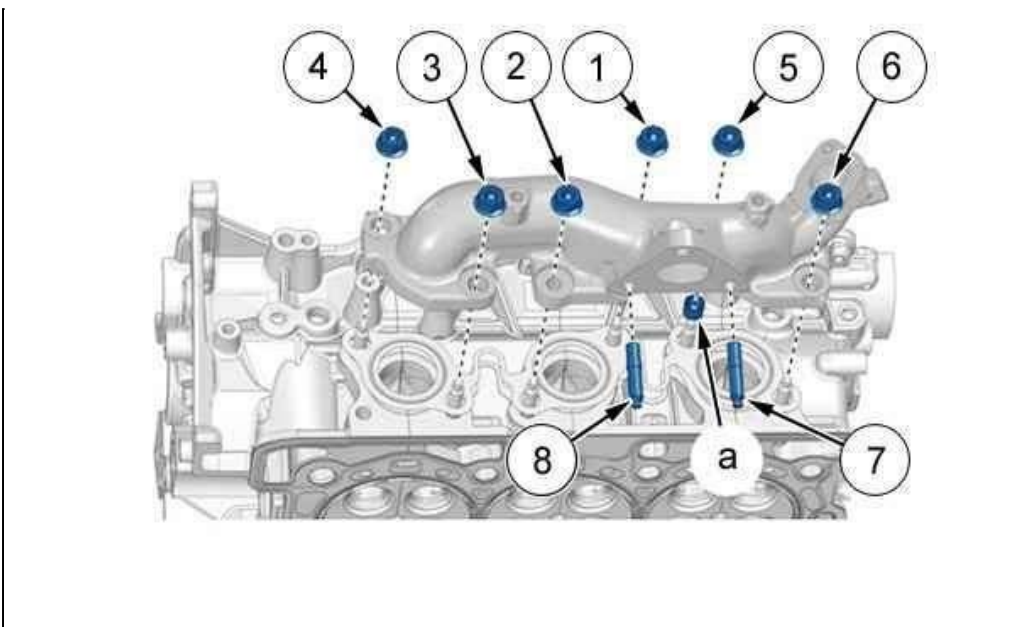

Figure : B1JB08HD

(3) Inlet valve cover screws.

(3) Inlet valve cover studs.

1.2. Order of tightening : nuts - studs (5)



(5) Exhaust manifold nuts.

(5) Exhaust manifold studs.

Tightening procedure : Exhaust manifold nuts :

1. Offer the exhaust manifold up to the cylinder head with the centering device "a"
2. Tighten the 6 nuts (5) to **28 Nm** (From 1 to 6)
Tighten the 2 studs (5) to **13 Nm** (From 7 to 8)

1.3. Sequence of tightening the bolts (7)

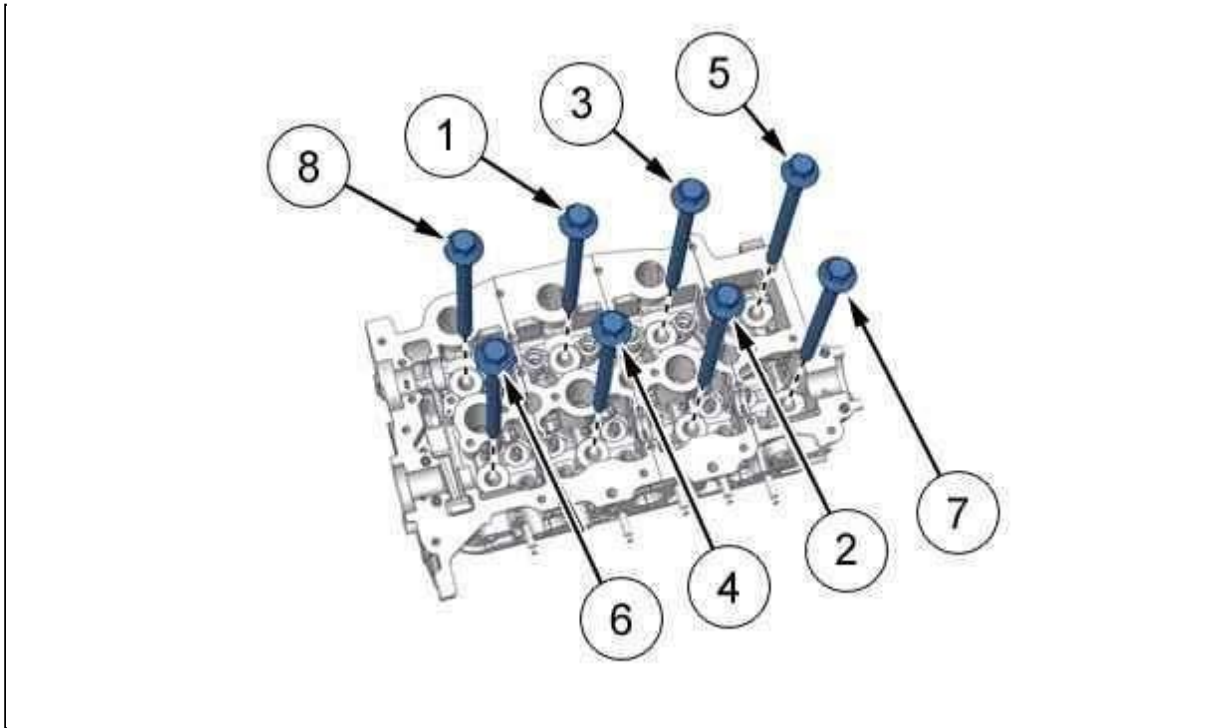

Tightening procedure : Cylinder head bolts :

1. Pre-tighten the 8 bolts (7) to **20 Nm** (From 1 to 8)
2. Tighten the 8 screws (7) to **40 Nm** (From 1 to 8)
3. Tighten the 8 screws (7) to **80 Nm** (From 1 to 8)
4. Angle tighten the 8 bolts (7) to 180° (From 1 to 8)

2. EGR (exhaust gas recycling) electro valve

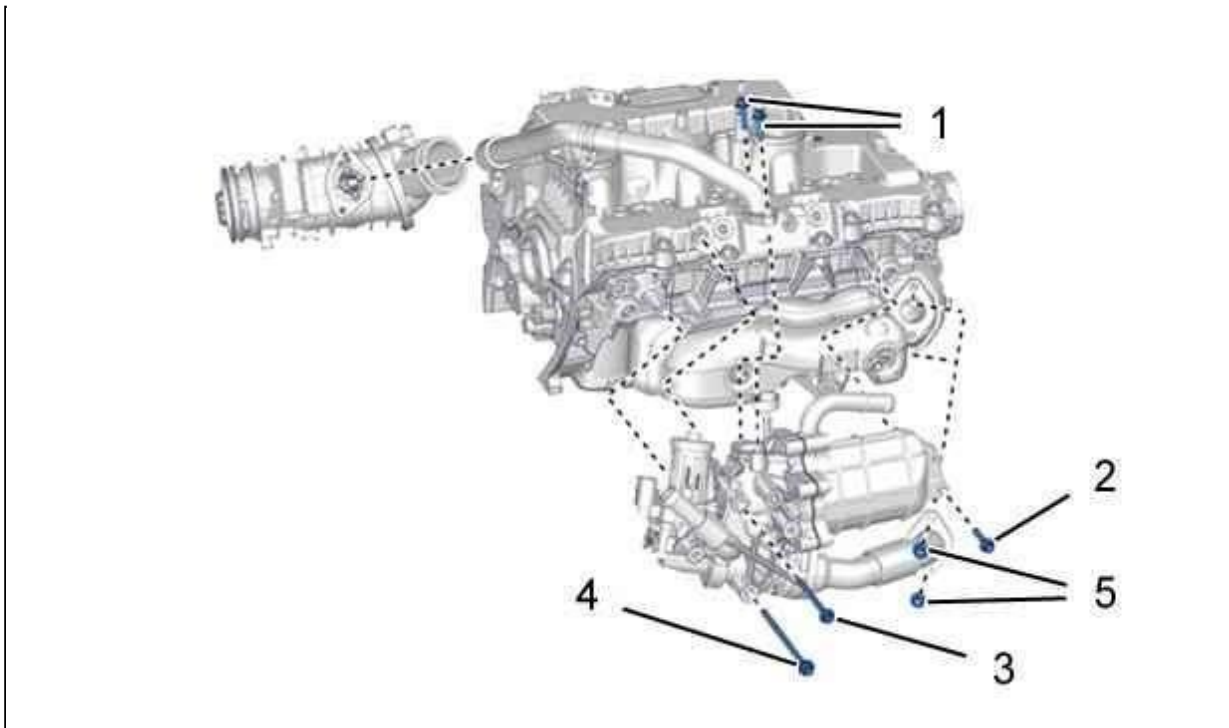

Figure : B1JB08JD

Reference	Designation	Tightening procedure
(1)	Output pipes from the exhaust gas recycling solenoid valve (E.G.R)	Tightening torque to 10 Nm
(2)	bolts M6x45 - Exhaust gas recycling solenoid valve (E.G.R) - Cylinder heads	Tightening torque to 10 Nm
(3)	bolts M6x80 - Exhaust gas recycling solenoid valve (E.G.R) - Cylinder heads	Tightening torque to 10 Nm
(4)	bolts M6x105 - Exhaust gas recycling solenoid valve (E.G.R) - Cylinder heads	Tightening torque to 10 Nm
(5)	bolts - Exhaust gas recycling solenoid valve (E.G.R) -Exhaust manifolds	Tightening torque to 10 Nm

5

3. turbocharger

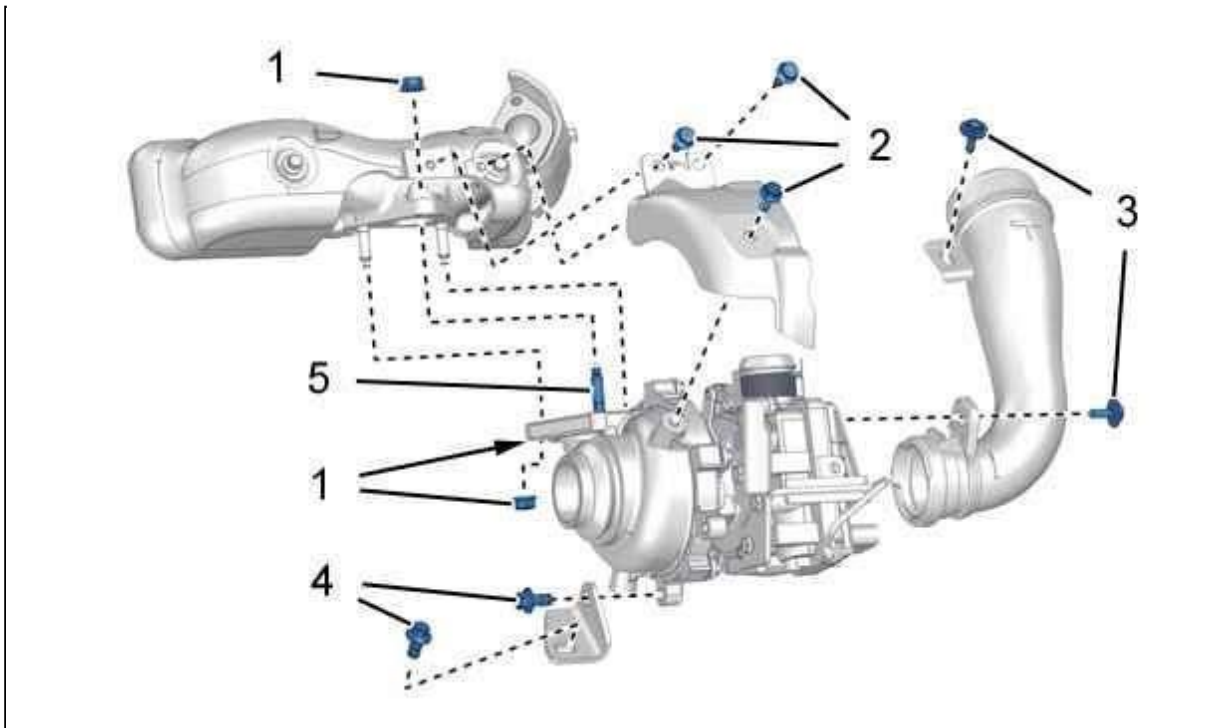
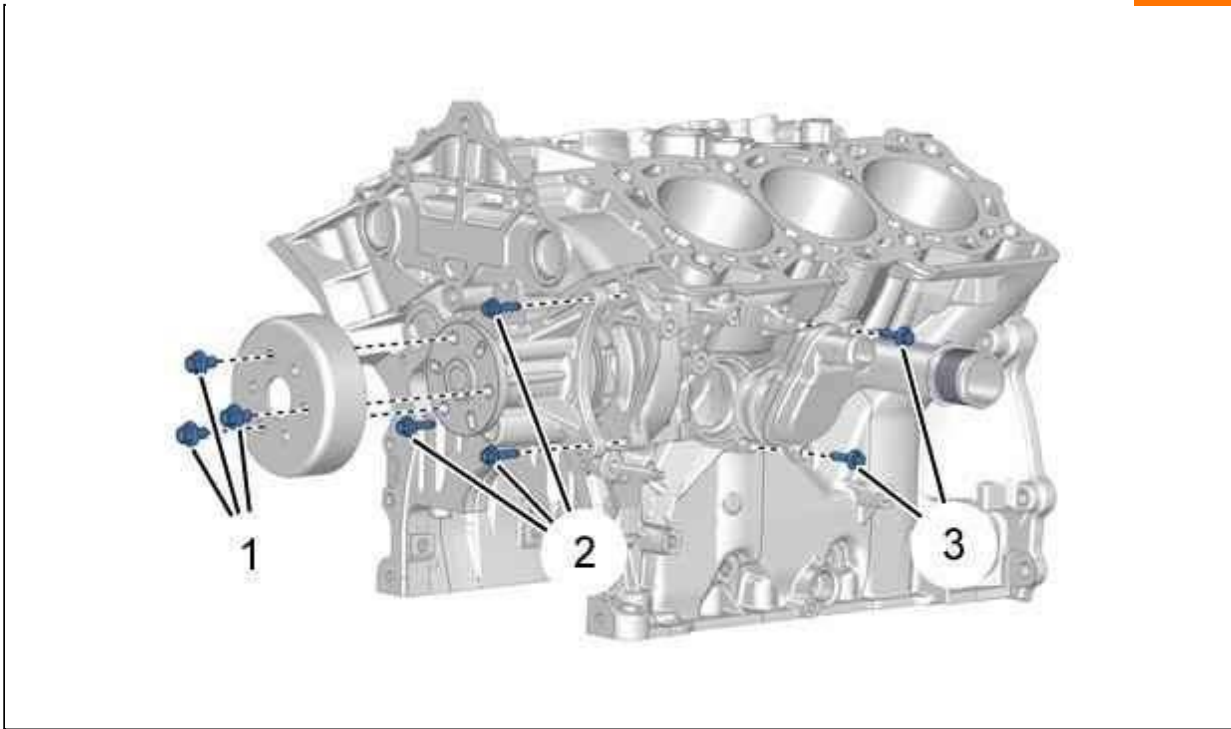

Figure : B1HB09RD

Reference	Designation	Tightening procedure
(1)	nuts - turbocharger	Tightening torque to 24 Nm
(2)	bolts - Turbocharger heat shields	Tightening torque to 9 Nm
(3)	bolts - Turbocharger air inlet union	Tightening torque to 9 Nm
(4)	bolts - Turbocharger connection mounting - Cylinder block (/)	Tightening torque to 33 Nm
(5)	studs - turbocharger	Tightening torque to 13 Nm



5. Cylinder block (7)

CAUTION : (*) Follow the tightening sequence.

Figure : B1CB00TD

Reference	Designation	Tightening procedure
(1)	bolts - Water pump pulley	Tightening torque to 25 Nm
(2)	bolts - Coolant pump	Tightening torque to 10 Nm
(3)	Water inlet housing	Tightening torque to 10 Nm

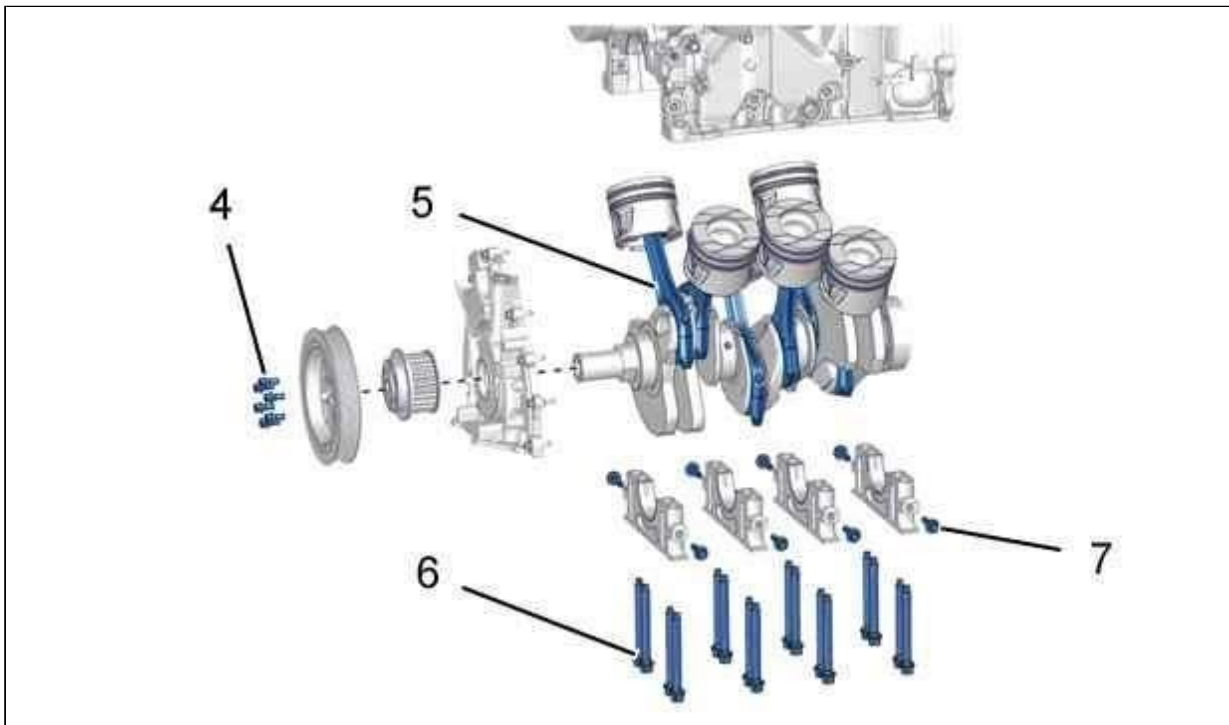

Reference	Designation	Tightening procedure
(4)	bolts - Accessories drive pulley	Tightening torque to 25 Nm
(5)	Conrod screws	Pre-tighten to 20 Nm
		Angular tightening to 90°
(6)	Crankshaft bearing caps fixing bolt (*)	Pre-tighten to 60 Nm
		Tightening torque to 145 Nm
		Angular tightening to 90°
(7)	bolts - Crankshaft main bearing cap casing (*)	Pre-tighten to 15 Nm
		Tightening torque to 33 Nm
		Angular tightening to 47°

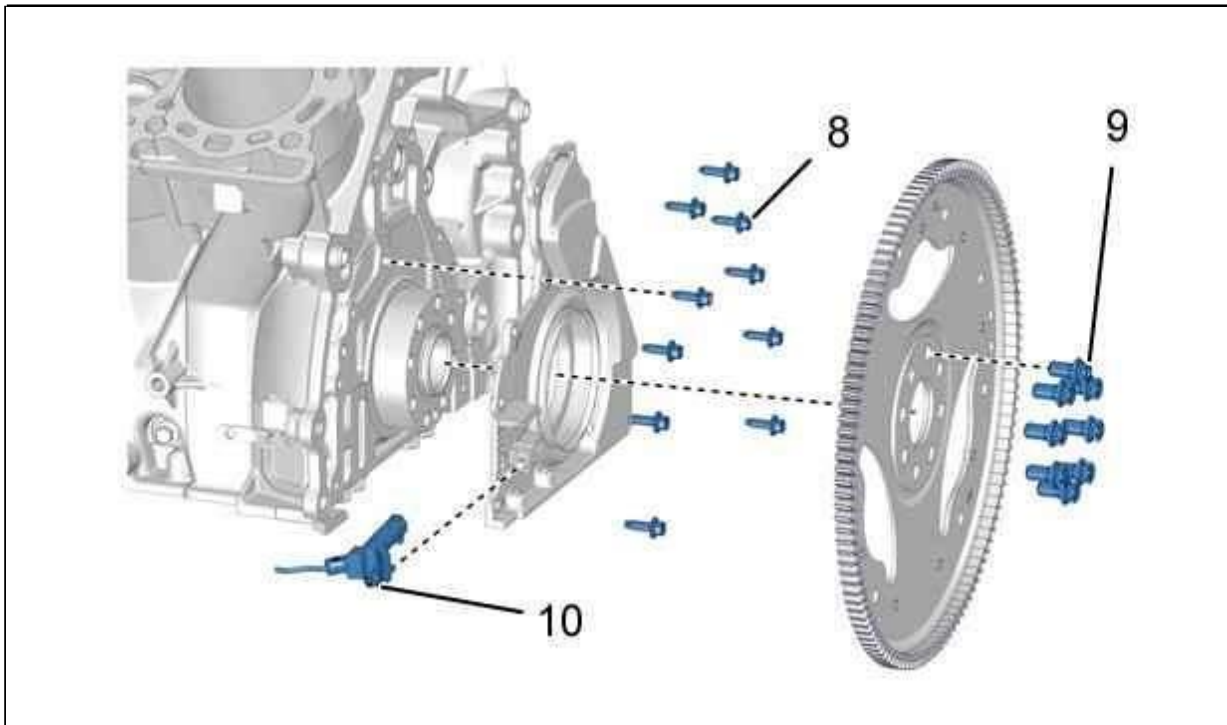

Figure : B1CB00UD

Reference	Designation	Tightening procedure
(8)	Closing plate fixing screws (Gearbox end) (*)	Tightening torque to 10 Nm
(9)	Bolts – Starter gearwheel carrier(*)	Pre-tighten to 50 Nm
		Angular tightening to 45°
		Angular tightening to 45°
(10)	Engine speed sensor	Tightening torque to 5 Nm

4.1. Sequence of tightening the bolts (6)

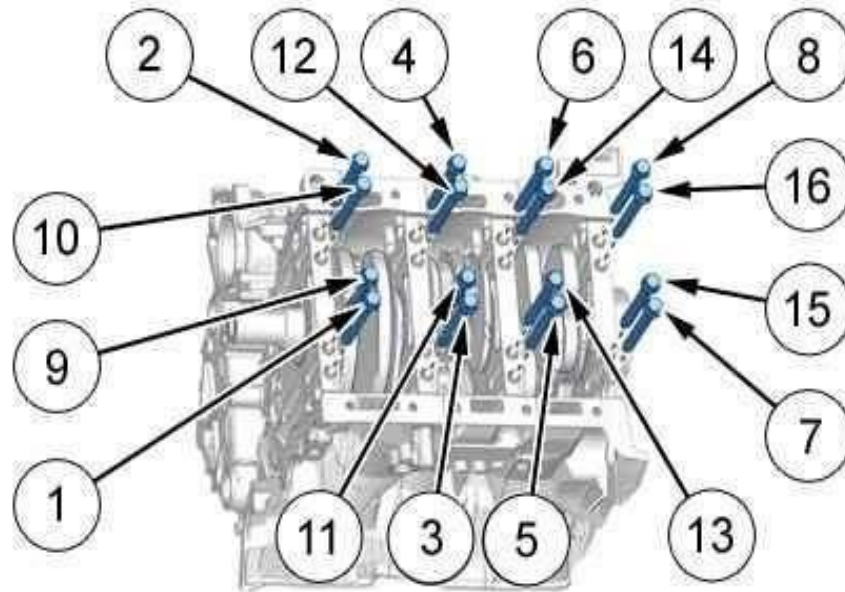

Figure : B1CB00VD

CAUTION : After each tightening check that the crankshaft turns freely in its bearings.

(6) Crankshaft bearing caps fixing bolt .

Tightening procedure : Crankshaft bearing cap bolts :

1. Pre-tighten the 16 bolts (6) to 60 Nm (From 1 to 16)
2. Tighten the 16 screws (6) to 145 Nm (From 1 to 16)
3. Angle tighten the 16 bolts (6) to 90° (From 1 to 16)

4.2. Sequence of tightening the bolts (7)

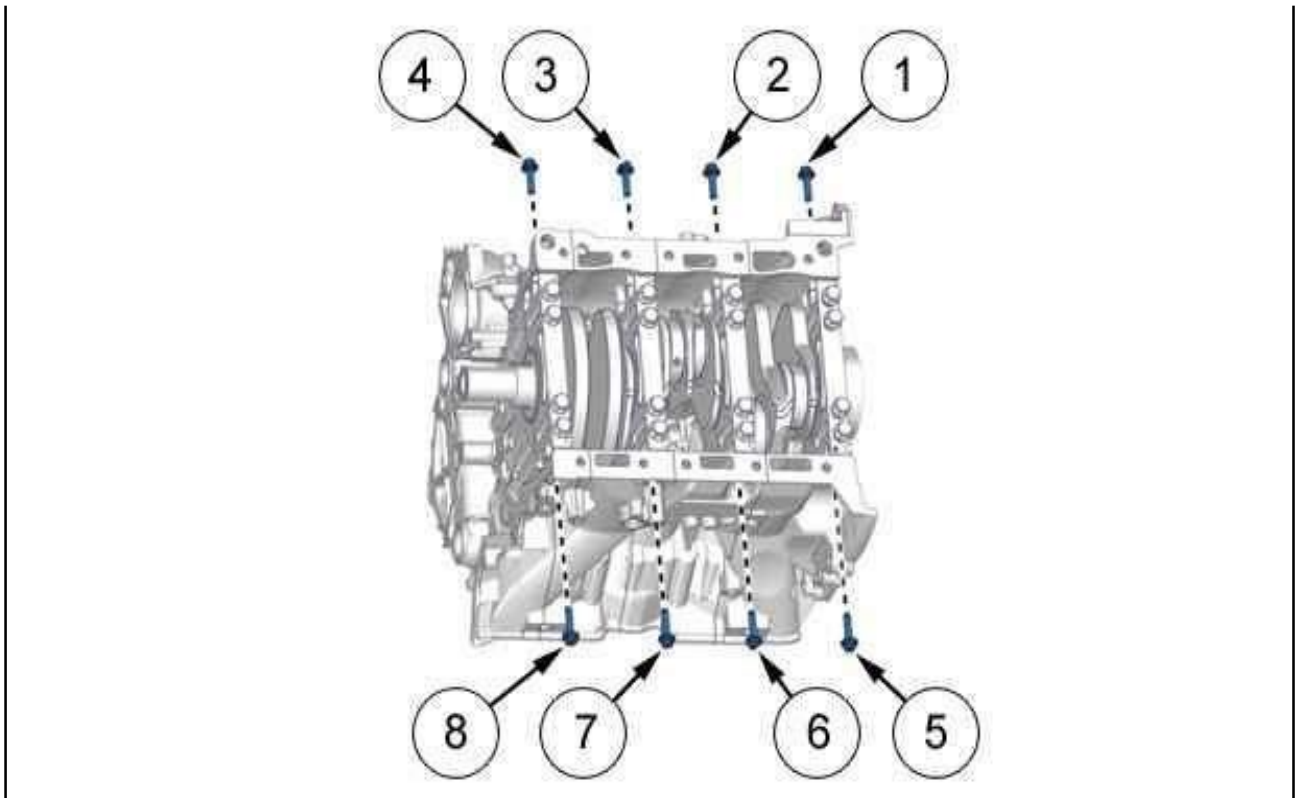

Figure : B1CB00WD

Crankshaft bearing cap housing fixing screws : Crankshaft bearing cap housing fixing screws :

1. Pre-tighten the 8 bolts (7) to 15 Nm (From 1 to 8)
2. Tighten the 8 screws (7) to 33 Nm (From 1 to 8)
3. Angle tighten the 8 bolts (7) to 47° (From 1 to 8)

4.4. Sequence of tightening the bolts (8)

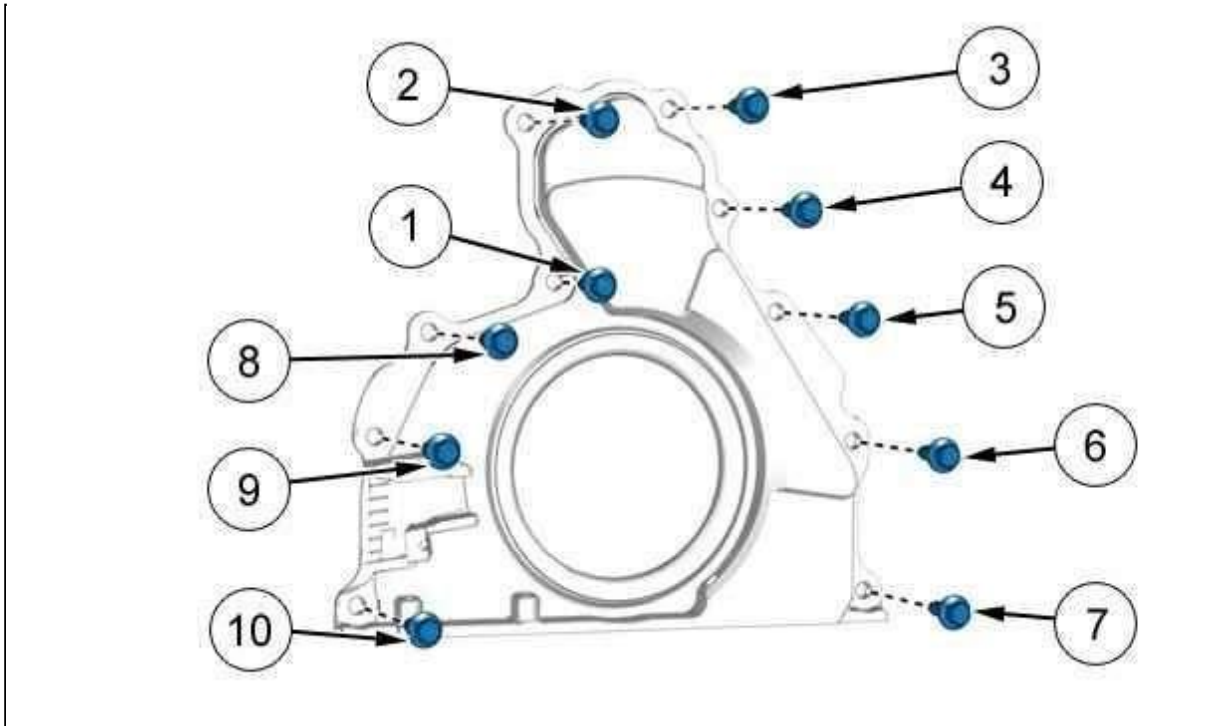

Figure : B1CB00XD

(8) Closing plate fixing screws (Gearbox end).

Tightening procedure : Closing plate (Gearbox end) :

1. Tighten the bolt (8) by hand (1)
2. Tighten the 9 bolts (8) by hand (From 2 to 10)
3. Tighten the 10 screws (8) to 10 Nm (From 1 to 10)

4.4. Sequence of tightening the bolts (9)

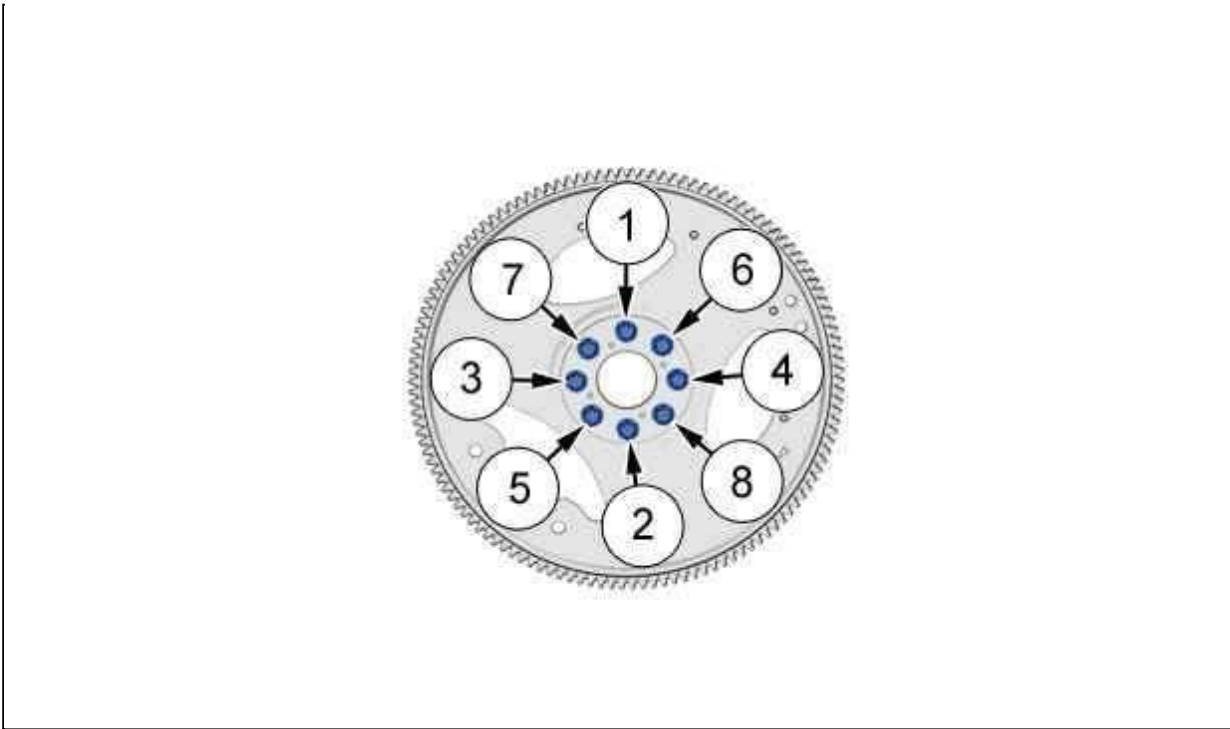

Figure : B1CB00YD

(9) Cap holder bolt of the starter motor.

Reference	Designation	Tightening procedure
(9)	Bolts – Starter gearwheel carrier(*)	Pre-tighten to 50 Nm
		Angular tightening to 45°
		Angular tightening to 45°

5. Lubrication

CAUTION : (*) Follow the tightening sequence.

DT20C Sump

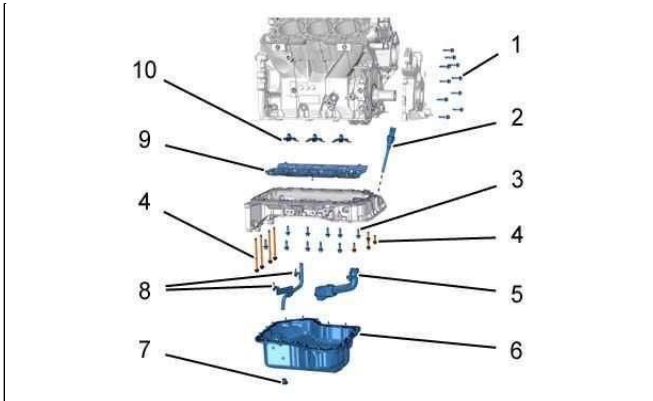

Land Rover Sump

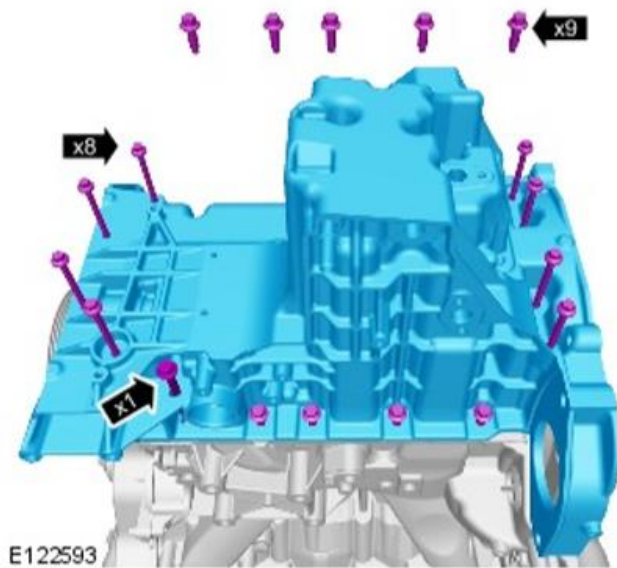

Reference	Designation	Tightening procedure
(1)	bolts - oil pump (*)	Pre-tighten to 4 Nm
		Tightening torque to 9 Nm
(2)	Oil level sensor	Tightening torque to 27 Nm
(3)	bolts M8 - Engine sump (*)	Pre-tighten to 10 Nm
		Tightening torque to 23 Nm
(4)	bolts M6 - Engine sump (*)	Pre-tighten to 4 Nm
		Tightening torque to 10 Nm
(5)	Oil suction strainer	Tightening torque to 9 Nm

(6)	bolts - sump (*)	Pre-tightening to 4 Nm
		Tightening torque to 9 Nm
(7)	drain plug	Tightening torque to 23 Nm
(8)	Lower dipstick guide tube	Tightening torque to 9 Nm
(9)	Oil deflector	Tightening torque to 9 Nm
(10)	Piston skirt spray jets	Tightening torque to 10 Nm

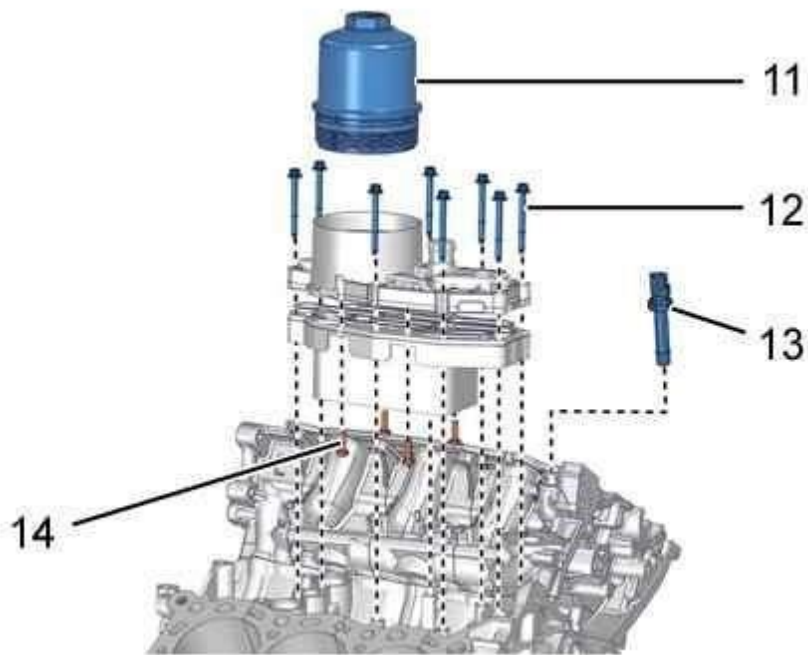
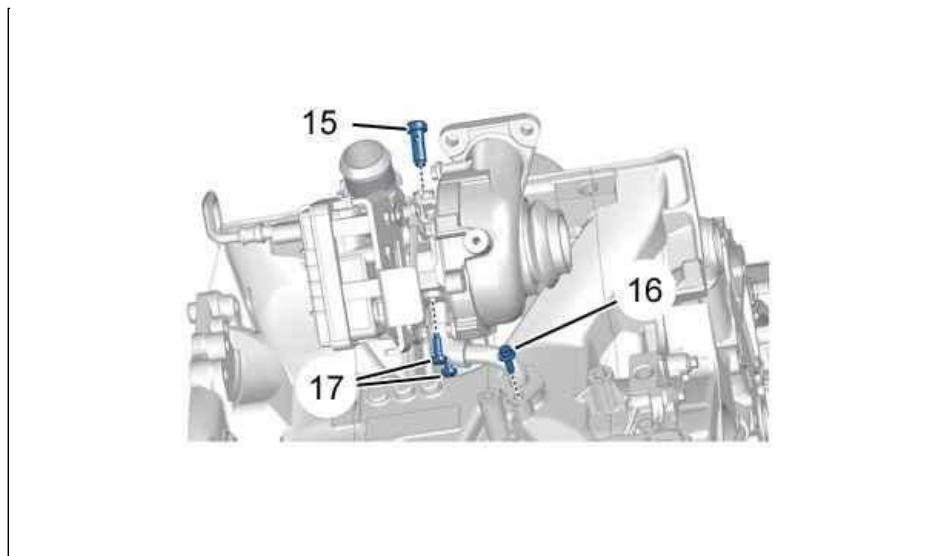
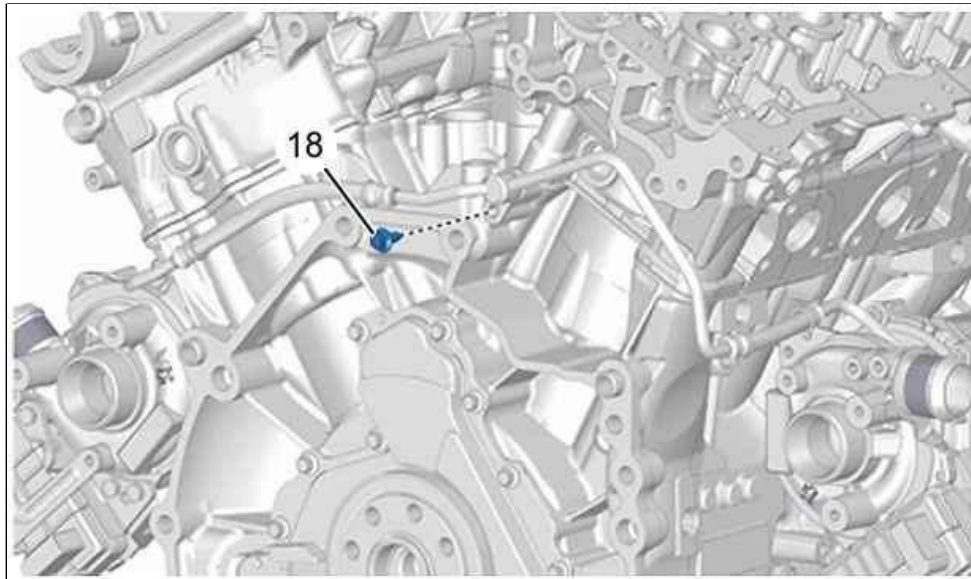

Figure : B1FB00QD

Reference	Designation	Tightening procedure
(11)	Oil filter cover	Tightening torque to 25 Nm
(12)	bolts - Oil filter support (*)	Tightening torque to 9 Nm
(13)	Oil pressure sensor	Tightening torque to 13 Nm
(14)	bolts - coolant/oil heat exchanger	Tightening torque to 9 Nm



Reference	Designation	Tightening procedure
(15)	bolts - Turbocharger lubrication feed pipe	Tightening torque to 30 Nm
(16)	bolts - Turbocharger lubrication return pipe -	Cylinder block Side - Tightening torque to 9 Nm
(17)	bolts - Turbocharger lubrication return pipe	Tightening torque to 9 Nm



Reference	Designation	Tightening procedure
(18)	bolts - Turbocharger lubrication feed pipe -	Cylinder block side - Tightening torque to 9 Nm

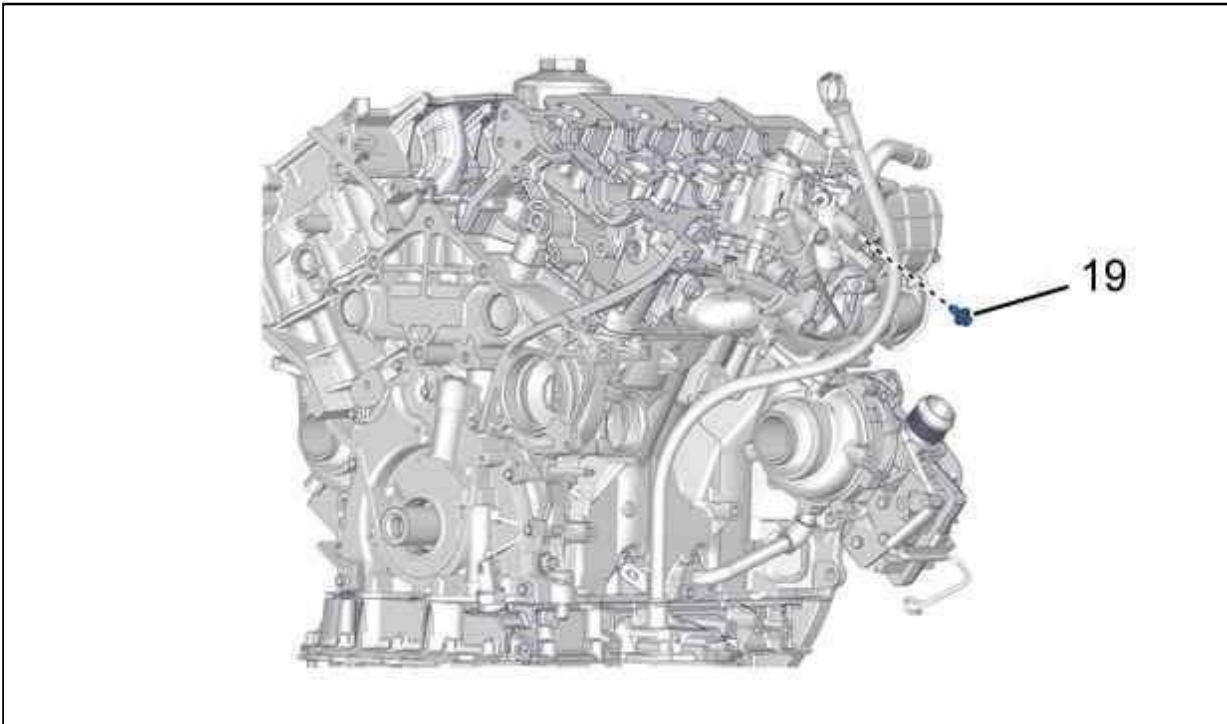

Figure : B1CB010D

Reference	Designation	Tightening procedure
(19)	bolts - Dipstick guide tube	Tightening torque to 9 Nm

5.1. Sequence of tightening the bolts (1)

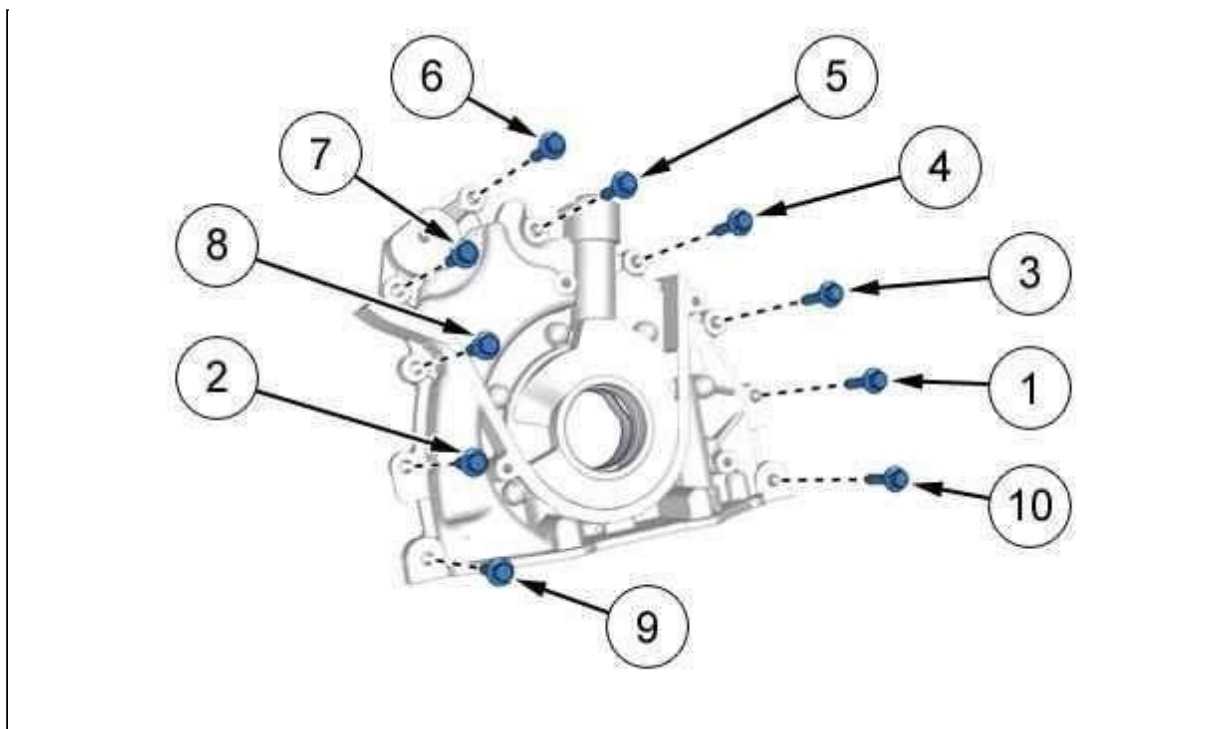

Figure : B1FB00RD

(1) Oil pump fixing bolts .

Tightening procedure : Fixing bolts of the oil pump : ☐ Tighten the 2 bolts (1) by hand (1 and 2)

1. Tighten the 8 bolts (1) by hand (From 3 to 10)
2. Pre-tighten the 10 bolts (1) to 4 Nm (From 1 to 10)
3. Tighten the 10 screws (1) to 10 Nm (From 1 to 10)

5.2. Sequence of tightening the bolts (3), (4)

(3) bolts M8 - Engine sump.

(4) bolts M6 - Engine sump.

DT20C Sump

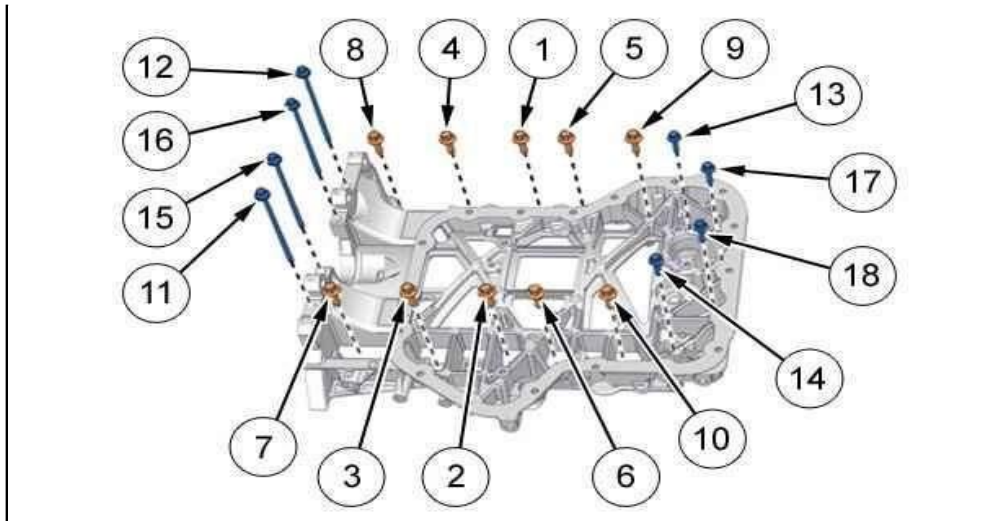
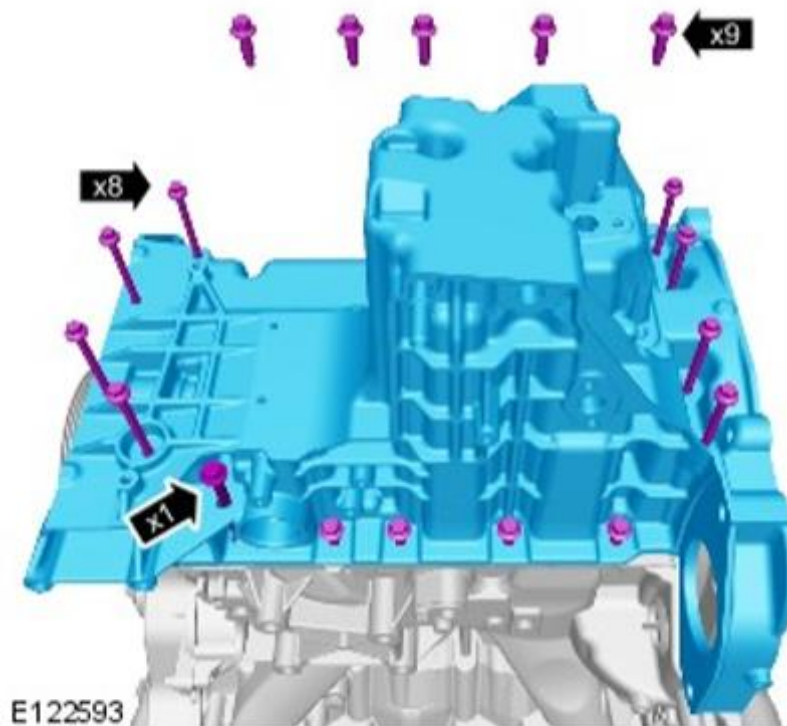

Figure : B1CB011D

Land Rover Sump

19



Tightening procedure : Engine sump :

1. Tighten the 18 bolts (3), (4) by hand (From 1 to 18)
2. Pre-tighten the 10 bolts (3) to 10 Nm (From 1 to 10)
3. Tighten the 10 screws (3) to 23 Nm (From 1 to 10)
4. Pre-tighten the 8 bolts (4) to 4 Nm (From 11 to 18)
5. Tighten the 8 screws (4) to 10 Nm (From 11 to 18)

5.3. Sequence of tightening the bolts (6)

ONLY DT20C Metal Sump/Pan

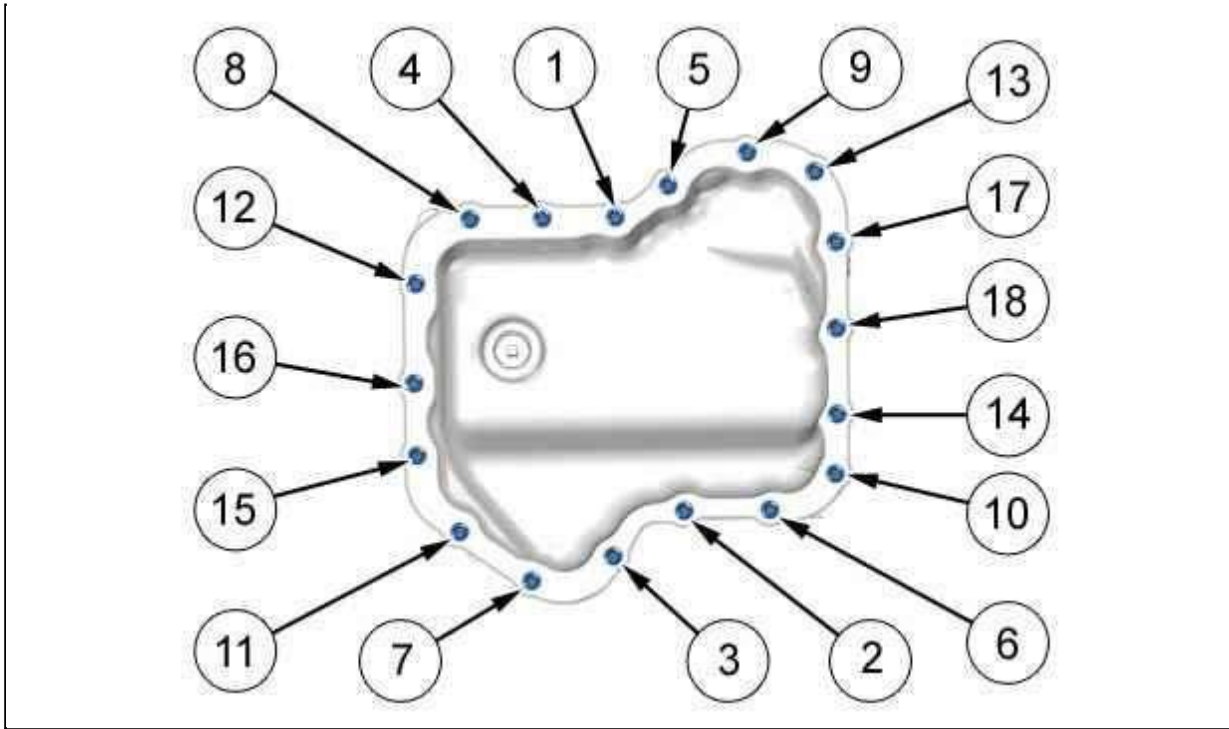

Figure : B1FB00SD

Tightening procedure - Fixing bolts of the oil sump :

1. Tighten the 4 bolts (6) by hand : In the following order (8, 10, 11, 13)
2. Pre-tighten the 18 bolts (6) to 4 Nm (From 1 to 18)
3. Tighten the 18 screws (6) to 10 Nm (From 1 to 18)

5.4. Sequence of tightening the bolts (12)

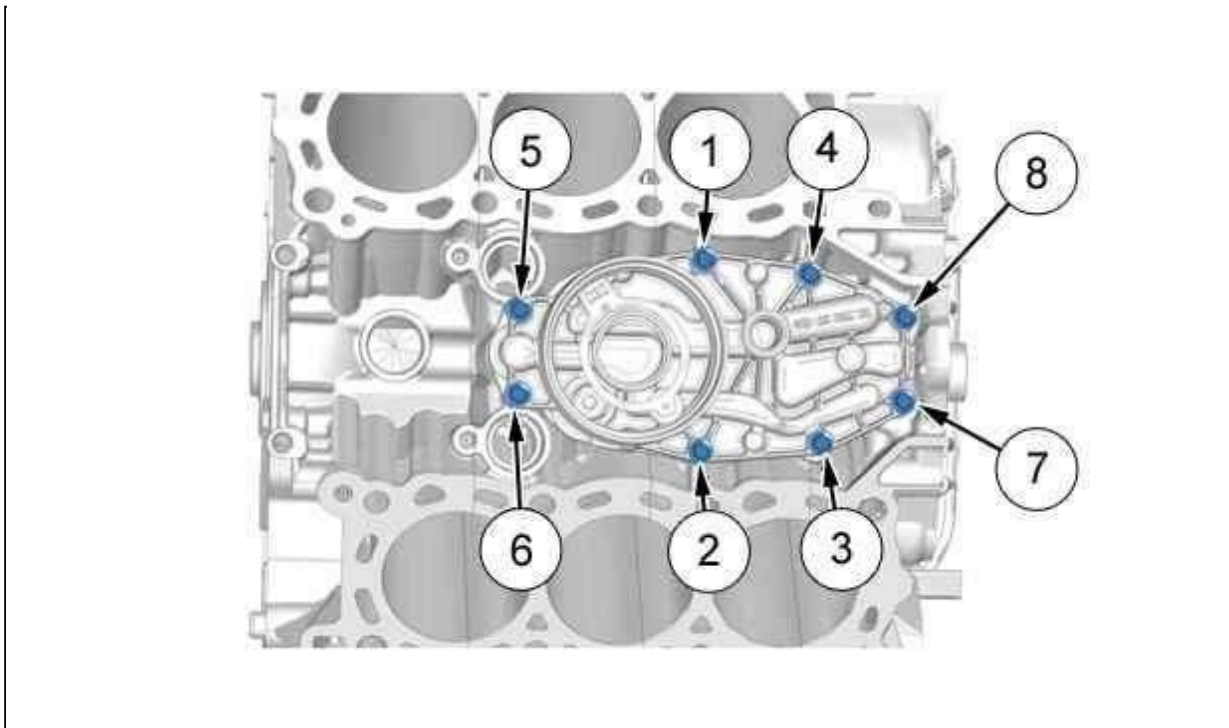

Figure : B1FB00TD

(12) bolts - Oil filter support.

Reference	Designation	Tightening procedure
(12)	bolts - Oil filter support (*)	Tightening torque to 9 Nm

6. Timing gear

6.1. Tightening torques

CAUTION : (*) Follow the tightening sequence.

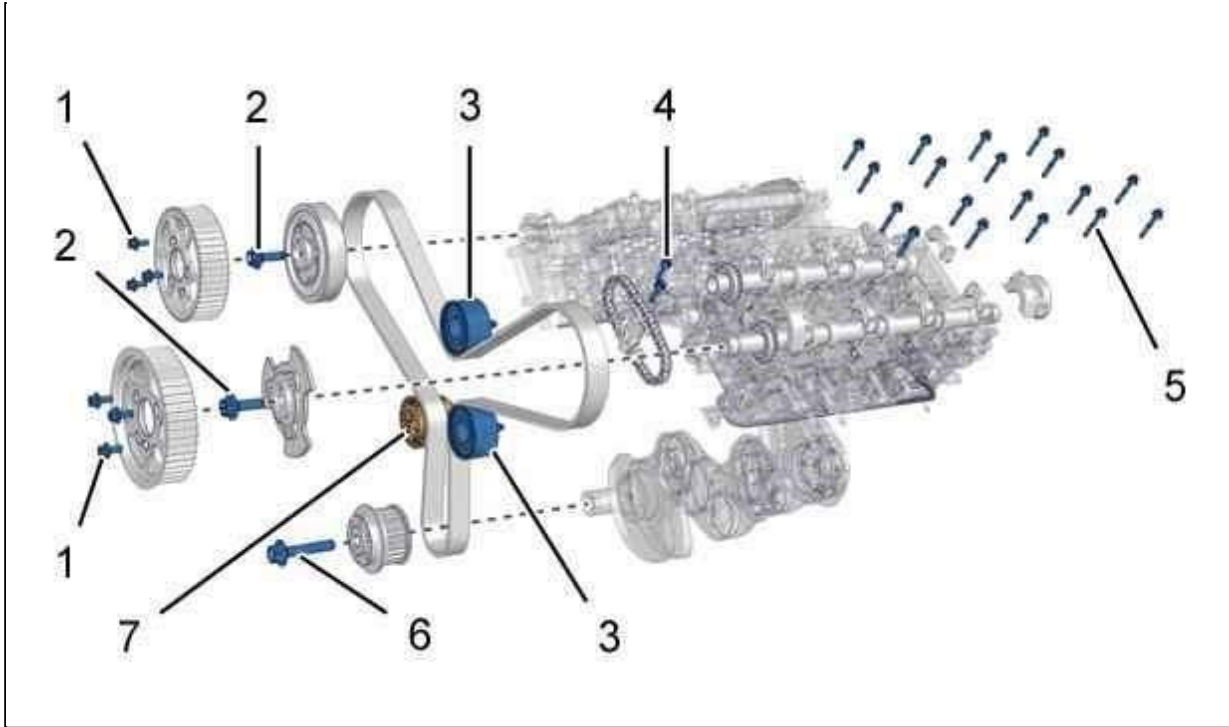

Figure : B1EB00AD

Reference	Designation	Tightening procedure
(1)	bolts - Camshaft pulleys	Tightening torque to 23 Nm
(2)	Camshaft pulley hub screws	Tightening torque to 80 Nm Angular tightening to 90°
(3)	Timing belt idler roller bolt	Tightening torque to 45 Nm
(4)	Camshaft timing chain tensioner bolt	Tightening torque to 10 Nm
(5)	Camshaft bearing bolts (*)	Pre-tighten to 5 Nm Tightening torque to 10 Nm
(6)	Screw fixing the timing pinion to the crankshaft	Tightening torque to 300 Nm Angular tightening to 90°
(7)	Timing belt tensioner roller bolt	Tightening torque to 26 Nm

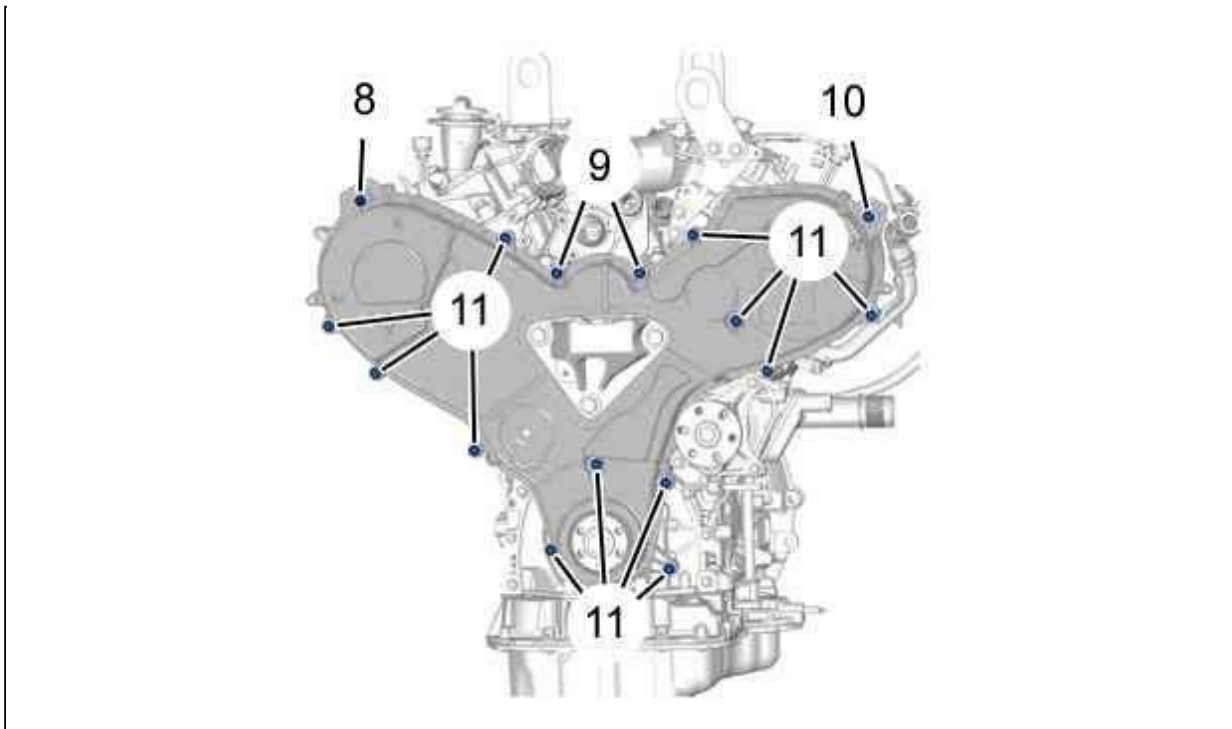

Figure : B1CB012D

Reference	Designation	Tightening procedure
(8)	nut - Timing cover	Tightening torque to 9 Nm
(9)	bolts M6x36 - Timing cover	Tightening torque to 9 Nm
(10)	bolts M6x30 - Timing cover	Tightening torque to 9 Nm
(11)	bolts M6x32 - Timing cover	Tightening torque to 9 Nm

6.2. Sequence of tightening the bolts (5)

CAUTION : The camshaft bearing caps are identified at "a" by a letter on the front cylinder head and a figure on the rear cylinder head and the notches "b" must point towards the centre of each cylinder head.

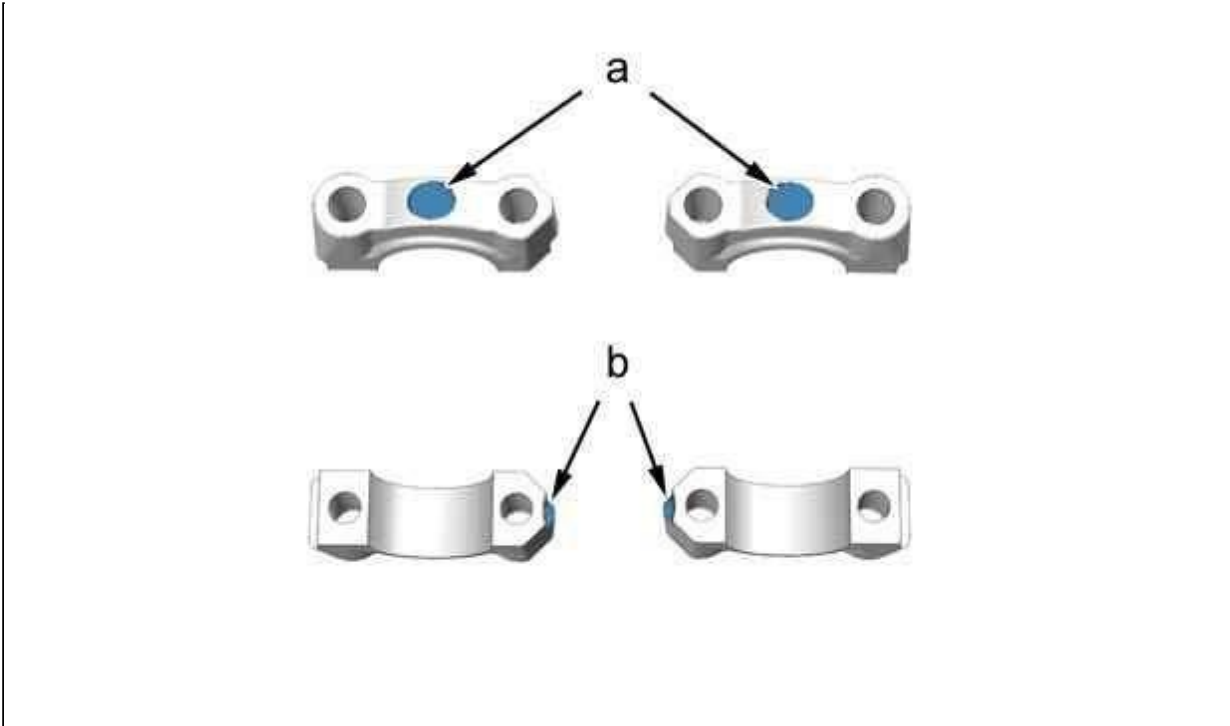

Figure : B1EB00BD

Camshaft bearing caps.

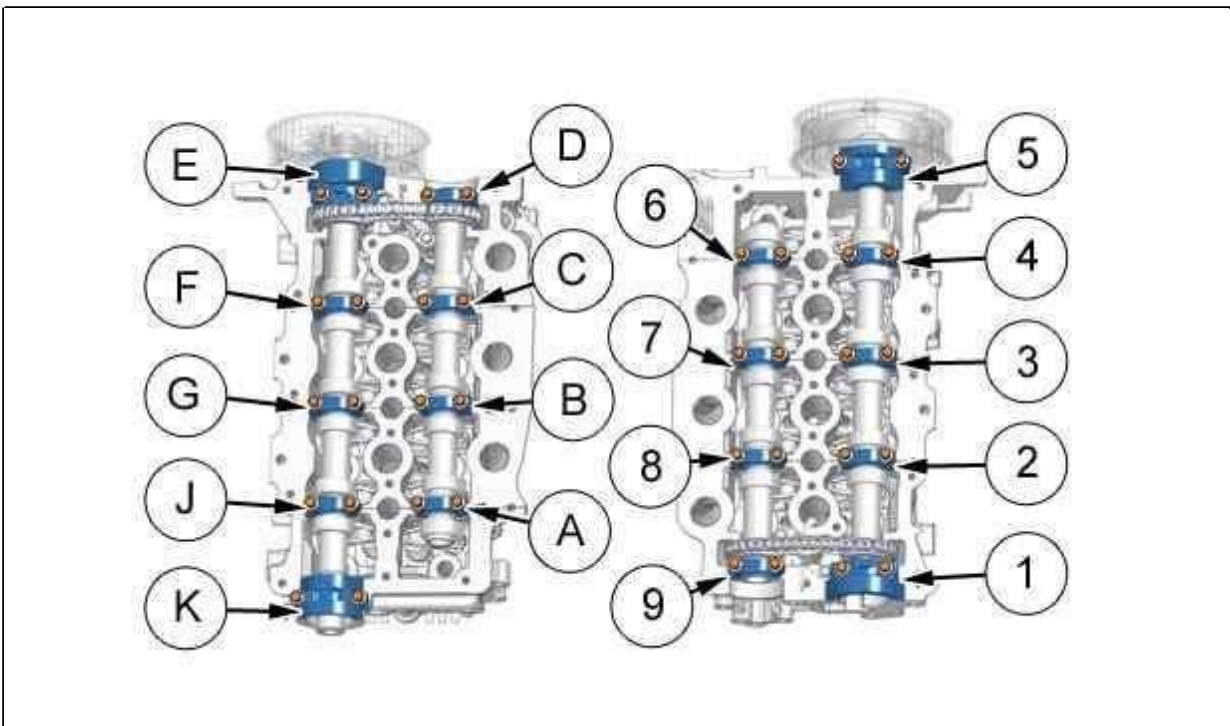

Figure : B1EB00CD

(5) Camshaft bearing bolts.

Tightening procedure : Camshaft bearing bolts :

1. Pre-tighten the screws (5) of the camshaft bearing caps **by hand**, in the following sequence: 9, 8, 7, 6, 4, 3, 2, D, C, B, A, J, G and F
2. Pre-tighten the screws (5) of the camshaft bearing caps to **5 Nm**, in the following sequence: , 8, 7, 6, 4, 3, 2, D, C, B, A, J, G and F
3. Tighten the screws (5) of the camshaft bearing caps to **10 Nm**, in the following sequence: 9, 8, 7, 6, 4, 3, 2, D, C, B, A, J, G and F

CAUTION : Place some sealing product LOCTITE 518 on the camshaft bearing caps 1, 5, E,K.

Refit the camshaft main bearing caps " 1", "5", "E" and "K" :

1. Pre-tighten the screws (5) of the camshaft bearing caps **by hand**, in the following sequence: 1, 5, E and K
2. Pre-tighten the screws (5) of the camshaft bearing caps to **5 Nm**, in the following sequence: 1, 5, E and K
3. Tighten the screws (5) of the camshaft bearing caps to **10 Nm**, in the following sequence: 1, 5, E and K

7. Injection system

7.1. Tightening torques

CAUTION : (*) Follow the tightening sequence.

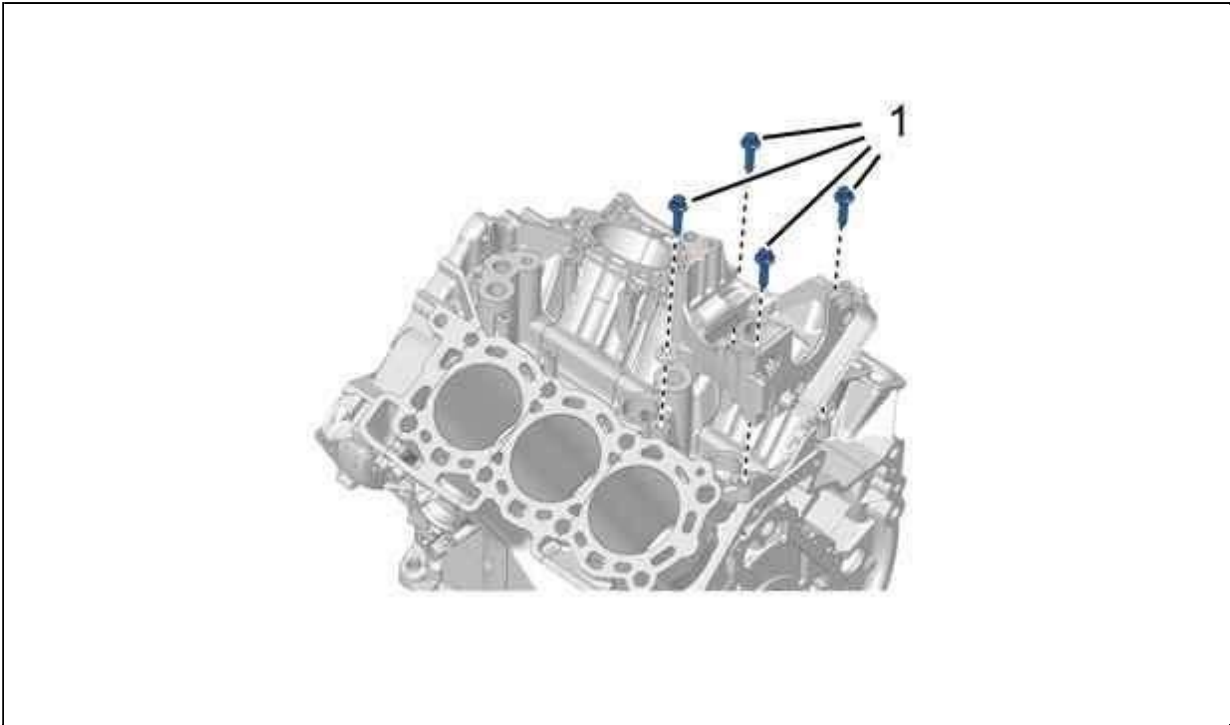

Figure : B1HB09TD

Reference	Designation	Tightening procedure (Nm)
(1)	bolts - Diesel injection pump bracket	Tightening torque to 23 Nm

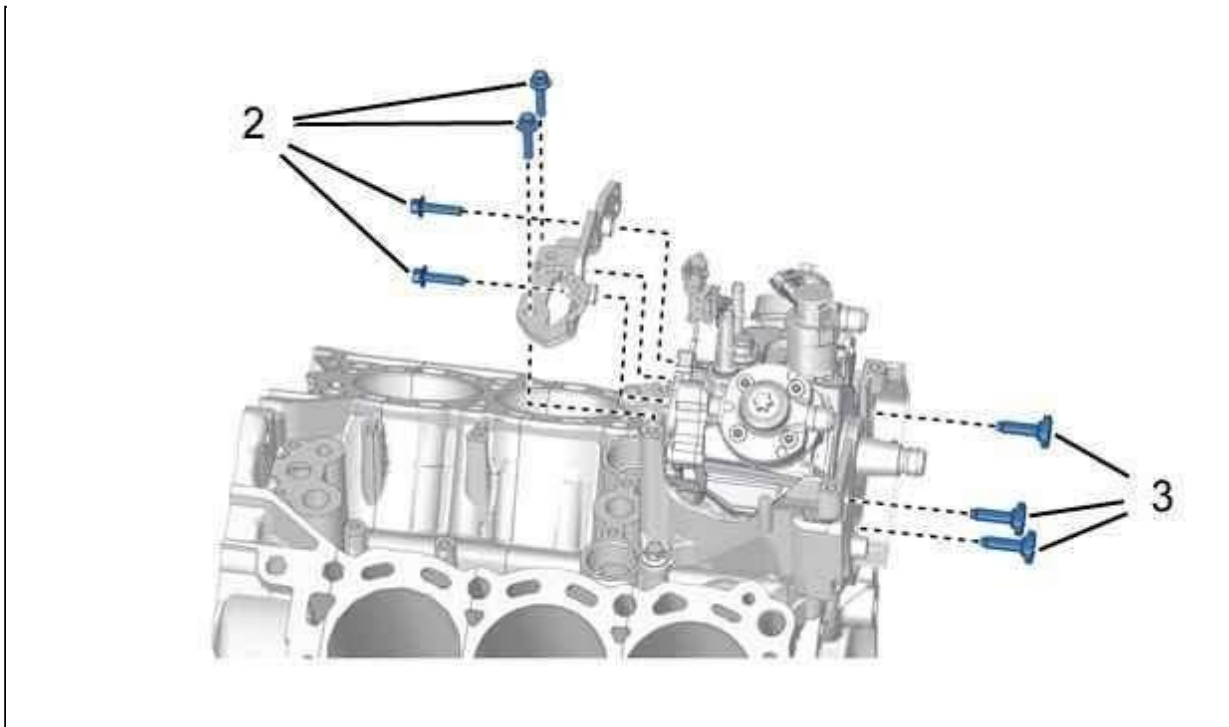
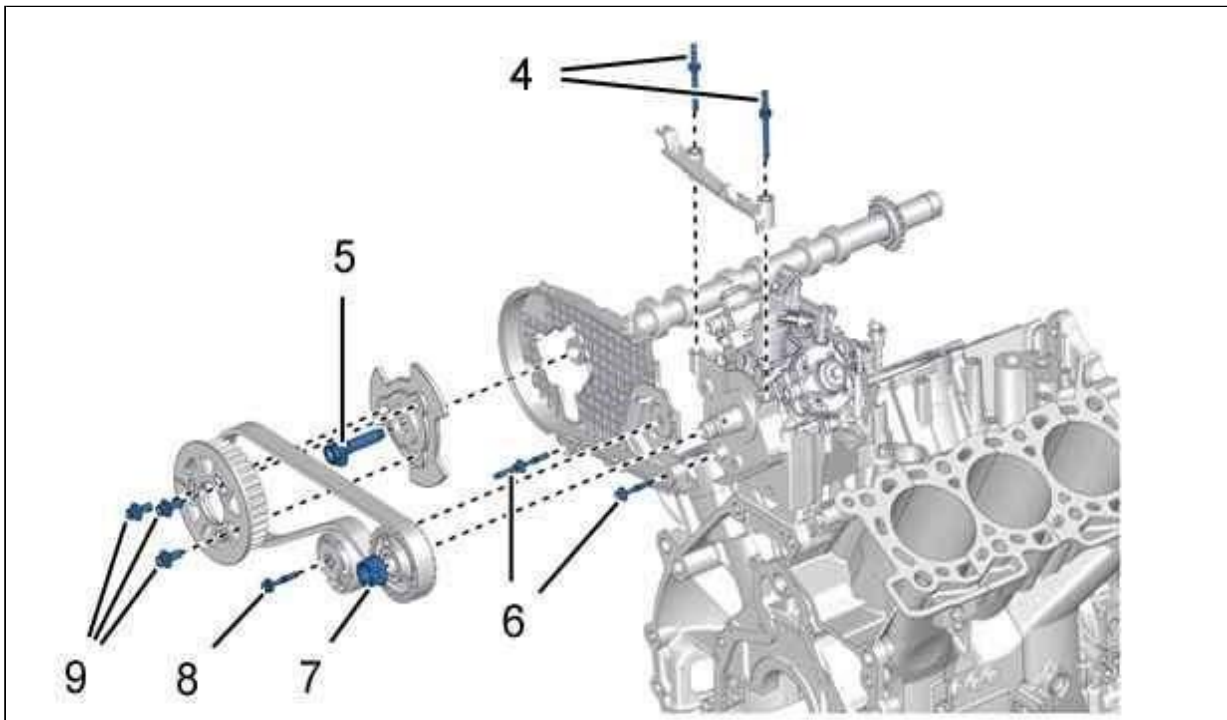

Figure : B1HB09UD

Reference	Designation	Tightening procedure
(2)	bolts - Diesel injection pump bracket	Tightening torque to 10 Nm
(3)	bolts - Diesel injection pump on support	Tightening torque to 23 Nm



Reference	Designation	Tightening procedure
(4)	Cover screw	Tightening torque to 9 Nm
(5)	bolts - Hub of the diesel injection pump drive pulley	Tightening torque to 80 Nm Angular tightening to 90°
(6)	Cover screw	Tightening torque to 9 Nm
(7)	Nut of the diesel injection pump pinion	Tightening torque to 50 Nm
(8)	bolts - Tensioner roller of the drive belt of the diesel injection pump	Tightening torque to 2, Nm
(9)	bolts - Drive pulley of the diesel injection pump	Tightening torque to 23 Nm

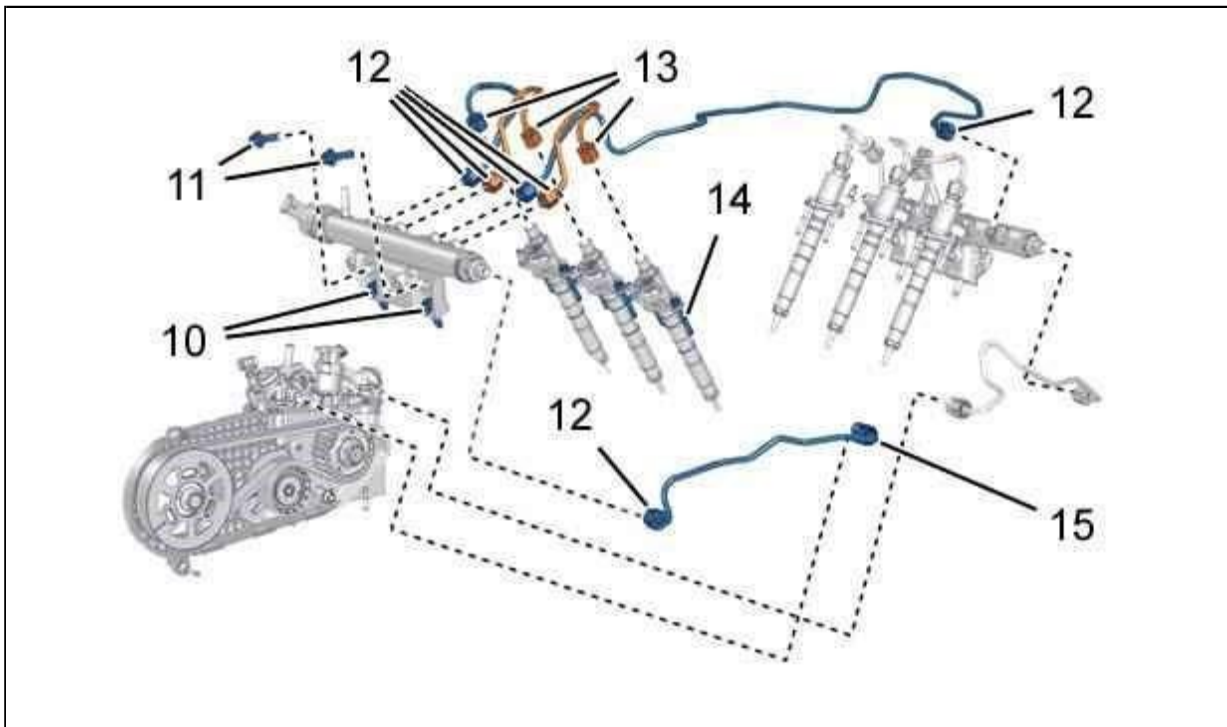

Figure : B1HB09VD

Reference	Designation	Tightening procedure
(10)	bolts - Injection rail mounting - Cylinder head	Tightening torque to 23 Nm
(11)	bolts - Injection rail mounting - Fuel high pressure common injection rail	Tightening torque to 23 Nm
(12)	Fuel high pressure common injection rail unions (*)	Pre-tighten to 15 Nm
		Tightening torque to 30 Nm
(13)	Unions on diesel injectors (*)	Pre-tighten to 15 Nm
		Tightening torque to 30 Nm
(14)	bolts - Diesel injector fixing clamps	Tightening torque to 9 Nm
(15)	Unions on diesel injection pump (*)	Pre-tighten to 15 Nm
		Tightening torque to 30 Nm

7.2. Order of tightening : Union pipes (12), (13), (15)

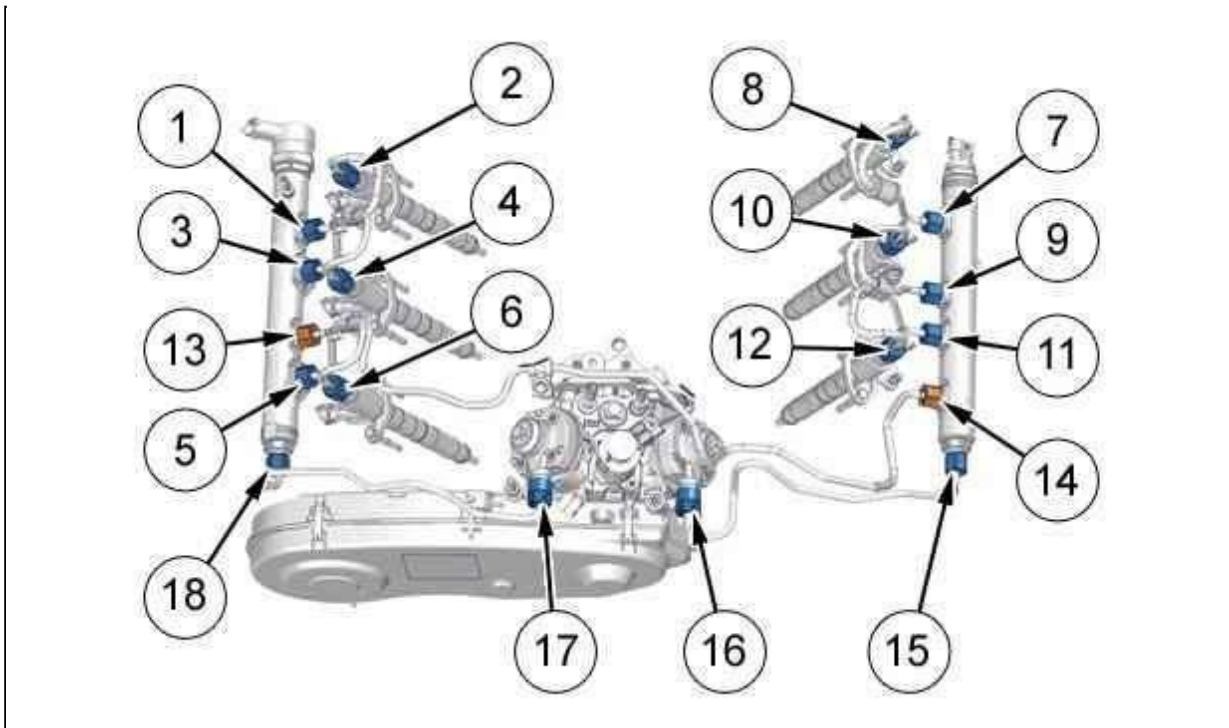

Figure : B1HB09WD

Unions on fuel high pressure common injection rails.

Unions on diesel injectors.

(15) Unions on diesel injection pump.

Tightening procedure : High-pressure fuel supply unions :

1. Pre-tighten the unions (12) of the common rails (13) and the injectors by hand (From 1 to 12)
2. Pre-tighten the unions (12) of the common rails (13) and the injectors : to 15 Nm (From 1 to 12)
3. Tightened the unions (12) of the common rails (13) and the injectors : to 30 Nm (From 1 to 12)

4. Pre-tighten the unions (12) of the common rails by hand (13 and 14)
5. Pre-tighten the unions (12) of the common rails : to 15 Nm (13 and 14)
6. Tightened the unions (12) of the common rails to 30 Nm (13 and 14)

7. Pre-tighten the unions (12) of the common rails (15) and the diesel injection pump by hand (From 15 to 18)
8. Pre-tighten the unions (12) of the common rails (15) and the diesel injection pump : to 15 Nm (From 15 to 18)
9. Tighten the unions (12) of the common rails (15) and of the diesel injection pump to 30 Nm (From 15 to 18)