

Fuel Filter Element - VIN Range: 07 MODEL YEAR->CURRENT (192502)

Removal



WARNING : Do not smoke or carry lighted tobacco or open flame of any type when working on or near any fuel related components. Highly flammable vapors are always present and may ignite. Failure to follow these instructions may result in personal injury.



WARNING : This procedure involves fuel handling. Be prepared for fuel spillage at all times and always observe fuel handling precautions. Failure to follow these instructions may result in personal injury.



WARNING : Do not carry or operate cellular phones when working on or near any fuel related components. Highly flammable vapors are always present and may ignite. Failure to follow these instructions may result in personal injury.



WARNING : If fuel contacts the eyes, flush the eyes with cold water or eyewash solution and seek immediate medical attention.



WARNING : If taken internally, do not induce vomiting, seek immediate medical attention. Failure to follow these instructions may result in personal injury.



WARNING : Wash hands thoroughly after fuel handling, as prolonged contact may cause irritation. Should irritation develop, seek medical attention.



WARNING : The spilling of fuel is unavoidable during this operation. Make sure that all necessary precautions are taken to prevent fire and explosion.



CAUTION : Diesel fuel injection equipment is manufactured to very precise tolerances and fine clearances. It is therefore essential that absolute cleanliness is observed when working with these components. Always install blanking plugs to any open orifices or lines. Failure to follow this instruction may result in foreign matter ingress to the fuel injection system.



CAUTION : Make sure the workshop area in which the vehicle is being worked on is as clean and as dust free as possible. Foreign matter from work on clutches, brakes or from machining or welding operations can contaminate the fuel system and may result in later malfunction.

1.



WARNING : Do not work on or under a vehicle supported only by a jack. Always support the vehicle on safety stands.

Raise and support the vehicle.

2 . Remove the transmission undershield.



Remove the 6 bolts.

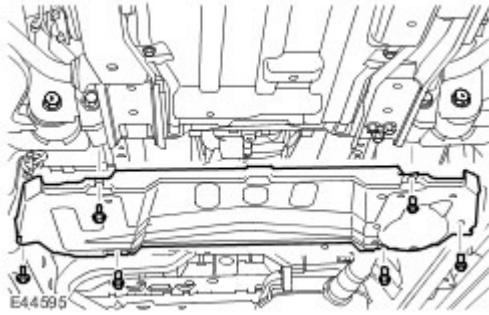

3.



WARNING : Observe due care when working near a hot exhaust system.

Remove the fuel filter heat shield.

- ▶ Remove the 3 bolts.

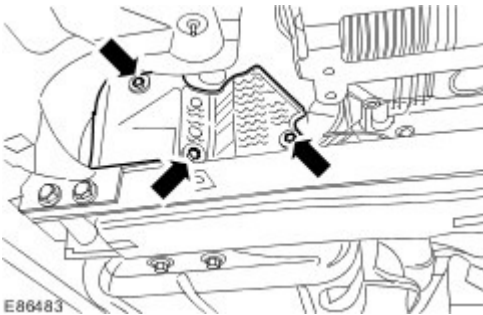

4 . Drain the fuel filter element.

- ▶ Position a container to collect the fluid spillage.
- ▶ Loosen the nut.
- ▶ Attach a suitable drain tube to the water-in-fuel sensor drain port.
- ▶ Remove the drain tube.
- ▶ Tighten the nut.



5.



CAUTION : Make sure that the area around the component is clean and free of foreign material.

Remove the fuel filter element.

- ▶ Disconnect the water-in-fuel sensor electrical connector.



6 . Remove the water-in-fuel sensor.

- Remove and discard the sealing washer.
- Discard the fuel filter element.

Installation

1 .



CAUTION : Make sure that the mating faces are clean and free of foreign material.

Install the water-in-fuel sensor.

- Remove and discard the water-in-fuel drain plug from the new fuel filter element.
- Install a new sealing washer.

2 . **NOTE :**

Make sure that the fuel filter element is correctly aligned. Failure to follow this instruction may result in damage to the vehicle.

Install the fuel filter element.

- Connect the water-in-fuel sensor electrical connector.
- Remove the container.

3 . Install the fuel filter heat shield.

- Tighten the bolts to 6 Nm.

4 . Install the transmission undershield.

- Tighten the bolts to 10 Nm.

5 . Carry out the low-pressure fuel system bleeding.

For additional information, refer to : Fuel System - General Information, 310-00.