

Roof Opening Panel

Roof Opening Panel Components

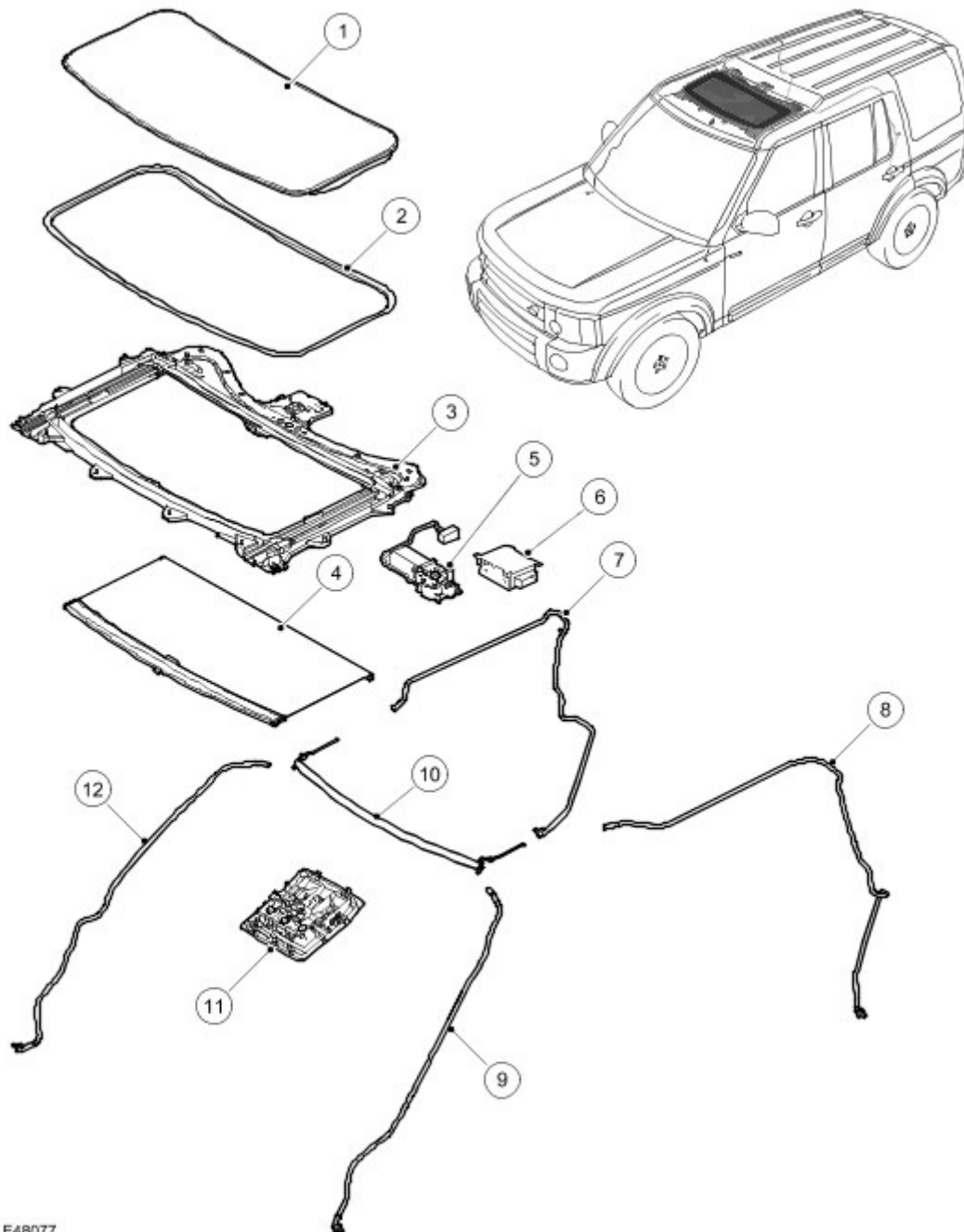

E48077

Item	Part Number	Description
1	-	Glass panel assembly
2	-	Glass panel seal
3	-	Frame assembly
4	-	Sunblind
5	-	Motor
6	-	Control module
7	-	RH rear drain tube
8	-	LH rear drain tube

9	-	LH front drain tube
10	-	Deflector
11		Access panel
12		RH front drain tube

GENERAL

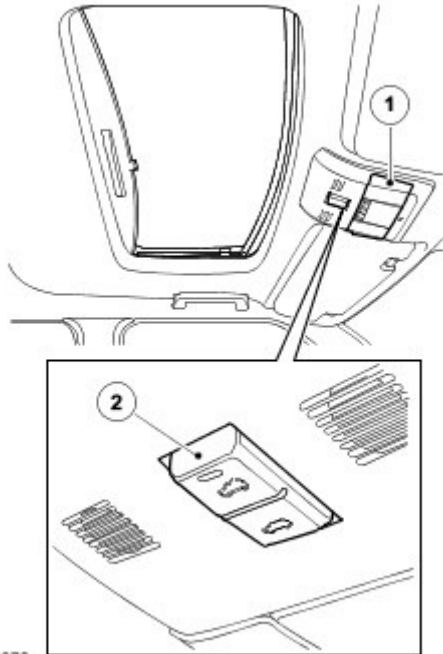

E48078

Item	Part Number	Description
1	-	Access panel
2	-	Switch

The sunroof is electrically operated through a two-way rocker switch located on the roof mounted centre console. An electric motor, attached to the sunroof frame, drives the glass sunroof panel to the tilt or open positions. The glass panel is operated by two cables, which are driven by the motor.

The sunroof frame is bolted to eleven mounting points on the roof panel. The frame is a large injection moulding and supports all of the sunroof components. Two aluminium guides held in the frame, on each side. The sunroof motor attaches to the rear of this frame. The motor is supported on the frame with three screws.

The sunroof glass panel is attached to the guide at the extreme front and rear. The tilt and slide positions are achieved by driving the attachment points on the panel over two fixed curves, one in the guide and one fixed to the panel.

Sunroof Motor

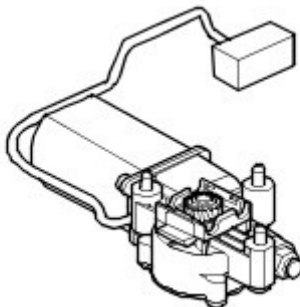

E48079

The sunroof motor has a worm drive, which drives a gear in a cast housing attached to the end of the motor. The

gear has a small pinion gear attached to the outer part of its spindle. The pinion engages with the helixed cables to form a rack and pinion drive. Rotation of the motor turns the pinion, which in turn drives the cables in the required direction.

Sunroof Motor Pin Out Information

Pin	Description	Input/Output
1	Hall sensor Ground	-
2	Hall sensor Supply	Input
3	Hall sensor Speed	Output
4	Hall sensor Direction	Output
5	Motor A	Input
6	Motor B	Input

The two cables are attached either side of the pinion. One end of each cable is attached to the guide. The opposite end is trapped in its position on the pinion by a metal insert in the frame. The cables run in channels in the frame to the guides. As the sunroof panel is closed, the cables are pushed through channels in the rear of the frame. The displaced cable is guided into a further two channels in the frame, which protect the cable and prevent the cable snagging creating noise. The cables are made from rigid spring steel and therefore can pull as well as push the sunroof along the guides.

A sun blind is also located in the guides integrated into the frame. The sunblind is operated manually, independently of the glass panels position. To move to the closed position the sunblind handle is pushed forward until it latches into the frame. To move the sunblind to the open position the sunblind handle is pushed up, to unlatch and either released or retracted to the open position. The sunblind can only be in either the fully open or fully closed positions.

Drain hoses are connected to the front and rear corners of the frame. The drain hoses are located inside of the cabin on the 'A' and 'C' post pillars to allow water, which has collected in the frame to escape. A one-way valve is fitted to the end of each drain hose to prevent the ingress of dirt and moisture.

SUNROOF CONTROL MODULE

The sunroof control module is mounted on the rear of the frame, and is connected to the motor at one end as described above, and to the vehicle electrical system at the other. It takes the inputs from the vehicle, such as LIN (Local Interconnect Network) bus signals and switch signals, and controls motor movement appropriately. It also contains the algorithm for the anti-trap system.

Sunroof Control Module Pin Out Information

Pin	Description	Input/Output
1	Switch Ground	-
2	Switch Open	Input
3	Switch Close	Input
4	Not used	-
5	Not used	-
6	Emergency (see note below)	Input
7	ECU Ground	-
8	Battery	Input
9	Not used	-
10	Not used	-
11	Not used	-
12	LIN	Input

NOTE :

Pin 6 is for use in an emergency only in the event of the vehicle LIN bus not being functional. It is not connected on the vehicle harness or in the connector.

NOTE :

Putting pin 6 to ground will enable the sunroof control module but without one touch operation or anti trap. The sunroof will not require re-calibrating unless the battery has been disconnected.

NOTE :

The sunroof control module will remain awake and enabled until pin 6 is disconnected again. Under no circumstances is this pin to be left grounded for long periods.

NOTE :

There is no emergency key access in the headlining for manual sunroof operation should the motor fail for any reason.

OPERATION

The sunroof can be operated with the ignition switch in position I or II. The sunroof can also be operated for up to 40 seconds after the ignition is switched off provided the driver's or passenger's door is not opened. During the 40 second period the one touch function is inoperative.

The motor contains a micro-switch and a Hall effect sensor. Two gears, driven by the motor at one end of the pinion drive spindle, trip the micro-switch every thirteen revolutions of the spindle. When the micro-switch is tripped, the sunroof control module senses an open circuit signal. The sunroof control module, to calculate the exact position of the sunroof, uses the signal from the micro-switch combined with signals received from the Hall effect sensor. The Hall effect sensor is also responsible for the operation of the anti-trap function.

If the anti-trap feature is activated while the sunroof is closing, the roof panel is reversed for 200mm or as far as possible. The Hall sensor, located in the sunroof motor, monitors the speed of the motor and if the speed decreases below a set threshold, indicating an obstruction, the power feed to the motor is reversed so the sunroof goes back. In an emergency the anti-trap function can be overridden by holding the sunroof switch in the closed position.

Tilt

With the sunroof panel closed, pushing the upper part of the rocker switch operates the sunroof motor to 'tilt' the rear of the sunroof upwards. The motor operates for as long as the switch is operated until the glass is tilted to its full extent. If the switch is released before the full tilt position is reached, the sunroof panel stops at the chosen position. A single press (between 0.5 and 1 second) of the switch operates the motor so that the panel automatically retracts to the fully tilted position.

When the tilt function is requested, the cables pull the guide rearward, forcing the panel attachment up a curve, which raises the sunroof panel to the tilt position.

With the sunroof panel in the tilted position, pushing the lower part of the rocker switch operates the sunroof motor to lower the sunroof panel. The motor operates to lower the panel for as long as the switch is operated until the panel is fully lowered. If the switch is released before the fully lowered position is reached, the sunroof panel stops at the chosen position.

Open (slide)

With the sunroof panel tilted, pushing the upper part of the rocker switch operates the sunroof motor to raise the sunroof panel and retract it backwards. A single press (between 0.5 and 1 second) of the switch operates the motor so that the panel automatically retracts to the fully open position. When the panel retracts, a wind deflector automatically raises at the front of the sunroof aperture, which serves to reduce wind noise.

When the open function is requested, the cables pull in a rearward direction, driving the glass panel attachments to slide the panel over the exterior roof skin.

With the sunroof panel half or fully open, pushing the lower part of the switch operates the motor to close the sunroof panel. A single press (between 0.5 and 1 second) of the switch operates the motor so that the panel automatically closes to the fully tilted position.

If only partial opening or closing is desired, pressing the switch momentarily (less than 0.5 seconds) in either direction will stop the sunroof panel movement. When movement is desired in either direction, pressing the switch will operate the motor to move the panel.

The sunroof has an 'anti-trap' function which prevents the sunroof panel from closing if an obstruction is sensed. When an obstruction is sensed, the motor will automatically retract the panel by 200mm or as far as possible. When the obstruction is removed, the panel can be closed by the normal method.

Battery Disconnection

If the battery has been disconnected, the one touch and anti-trap function will become inoperative. Pressing the lower part of the sunroof switch for 20 seconds will start the sunroof's calibration routine. The sunroof will complete a full cycle in order to re-learn the parameters required for one-touch open and close and the anti-trap function. The sunroof will still have manual movement available until the sunroof is re-calibrated.

SUNROOF CONTROL DIAGRAM

NOTE :

A = Hardwired; B = Local Interconnect Network (LIN) bus

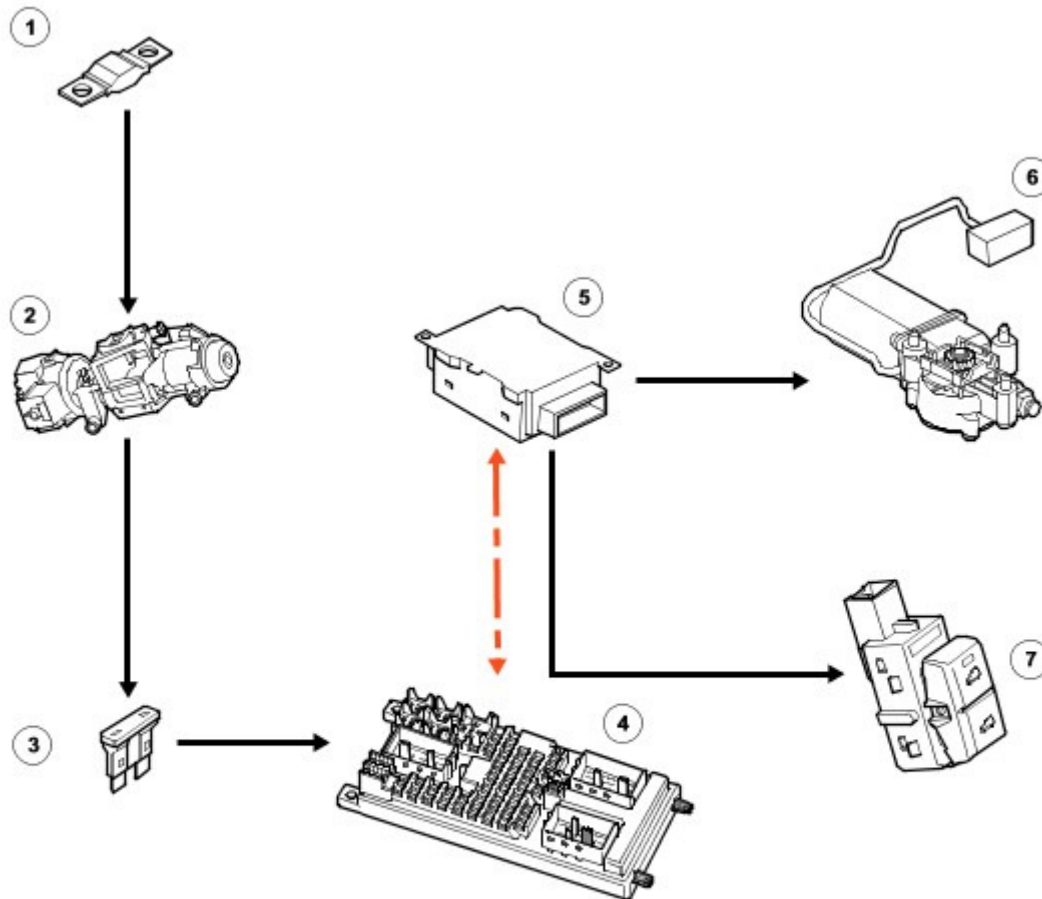

E48080



Item	Part Number	Description
1	-	Fusible link 11
2	-	Ignition switch
3	-	Fuse 20
4	-	Central Junction Box (CJB)
5	-	Sunroof control module
6	-	Sunroof motor
7	-	Sunroof switch