



TECHNICAL INFORMATION
H 408x BM Speed Ovens

Technical Information

Table of Contents

A	Warning and Safety Instructions	6
1	General Information.....	6
2	Discharging the High-Voltage Capacitor	6
3	Microwave Energy.....	7
4	Precautions to Be Observed Before and During Service Work to Avoid Possible Exposure to Excessive Microwave Energy	8
B	Modification History.....	8
C	Technical Data.....	9
D	Component Layouts	11
1	Appliance Overview.....	11
2	Overview of Controls	12
3	Electrical Components	13
3.1	H 4080 BM.....	13
3.2	H 4082 BM and Later	14
011	Casing, Door Lock	15
4	Service	16
4.1	Installation Procedure.....	16
4.2	Before Using the Appliance	17
4.3	Appliance Removal (From a Cabinet)	18
4.4	Outer Side Cover Removal.....	18
4.5	Side Panel Removal	18
4.6	Removing the Door Lock Torsion Spring.....	18
4.7	Door Latch Removal.....	19
4.8	Door Lock Removal	20
4.9	Door Switch Adjustment	21
012	Air Duct, Magnetron.....	25
1	Technical Data	26
2	Function.....	26
2.1	Air and Vapor Ducting	26
2.2	Fan Cooldown	27
2.3	Microwave Operation.....	27
4	Service	29
4.1	Front Air Duct Removal (up to Machine No. 10/59114003).....	29
4.2	Rear Air Duct with Cooling Fan (M2/1) Removal (up to Machine No. 10/59114003)	30
4.3	Air Duct Removal (after Machine No. 10/59114004).....	31
4.4	Removing the Release Element (Y56)	33
4.5	Cooling Fan (M2/1) Removal (up to Machine No. 10/59114003)	33
4.6	Cooling Fan (M2/1) Removal (after Machine No. 10/59114004).....	34
4.7	Testing the Magnetron (G2) Filament.....	34
4.8	Magnetron Test	35
4.9	Magnetron (G2) Removal	35
4.10	Removing High-Voltage Capacitor A4.....	36

Technical Information

4.11	Microwave Output Test.....	37
4.12	High-Voltage Transformer Test	37
4.13	Transformer (1T1) Removal	38
4.14	High-Voltage Capacitor Test	38
4.15	Checking High-Voltage Capacitor A4 for Grounding	39
4.16	Diode V1 Test.....	39
4.17	Checking Protective Diode V6.....	40
4.18	No Microwave Power – Diagnosis Procedure	40
020	Door.....	43
4	Service	44
4.1	Door Seal Removal	44
4.2	Removing the Door Outer and Middle Panes.....	44
4.3	Removing the Door Handle	45
4.4	Removing the Door Inner Pane	45
4.5	Removing the Door, Complete with Hinges.....	45
4.6	Door Hinge Removal	46
031	Oven Cavity, Wave Distribution	47
1	Technical Data	48
3	Fault Repair.....	48
3.1	Iridescent Shine in Oven Cavity (H 4082 BM)	48
4	Service	48
4.1	Removing Wave Distributor Motor M21.....	48
4.2	Halogen Lamp Removal	50
4.3	Measuring the Temperature in the Middle of the Oven Cavity	50
032	Convection Fan, Heaters	52
1	Technical Data	53
2	Function.....	53
2.1	Safety Cutoff.....	53
2.2	Heater Element Timing.....	53
2.3	Heater Element Switching in Operating Modes	54
2.4	Convection Fan	54
4	Service	54
4.1	Fan Impeller Removal	54
4.2	Convection Fan (M2/2) Removal.....	55
4.3	Removing Convection Heater Element R14.....	56
4.4	Convection Thermostat Removal	56
4.5	Removing the PT1000 Temperature Sensor (1R30).....	56
4.6	Removing Broil Heater Element R15.....	57
040	Control Panel, Electrical System	58
2	Function.....	59
2.1	Navitronic Touch Display	59
2.2	Connectors on Power Electronic EPL (1N1) (H 4080 BM Only).....	61
2.3	Connectors on Power Electronic ELP (1N1) (H 4082/4/6/8 BM).....	63
3	Fault Repair.....	65
3.1	Fault Code Summary.....	65
3.2	F05 – Short Circuit, Oven Temperature Sensor	66
3.3	F06 – Open Circuit, Oven Temperature Sensor	66
3.4	F44 – Control Electronic/Power Electronic Interface Defective	66

Technical Information

3.5	F54 – Short Circuit, Roast Probe.....	67
3.6	F55 – Safety Cutoff.....	67
3.7	F60 – Temperature of Power Electronic Too High	67
3.8	Incorrect Language Was Set.....	67
3.9	Time Display in 24-Hour Format/12-Hour Format	67
3.10	Oven Light Goes Out/Does Not Go Out	68
3.11	Modes in the Main Menu Were Changed	68
3.12	Cooking Process Does Not Start.....	68
3.13	Recommended Temperatures Are Changed.....	68
3.14	Display Dims.....	68
3.15	Display Is Too Bright/Too Dark.....	68
3.16	Displays Look Different.....	68
3.17	Buzzer Tone Too Loud/Too Soft	69
3.18	System Lock Cannot Be Activated	69
3.19	Weight in Pounds	69
3.20	Temperature in °C/°F.....	69
3.21	Appliance Does Not Heat	69
3.22	Fuse Trips.....	69
3.23	Roast Probe Shows Wrong Values	70
3.24	Safety Relay (K1) Trips	70
4	Service	71
4.1	Programming Mode Overview (H 4080 BM).....	71
4.2	Programming Mode Overview (H 4082/4/6/8 BM).....	73
4.3	Service Mode Overview (H 4080 BM)	75
4.4	Service Mode Overview (H 4082/4/6/8 BM)	77
4.5	Reading and Deleting the Fault Memory	79
4.6	Fascia Panel Removal.....	79
4.7	Removing the Fascia Panel with Support Plate	80
4.8	Support Plate Removal.....	81
4.9	Power Electronic Removal	81
080	Technical Service Bulletins.....	82
1	H4XXX Cooling Fan Behavior	82
2	H 4080 BM Control Panel Fogging.....	82
3	Speed Oven Broil Element Replacement.....	83
4	Speed Ovens: Optional Waveguide Cover.....	83

List of Figures

Figure A-1:	Discharging the High-Voltage Capacitor	7
Figure D-1:	Overview of Appliance (Front View).....	11
Figure D-2:	Overview of Controls (H 4082 BM Shown)	12
Figure D-3:	H 4080 BM Component Layout.....	13
Figure D-4:	H 4082/4/6/8 BM Component Layout.....	14
Figure 011-1:	Handling Instructions Sheet (Shipped with Appliance).....	16
Figure 011-2:	Retaining Screws.....	17
Figure 011-3:	Door Lock Torsion Spring	19
Figure 011-4:	Ducting and Door Latch	20
Figure 011-5:	Wire Bracket and Hooks	20

Technical Information

Figure 011-6: Door Lock Removal	21
Figure 011-7: Magnetic Strips	23
Figure 011-8: Door Safety Switches	23
Figure 011-9: Right Safety Switch 3F6/6 and Screw	24
Figure 012-1: Ducting.....	27
Figure 012-2: Magnetron and High-Voltage Components	28
Figure 012-3: Microwave Components	29
Figure 012-4: Front Air Duct Removal	30
Figure 012-5: Rear Air Duct Removal	31
Figure 012-6: Air Duct Removal, Step 1	32
Figure 012-7: Air Duct Removal, Step 2	32
Figure 012-8: Release Element Removal	33
Figure 012-9: Cooling Fan Removal	34
Figure 012-10: Magnetron Removal	36
Figure 012-11: High-Voltage Transformer with Test Points Marked	37
Figure 012-12: Diode V1 Test Circuit.....	39
Figure 020-1: Door Pane Removal	44
Figure 020-2: Door Hinge Removal	46
Figure 031-1: Wave Distributor Motor Removal	49
Figure 031-2: Temperature Test	51
Figure 031-3: Sample Measurement with an Ambient Temperature of 20°C (68°F)	51
Figure 032-1: Convection Plus, Auto Roast	54
Figure 032-2: Broil, Convection Broil	54
Figure 032-3: Microwave.....	54
Figure 032-4: Microwave + Convection Plus, Microwave + Auto Roast (Sequential Operation)	54
Figure 032-5: Microwave + Broil, Microwave + Convection Broil (Sequential Operation)	54
Figure 032-6: Fan Impeller Removal.....	55
Figure 032-7: Broil Heater Element Removal	57
Figure 040-1: Navitronic Display (H 4080 BM Shown).....	59
Figure 040-2: Optical Interface.....	60
Figure 040-3: Power Electronic (H 4080 BM)	61
Figure 040-4: Power Electronic (H 4082/4/6/8 BM)	64
Figure 040-4: Fascia Panel Removal.....	80

List of Tables

Table C-1: US Data Sheet	10
Table 012-1: Technical Data	26
Table 012-2: High-Voltage Transformer Checks.....	37
Table 031-1: Technical Data	48
Table 032-1: Technical Data	53
Table 040-1: Power Electronic Connections (H 4080 BM).....	63
Table 040-2: Power Electronic Connections (H 4082/4/6/8 BM).....	65
Table 040-3: Fault Codes.....	66
Table 040-4: H 4080 BM Programming Mode	73
Table 040-5: H 4082/4/6/8 BM Programming Mode	75
Table 040-6: Service Mode (H 4080 BM).....	77
Table 040-7: Service Mode (H 4082/4/6/8 BM).....	78

Technical Information

A Warning and Safety Instructions**1 General Information****Danger!**

- Normally when the oven is switched off, the built-in discharge resistors in the high-voltage capacitors discharge the capacitors.
- **For safety reasons, it is important to ensure that this discharge takes place by always short-circuiting the high-voltage capacitors before starting any maintenance or repair work. See Section A-2 for instructions.**
- When the oven is connected to the power supply, the following components have potentially lethal voltage applied to them:
 - High-voltage transformer (T1)
 - Capacitor (high-voltage circuit) (A4)
 - Diode (V1)
 - Protective diode (V6)
 - Magnetron
- **The high-voltage circuit continues to have power present even with the appliance unplugged!**

Note:

- Before starting any service work, disconnect the machine from the power supply. Service and repair work should only be carried out by qualified persons in accordance with all appropriate local and national safety regulations.
- When carrying out measurements on an electronic connected to the power supply, always use narrow measuring probes. Contacts are very closely spaced and using thicker probes may cause short circuits.

2 Discharging the High-Voltage Capacitor**Note:**

Although the high-voltage capacitor contains an internal bleed resistor to automatically discharge the capacitor, the following procedure must be performed! **Do not** rely on a functioning resistor!

1. Unplug the appliance.
2. Remove the screws securing the appliance lid. Remove the lid.
3. Using an insulated-handled screwdriver, touch the blade from one terminal on the capacitor to the other terminal on the capacitor, as shown in Figure A-1. **This may result in a rather startling “pop!”**
4. Using the same insulated-handled screwdriver, touch the blade from each terminal on the capacitor to the frame (ground) of the appliance.

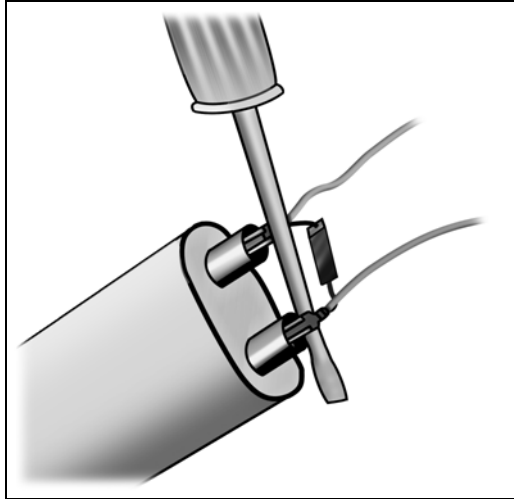

Figure A-1: Discharging the High-Voltage Capacitor

3 Microwave Energy

Microwave energy is created by the magnetron or another microwave generator.

Danger!

The human body must not be subjected to any microwave energy under any circumstances, as this could result in serious internal injuries.

The following measures must always be complied with:

- The magnetron or other microwave generator must be connected properly.
- All input and output connections, waveguides, flanges and seals must be sealed correctly.
- A microwave oven must never be operated without a microwave load.
- Never look into an open waveguide or antenna when the appliance is on.
- **In order to ensure that no microwave energy can escape after any repair work has been completed, the appliance must be thoroughly checked for microwave leaks in accordance with all applicable local and national regulations. (In Germany, VDE regulation 0700 and CEE regulation 335 apply.)**
- Checks should be carried out using a suitable microwave leak detector in accordance with the manufacturer's instructions. Particular care should be taken around the door, casing edges, and visible vents.
- The maximum permissible value is 5 mW/cm^2 , measured at a distance of 5 centimeters (2 inches) from the appliance with a water load of $275 \text{ cm}^3 \pm 15 \text{ cm}^3$.

Technical Information

4 Precautions to Be Observed Before and During Service Work to Avoid Possible Exposure to Excessive Microwave Energy

- Do not operate or allow the oven to be operated with the door open.
- Make the following safety checks on all ovens to be serviced before activating the magnetron or other microwave source, and make repairs as necessary:
 - Interlock operation
 - Proper door closing
 - Seal and sealing surfaces (arcing, wear, and other damage)
 - Damage to or loosening of hinges and latches
 - Evidence of dropping or abuse
- Before turning on microwave power for any service test or inspection within the microwave-generating compartments, check the magnetron, wave guide or transmission line, and cavity for proper alignment, integrity, and connections.
- Any defective or maladjusted components in the interlock, monitor, door seal, and microwave generation and transmission systems shall be repaired, replaced, or adjusted by procedures described in this manual before the oven is released to the owner.
- A microwave leakage test to verify compliance with national performance standards should be performed on each oven prior to release to the owner.

B Modification History

When?	Who?	What?
4/2/2013	Jessica Naples	Minor changes throughout
7/3/2012	Jessica Naples	Tech service bulletins added
2/13/2012	Jessica Naples	Tech service bulletins added
9/8/2011	Jessica Naples	Updated
8/25/2009	Jessica Naples	Conversion for Website
4/9/2009	Christina Lemster-Bach	Version 9
8/12/2008	Christina Lemster-Bach	Version 8
4/16/2008	Christina Lemster-Bach	Version 7
7/16/2007	Christina Lemster-Bach	Version 6
6/7/2006	Christina Lemster-Bach	Version 5
11/16/2005	Christina Lemster-Bach	Version 4
7/13/2005	Christina Lemster-Bach	Version 3
6/6/2005	Christina Lemster-Bach	Version 2
6/1/2005	Christina Lemster-Bach	Version 1

C Technical Data

Features	Model	
	H 4080 BM	H 4082/4/6/8 BM
Design	Compact oven with integrated microwave	
Dimensions		
Appliance dimensions H x W x D	17.6" x 21.5" x 21.3"	
Niche dimensions		
Height	17.6" – 17.8"	
Width	22.0" – 22.4"	
Depth	min. 21.9"	
Weight ¹	108 lbs	
Cavity material	High-grade textured steel	
Capacity	1.31 cu. ft.	
Cavity height	8.0"	
Cavity base dimensions W x D	18.1" x 15.4"	
Levels in cavity (for racks)	3	
Supervision-compatible	No	Yes
Accessories included	Roast probe	
Halogen lamp power rating	10W	
Controls		
Navitronic standard text display with touchpad controls	Yes	
Time display/Clock back-up	Yes/Yes	
Delay start/Cooking time/End	Yes/Yes/Yes	
Minute minders	2	
MW recommended output	Yes	
Recommended temperature	Yes	
Actual temperature indication	Yes (not during preheat)	
Change language	Yes	
Optical interface	Yes	
Adjustable microwave output, lowest/highest	80/1000 W at 240V, 80/850 W at 208V	
Minute + Start (quick start at maximum power for 60 sec)	Yes	

Technical Information

	H 4080 BM	H 4082/4/6/8 BM
Operating modes/functions		
Solo functions		
Bake, Bake surround	No	Yes
Convection bake		
Heater output at 240V	2100W	
Max. temperature setting	435°F (225°C)	
Broil		
Broiler output at 240V	2180W (fixed setting)	
Available broiling area	183in ²	
Auto roast	Convection mode; starts at higher temperature and then switches to the selected temperature	
Max. temperature setting	425°F (210°C)	
Convection broil	Broiler and convection fan	
Max. temperature setting	400°F (200°C)	
Combination functions		
Microwave + Convection bake plus	Microwave and convection bake times have to be set the same.	
MW + Broil	Microwave and broil times have to be set the same.	
MW + Convection broil	Microwave, broil and convection fan times have to be set the same.	
Masterchef programs	Yes	
Favorites	Yes	
Sabbath mode	Yes	
Safety		
Automatic shutoff	Yes	
Safety shutoff	Yes	
System lock while running / when not running	No/Yes	
Tip protection / Slide-out protection	Yes/Yes	
Cool front panel (max. 140°F)	Yes	
Door contact switch	Yes	
RemoteVision-compatible	No	Yes
Power connection		
Voltage	AC 208/120 V – 240/120 V	
Frequency	60Hz	
Connected load	2.2kW (240V), 1.76kW (208V)	
Fuse rating	20A	

Table C-1: US Data Sheet

¹ If installing the oven into a cabinet, make sure that the cabinet or the wall can support it.

D Component Layouts

1 Appliance Overview

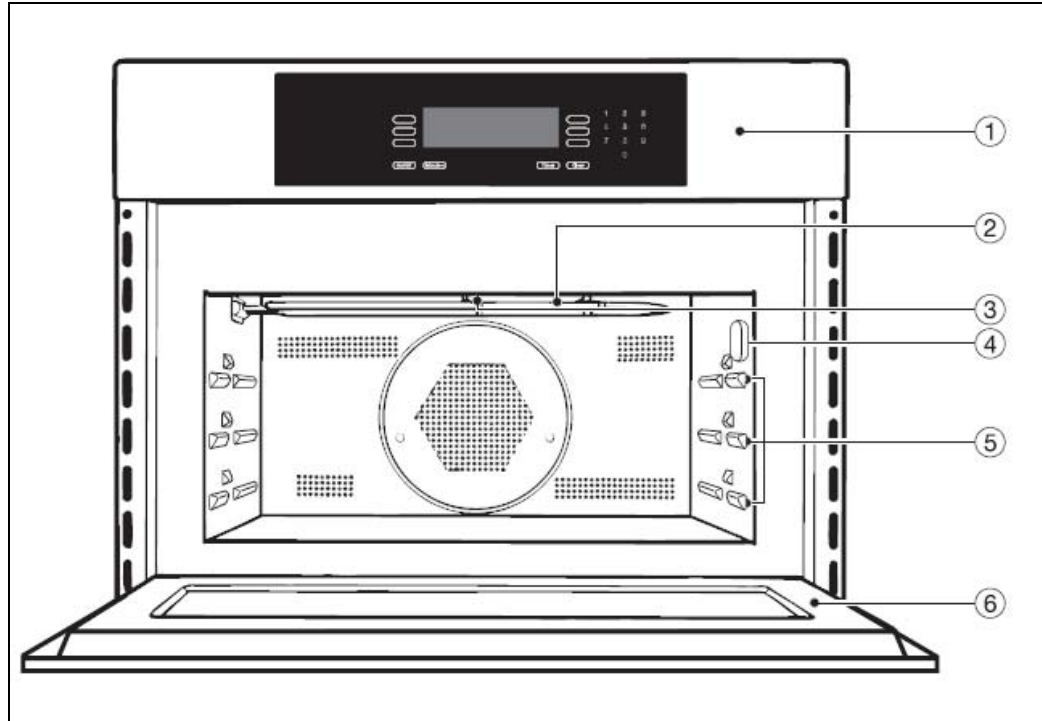
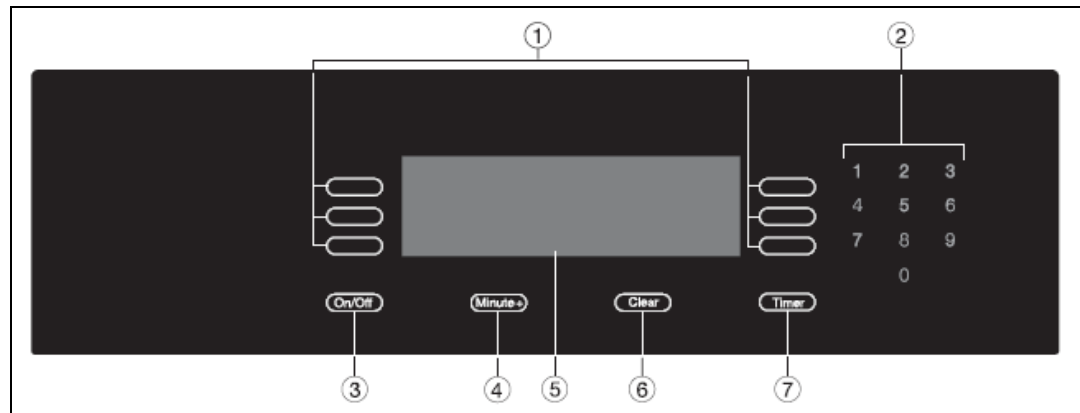

Figure D-1: Overview of Appliance (Front View)

- 1 Control panel
- 2 Upper heating element (broiler)
- 3 Light
- 4 Roast probe socket
- 5 Level runners (3)
- 6 Oven door

Technical Information

2 Overview of Controls**Figure D-2:** Overview of Controls (H 4082 BM Shown)

- 1 Menu touchpads
- 2 Numeric touchpads
- 3 **On/Off** touchpad
- 4 **Minute+** touchpad
- 5 Display
- 6 **Clear** touchpad
- 7 **Timer** touchpad

Note:

The **Clear** and **Timer** touchpads are switched on H 4080 BM models.

3 Electrical Components

3.1 H 4080 BM

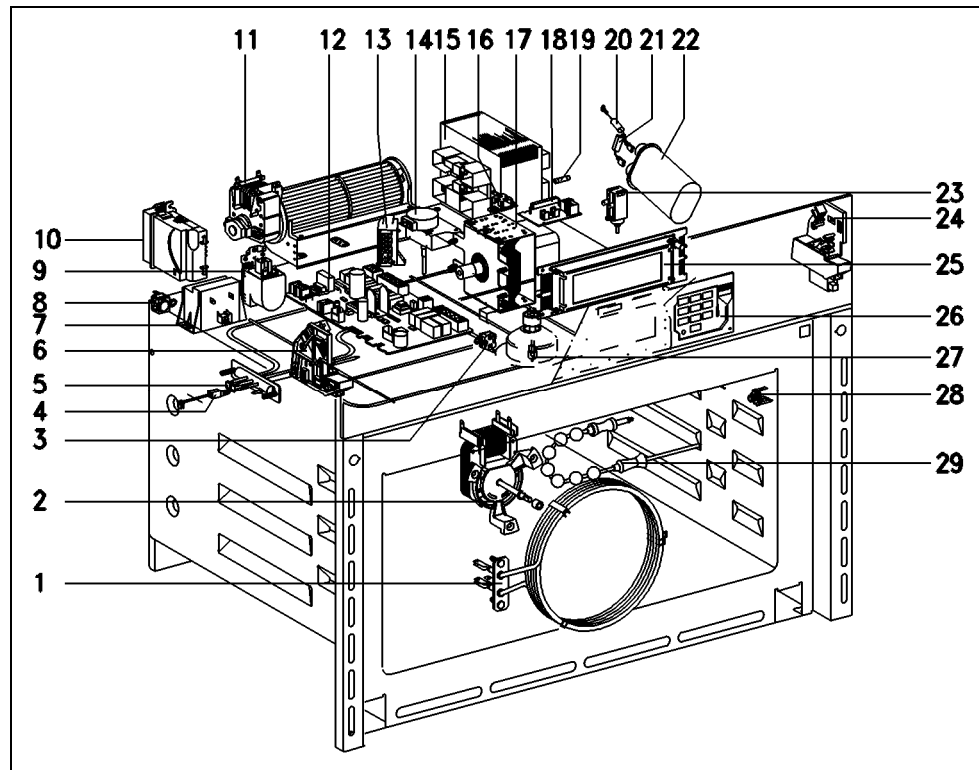

Figure D-3: H 4080 BM Component Layout

- | | |
|---|--|
| 1 (R14) Convection heater | 16 (F1/2) Magnetron thermostat (275°F) |
| 2 (M2/2) Convection fan | 17 (G2) Magnetron |
| 3 (1F1/1) Oven cavity thermostat (275°F) | 18 (3N1) Electronic EV w/drop resistor R34 |
| 4 (1R30) Oven temperature sensor (PT1000) | 19 (F8) Fine-wire fuse |
| 5 (R15) Broiler | 20 (V1) Diode |
| 6 (1F6/6), (2F6/6), (5F6/6) Left door lock with 3 safety switches | 21 (V6) Protective diode |
| 7 (2T1) Lighting transformer | 22 (A4) High-voltage capacitor |
| 8 (2F1/1) Thermostat - Fan Heat safety cutoff (248°F) | 23 (Y56) Release element |
| 9 (Z1) Interference suppression filter | 24 (3F6/6), (4F6/6) Right door lock with 2 safety switches |
| 10 (X5), (X10/1) RemoteVision socket | 25 (1A1) Control electronic (EPX) |
| 11 (M2/1) Cooling fan | 26 (2A1) Selection electronic (EW) |
| 12 (1N1) Power electronic (EPL) | 27 (1H3/2) Oven cavity light |
| 13 (K1) Safety relay | 28 (X5/8) Socket for roast probe temperature sensor |
| 14 (M21) Stirrer - wave distributor | 29 (2R30) Roast probe temperature sensor |
| 15 (1T1) High-voltage transformer | |

Technical Information

3.2 H 4082 BM and Later

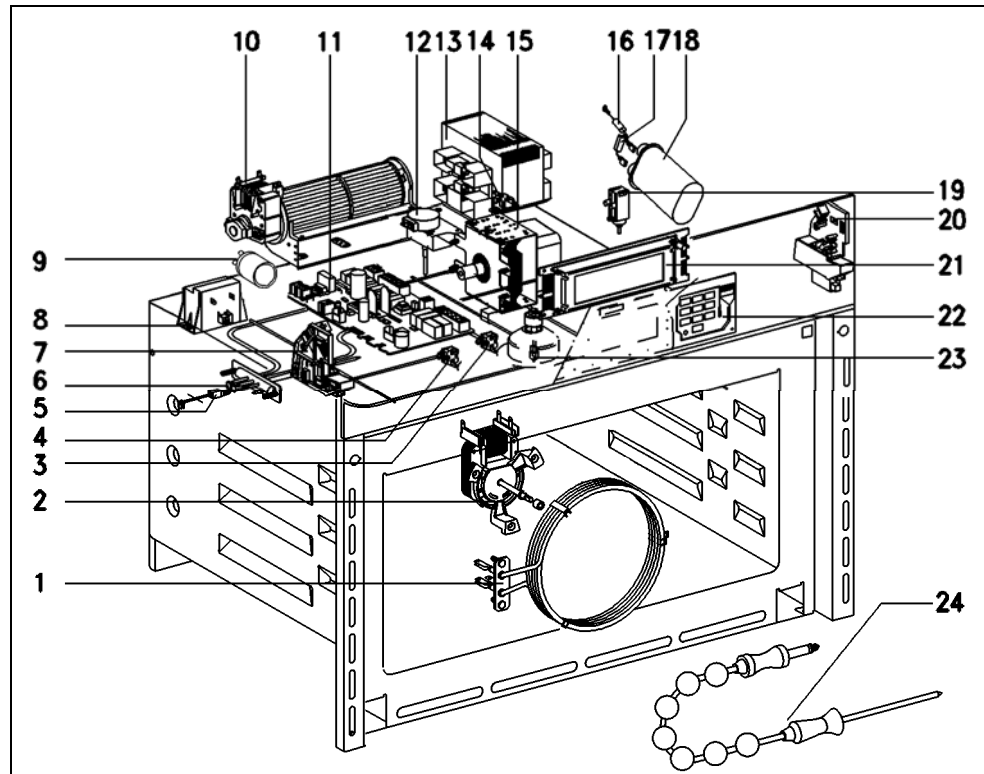
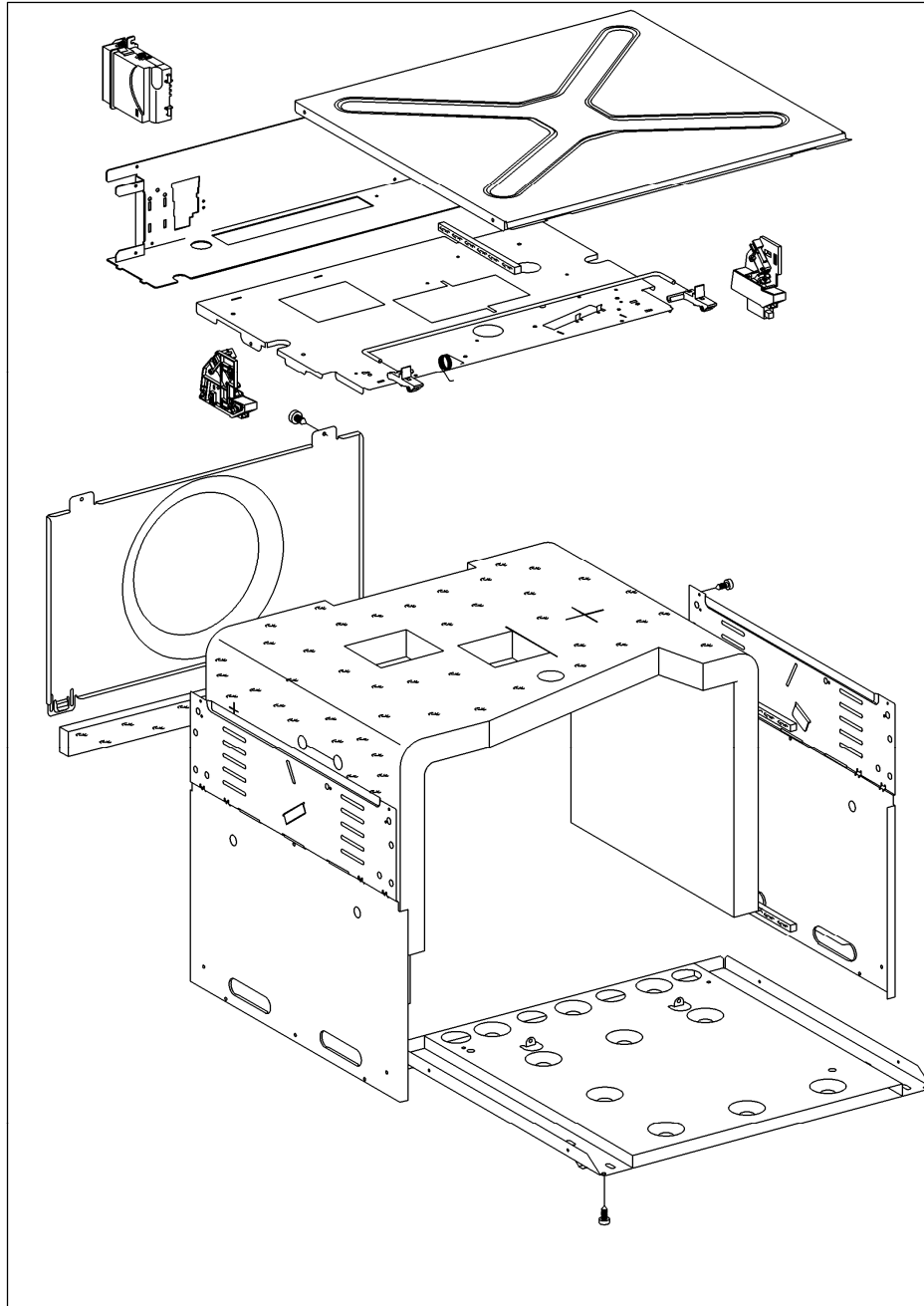

Figure D-4: Component Layout for H 4082 BM and Later

- | | |
|---|---|
| 1 (R14) Convection heater | 14 (F1/2) Magnetron thermostat (275°F) |
| 2 (M2/2) Convection fan | 15 (G2) Magnetron |
| 3 (1F1/1) Oven cavity thermostat (275°F) | 16 (V1) Diode |
| 4 (2F1/1) Thermostat - Fan Heat safety cutoff (248°F) | 17 (V6) Protective diode |
| 5 (1R30) Oven temperature sensor (PT1000) | 18 (A4) High-voltage capacitor |
| 6 (R15) Broiler | 19 (Y56) Release element |
| 7 (1F6/6), (2F6/6), (5F6/6) Left door lock with 3 safety switches | 20 (3F6/6), (4F6/6) Right door lock with 2 safety switches |
| 8 (2T1) Lighting transformer | 21 (1A1) Control electronic (EPX) |
| 9 (Z2) Interference suppression capacitor | 22 (2A1) Selection electronic (EW) |
| 10 (M2/1) Cooling fan | 23 (1H3/2) Oven cavity light |
| 11 (1N1) Power electronic (ELP) - Includes fuse F8 | 24 (2R30) Roast probe temperature sensor |
| 12 (M21) Stirrer - wave distributor | Not shown (X5/8) Socket for roast probe temperature sensor |
| 13 (1T1) High-voltage transformer | |

011 Casing, Door Lock



Technical Information

4 Service**4.1 Installation Procedure****Note:**

This appliance is designed for installation into a tall cabinet in combination with an oven, in a tall cabinet or under the countertop.

Caution!

Heating elements may be hot even though they are not glowing.

Note:

To avoid preventable damage to the appliance, follow the handling instructions attached to the top of the appliance, as shown in Figure 011-1.

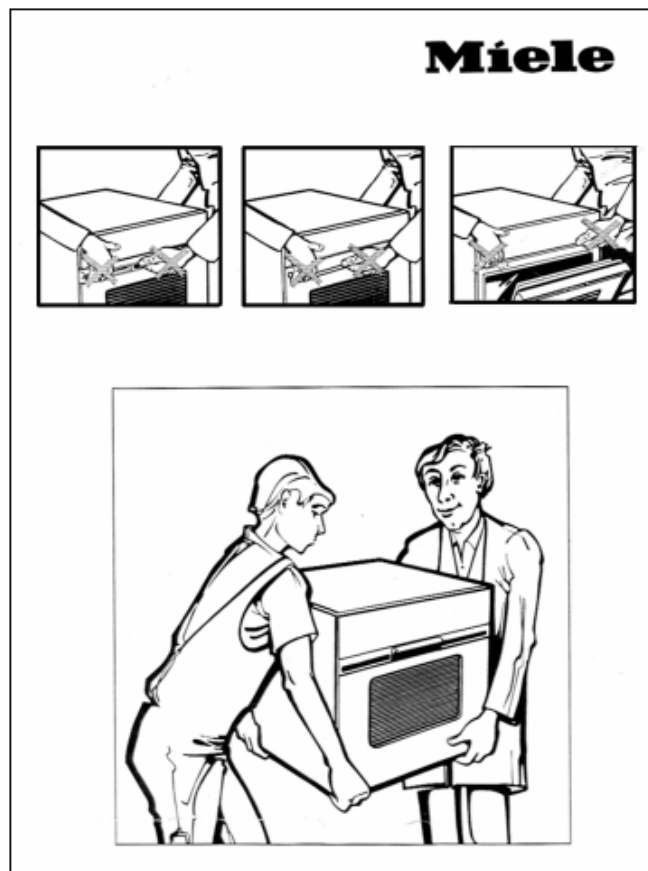

Figure 011-1: Handling Instructions Sheet (Shipped with Appliance)

1. Ensure that the supports and the opening in the cabinet allow for proper installation.
2. Ensure that the electrical supply meets the appliance requirements (see data tag on the appliance for details).

3. Remove all materials from the oven.
4. Place the oven near the cabinet opening.
5. Ensure that the power is off.
6. Connect the oven to the electrical supply.
7. Set the oven into the cabinet niche, push it all the way in, and align as necessary.
8. Open the oven door and attach the appliance to the cabinets using two retaining screws at the sides of the frame, as shown in Figure 011-2.
9. Perform "Before Using the Appliance" procedures (refer to Section 011-4.2).

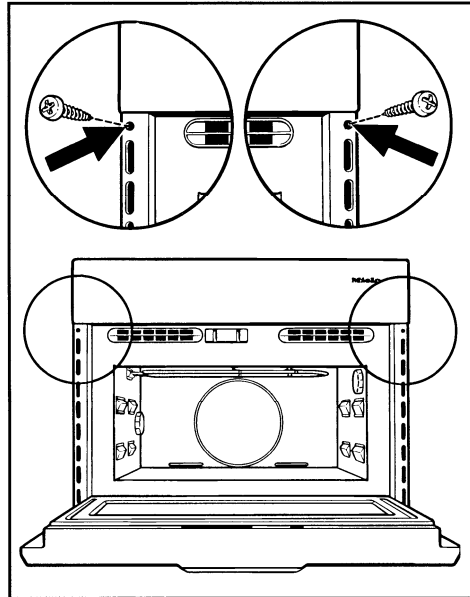

Figure 011-2: Retaining Screws

4.2 Before Using the Appliance

Note:

The following steps must be performed after performing the installation procedure (Section 011-4.1).

To ensure proper operation, the following items should be programmed appropriately for the customer's needs:

- Language
 - Time of day
 - Time format (12/24 hour format)
 - Display clock option
1. Remove the protective film from the front of the appliance (if present).
 2. Wipe the interior with a solution of warm water and liquid dishwashing detergent.
 3. Dry with a soft cloth.
 4. Leave the door open until the interior is completely dry.
 5. Close the oven door.
 6. Wash the accessories.

Technical Information**Important!**

New ovens may have a slight odor during the first use. To eliminate the odor, the oven should be operated at a high temperature for 2 hours. Before heating the oven, remove all accessories and labels from the oven and ensure that the room is well ventilated during this process.

7. Touch the **On/Off** touchpad.
8. Select the "Bake" function.
9. Select "Convection Bake".
10. Select "Temperature".
11. Set the temperature to 435 °F (225 °C) using the keypad.
12. Select "Duration".
13. Set the duration to two hours by entering "2", "0", "0" using the numeric keypad.
14. Touch the **OK** touchpad. The oven will run for 2 hours; the remaining time appears in the display.

4.3 Appliance Removal (From a Cabinet)

1. Open the door.
2. Take all items out of the oven cavity.
3. Remove the screws securing the appliance to the cabinet (see Figure 011-2).
4. Lift the appliance out of the cabinet.
5. Disconnect the power cable.

4.4 Outer Side Cover Removal

1. Remove the appliance from its cabinet; see Section 011-4.3.
2. Remove the four T20 screws securing each side cover. Remove the side covers.

4.5 Side Panel Removal

1. Remove the appliance from its cabinet; see Section 011-4.3.
2. Remove the outer side covers. See Section 011-4.4.
3. Remove the five T20 screws securing the left side panel (3 on bottom, 2 on top). Remove the left panel.
4. On the right side panel, remove the T20 screws securing the high-voltage capacitor and diode. Lay the capacitor on its side, inside the appliance, to reduce strain on the diode wires.
5. Remove the five remaining T20 screws securing the right side panel (3 on bottom, 2 on top). Remove the right panel.

4.6 Removing the Door Lock Torsion Spring

1. Remove the appliance from its cabinet; see Section 011-4.3.
2. Remove the screws securing the appliance lid. Remove the lid.

Danger!

Before performing any service or repair work, discharge the high-voltage capacitor. See Section A-2.

3. Open the door.
4. Push the door latch up and hold (Figure 011-3, Item 1).

Technical Information

5. Unhook the top arm of the torsion spring by pressing forward and down (Figure 011-3, Item 2).
6. Remove the torsion spring.

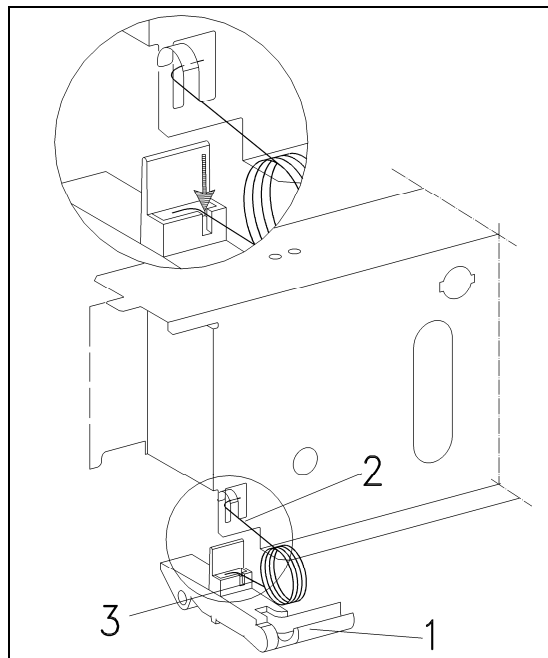

Figure 011-3: Door Lock Torsion Spring

Note: H 4082/4/6/8 BM ovens do not have the support plate shown in Figure 011-3.

Note:

When installing the torsion spring, **do not** push the latch upward. Insert the bottom arm of the torsion spring into the notch on the latch (Figure 011-3, Item 3).

Danger!

After the repair is completed, as a matter of standard practice, check the oven for a tight seal with a microwave leak detector, paying particular attention to the door and the housing edges.

4.7

Door Latch Removal

1. Remove the appliance from its cabinet; see Section 011-4.3.
2. Remove the screws securing the appliance lid. Remove the lid.

Danger!

Before performing any service or repair work, discharge the high-voltage capacitor. See Section A-2.

3. Remove the fascia panel with support plate. See Section 040-4.7.
4. Remove the door safety switches (door lock); see Section 011-4.8.
5. Remove the two screws securing the ducting front corners, if applicable (Figure 011-4, Item 1).
6. Disconnect the connectors on the magnetron thermostat.
7. Remove the two screws securing the magnetron thermostat.
8. Release the magnetron thermostat.

Technical Information

9. Slightly lift the front of the ducting (Figure 011-4, Item 3).
10. Open the appliance door.
11. Lift up the door lock and remove the latch (Figure 011-4, Item 4).

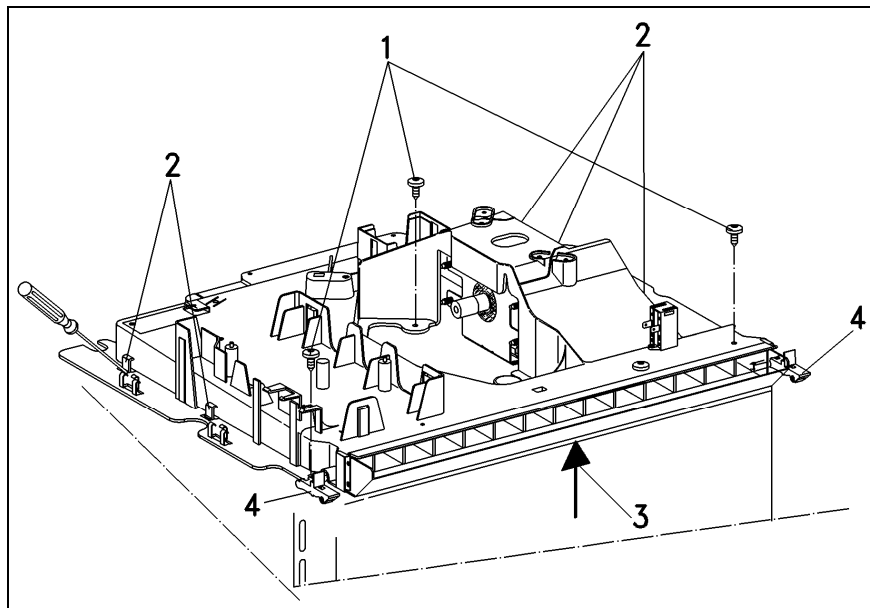
**Figure 011-4: Ducting and Door Latch**

12. Turn the wire bracket by 90°. See Figure 011-5.
13. Pull the wire bracket out of the hooks in the door latch.

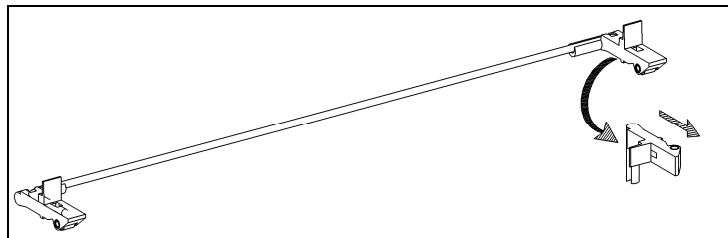
**Figure 011-5: Wire Bracket and Hooks****Danger!**

After installing the door lock, adjust the door switches. See Section 011-4.9. After installation is completed, as a matter of standard practice, check the oven for a tight seal with a microwave leak detector, paying particular attention to the door and the housing edges.

4.8**Door Lock Removal**

1. Remove the appliance from its cabinet; see Section 011-4.3
2. Remove the screws securing the appliance lid. Remove the lid.

Danger!

Before performing any service or repair work, discharge the high-voltage capacitor. See Section A-2.

Technical Information

3. Disconnect the connections to the safety switches (Figure 011-6, Item 1).
4. Insert a pointed tool into the openings in the side panel of the appliance and push in on the door lock notches (Figure 011-6, Item 2).

Note:

Should the door lock notches break off during disassembly, the door lock can be fastened again using a flat screw (mat. no. 04274261). See Figure 011-6, Item 3 (the side panel will have to be removed).

If the door lock needs to be removed again in the future, the side panel will also have to be removed again to access the screw.

5. Pull the side panel outward a few inches.
6. Push the door lock toward the back of the appliance and remove.

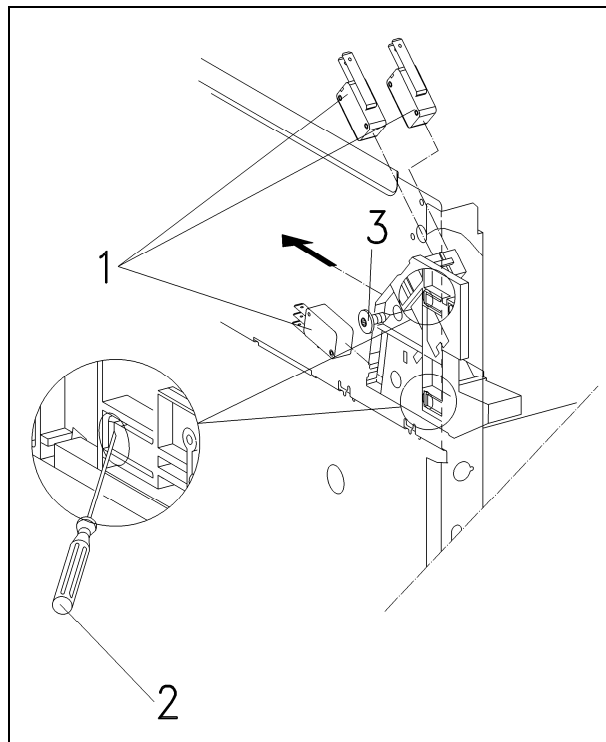

Figure 011-6: Door Lock Removal

Danger!

After installing the door lock, adjust the door switches. See Section 011-4.9. After installation is completed, as a matter of standard practice, check the oven for a tight seal with a microwave leak detector, paying particular attention to the door and the housing edges.

4.9 Door Switch Adjustment

To ensure proper function of the safety switches, the door switches have to be adjusted again after work on the door lock is completed.

Two door locks are located behind the control panel, at the left and right, with a total of five safety switches. Each door lock is equipped with a standard safety switch - 1F6/6 (left) (Figure 011-8, Item 1) and 3F6/6 (right) (Figure 011-8, Item 3) - and switched behind it a monitor switch, 2F6/6 (left) (Figure 011-8, Item 2) and 4F6/6 (right) (Figure 011-8, Item 4). Two contact pins at the upper edge activate the switches.

If the standard safety switch fails, in shut position, and the contact pins do not activate the monitor switch, current is directed via the 12-amp fine-wire fuse

Technical Information

(F8) to electronic 3N1, which then cuts out.

An additional door safety switch (5F6/6) (Figure 011-8, Item 5) is located on the left door lock and provides the electronic with the status of the position of the front door. This switch can be tested in service mode.

If a safety switch needs to be replaced, the complete door lock has to be replaced (refer to Section 011-4.8). The door safety switches cannot be replaced individually.

Note:

As a matter of standard practice, the door switches must be adjusted after completion of service or repair work on the door or the door lock. This ensures that the door can be securely locked and that any microwave leakage is within the permissible limits.

For this procedure, the complete door lock assembly must be installed.

The appliance must be disconnected from power.

Required parts:

- 3 blue magnetic shim strips, 1" x 2.8" x 0.03", mat. no. 05055650
- 3 brown magnetic shim strips, 1" x 2.8" x 0.06", mat. no. 05057340

1. Remove the appliance from its cabinet; see Section 011-4.3.
2. Remove the screws securing the appliance lid. Remove the lid.

Danger!

Before performing any service or repair work, discharge the high-voltage capacitor. See Section A-2.

3. Remove the fascia panel. See Section 040-4.5.
4. Open the door.
5. Place 3 brown magnetic strips (0.06") along the upper edge of the oven cavity (Figure 011-7, Item 1).
6. Place 3 blue magnetic strips (0.03") along the lower edge of the oven cavity (Figure 011-7, Item 2).
7. Close the door.
8. Pull the connectors off safety switches 1F6/6 and 3F6/6 (refer to Figure 011-8, Items 1 and 3).

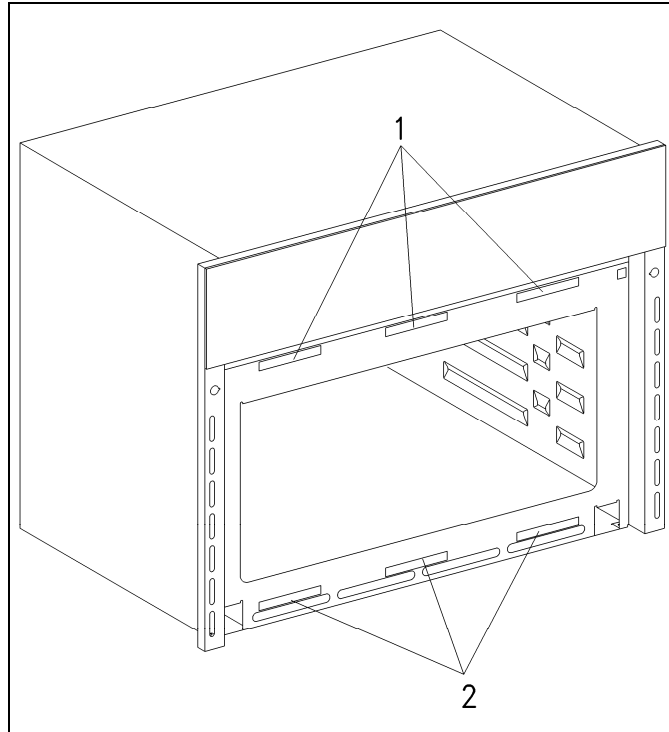

Figure 011-7: Magnetic Strips

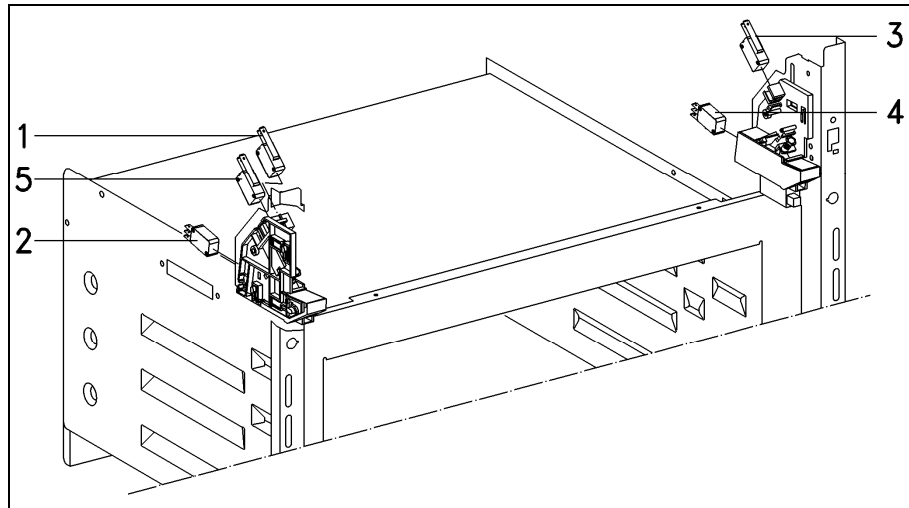

Figure 011-8: Door Safety Switches

- 1 Safety switch 1F6/6
- 2 Safety switch 2F6/6
- 3 Safety switch 3F6/6
- 4 Safety switch 4F6/6
- 5 Safety switch 5F6/6

Technical Information

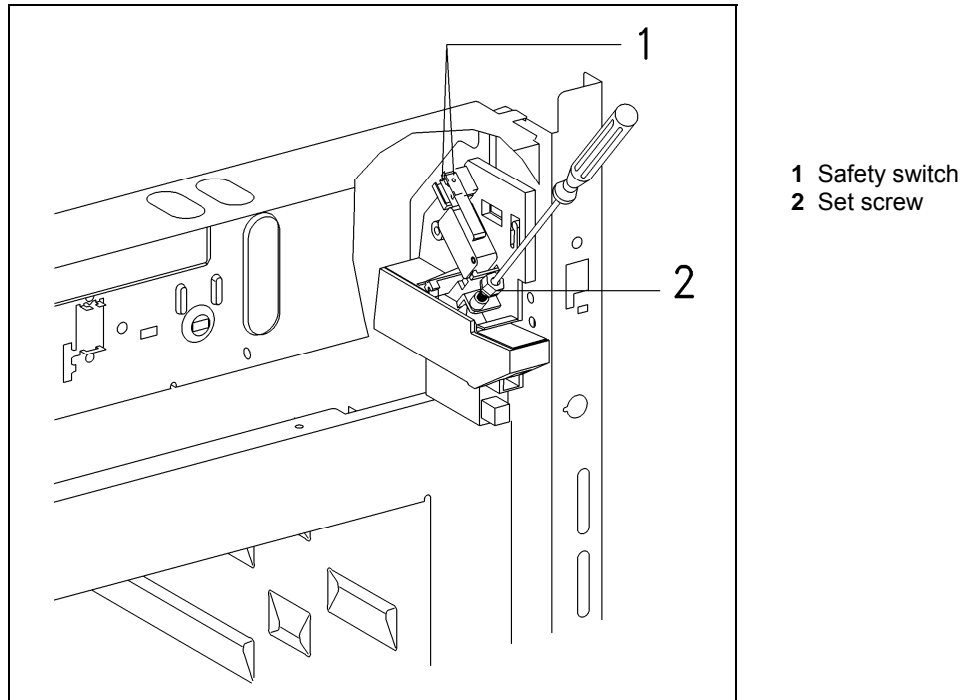

Figure 011-9: Right Safety Switch 3F6/6 and Screw

9. Test the continuity of right safety switch 3F6/6 (Figure 011-9, Item 1) using an ohmmeter. If the ohmmeter beeps, then the switch is closed.
10. Use a **metric** 8-millimeter socket wrench to turn the set screw clockwise (Figure 011-9, Item 2) until the switch opens (ohmmeter no longer beeps). Then turn the switch an additional quarter-turn.
11. Test the continuity of left safety switch 1F6/6 (Figure 011-8, Item 1) using an ohmmeter. If the ohmmeter beeps, then the switch is closed.
12. Use a **metric** 8-millimeter socket wrench to turn the set screw clockwise until the switch opens (ohmmeter no longer beeps). Then turn the switch an additional quarter-turn.
13. Open the door.
14. Remove the magnetic strips.
15. Close the door. The ohmmeter should beep (indicating continuity).

Danger!

After the procedure is completed, as a matter of standard practice, check the oven for a tight seal with a microwave leak detector, paying particular attention to the door and the housing edges.

012 Air Duct, Magnetron

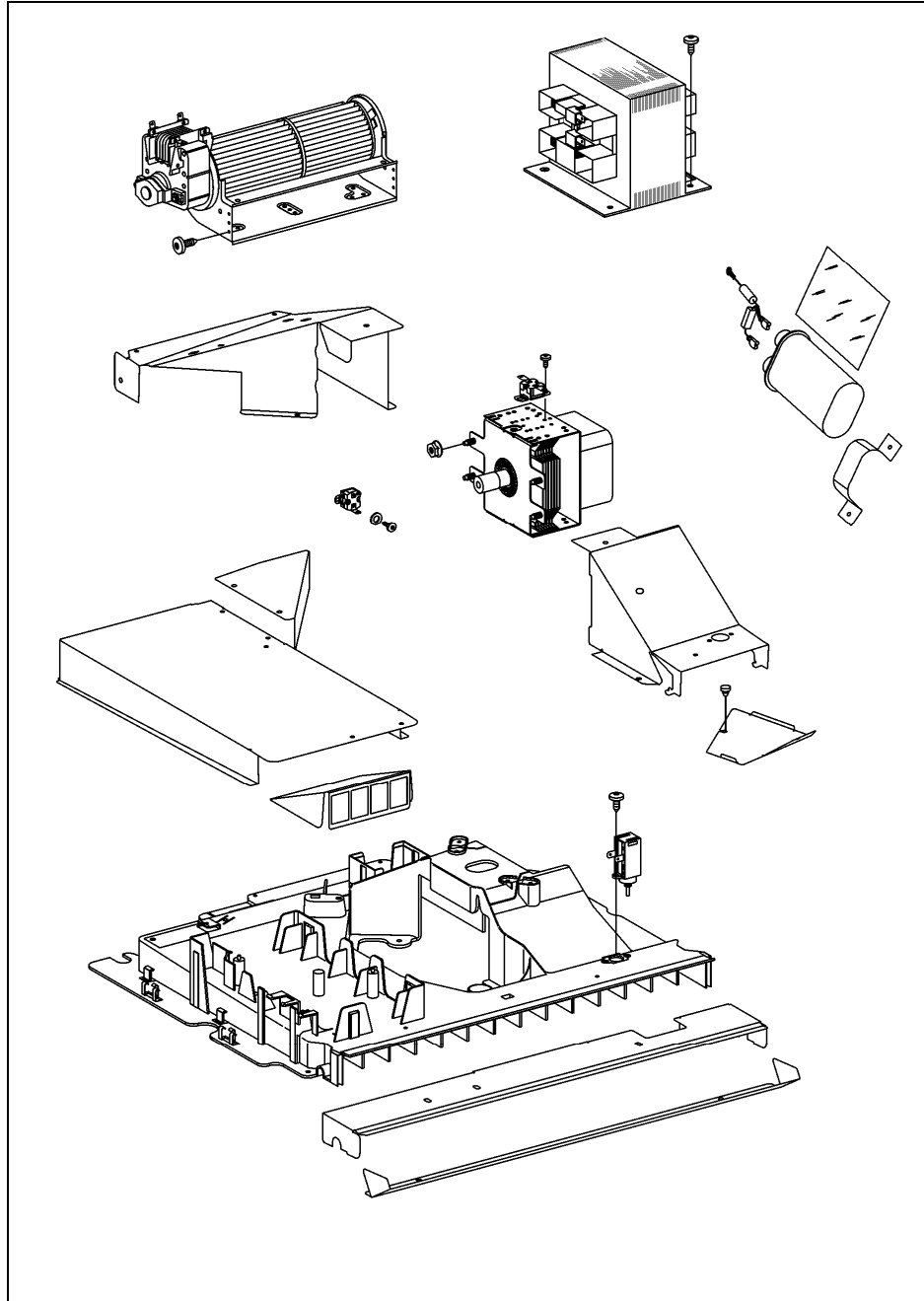

Technical Information

1 Technical Data

Cooling fan (M2/1)		
Voltage		120VAC, 60Hz
Output		51/17 W
Speed	normal	2700 rpm
	fan cooldown	1200 rpm
Switching temperature		149°F (65°C)
Magnetron (G2)		
Microwave output at 240V (partial output through pulsing)		1000W, 850W, 600W, 450W, 300W, 150W, 80W
Microwave frequency		2450MHz
Magnetron thermostat (F1/2)		
Cutoff temperature		275°F (135°C)
High-voltage capacitor (A4)		
Voltage		2100V
Capacitance		0.97µF
High-voltage transformer (T1)		
Voltage (output)		2250V (approximate)

Table 012-1: Technical Data

2 Function

2.1 Air and Vapor Ducting

1. **Cool air intake:**
The fan (Figure 012-1, Item 1) draws in cool air through the openings. The incoming air cools the appliance, the electrical components and the surrounding cabinet on all sides.
2. **Cool air and vapor path:**
The fan moves the cool air to the rear of the air duct (Figure 012-1, Item 2). The air cools the magnetron and is then moved through the front of the air duct (Figure 012-1, Item 3) where it exits the appliance.

Since machine no. 10/59114004, the multi-piece metal ducting has been replaced with a single plastic duct.
 - a. **Air path during Microwave Solo cycle:** The release element (Figure 012-1, Item 4) opens the air baffle (Figure 012-1, Item 5), permitting a small amount of cool air to enter the oven cavity, where it mixes with vapor. The air/vapor mix then moves through the vapor passage (Figure 012-1, Item 6) to the vent (Figure 012-1, Item 7) where it again mixes with cool air. If the air baffle does not open, air cannot exit and

moisture will build up in the oven cavity.

- b. **Air path during convection, broil and combination cycles:** The air baffle (Figure 012-1, Item 5) remains closed. Vapors move through the vapor passage (Figure 012-1, Item 6) into the vent (Figure 012-1, Item 7) and mix with cool air.

3. **Cool air and vapor exit:**

Cool air and vapor are pushed out through the vent above the air guide at the front of the appliance.

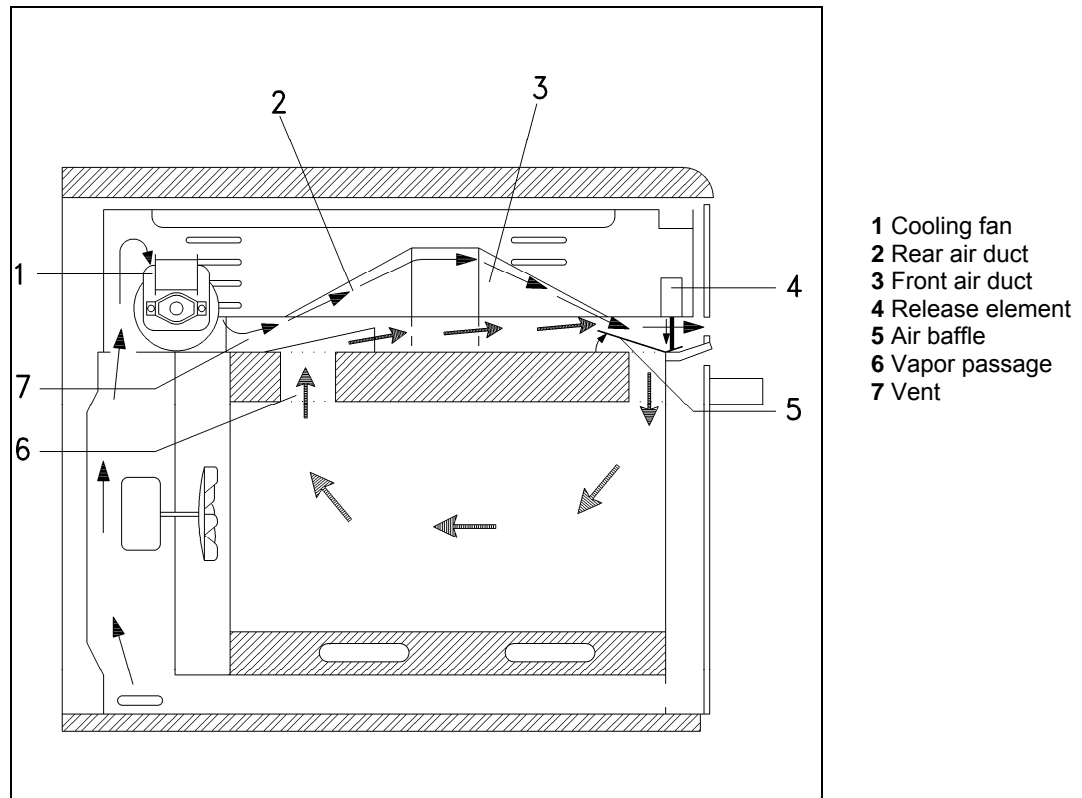

Figure 012-1: Ducting

2.2 Fan Cooldown

The cooldown function protects the appliance from damage by temperature and moisture. It is switched off when the oven cavity temperature falls below 167°F (75°C).

2.3 Microwave Operation

The high-voltage system generates the microwave energy. The incoming AC power passes through a "step-up" transformer and is further increased by the diode-rectifier circuit (including a high-voltage capacitor) to supply the magnetron with high-voltage DC power. The magnetron converts this high-voltage DC to microwaves. The microwaves pass through the wave guide and are dispersed into the oven cavity by the wave distributor motor. The oven cavity is designed to resonate the microwaves that are absorbed by the food.

Technical Information

In microwave cooking, the waves penetrate the food and excite the water and fat molecules within the food. There is no heat migrating toward the interior as heat is everywhere all at once because the molecules are excited together at the same time. This entire heating process is different than ordinary cooking, as it involves exciting atoms, rather than conducting heat.

Power Adjustment

Output power is adjusted by the control electronics varying the on-off ratio of current provided to the high-voltage transformer. The transformer output changes cycle accordingly and the magnetron is then supplied with a varying on/off cycle of high-voltage power.

Danger – High Voltage!

Even with the appliance unplugged (i.e. circuit breaker shut off), high-voltage power remains present at the following components and poses a risk of electrical shock:

- High-voltage transformer (T1)
- High-voltage capacitor (A4)
- Diode (V1)
- Protective diode (V6)
- Magnetron (G2)

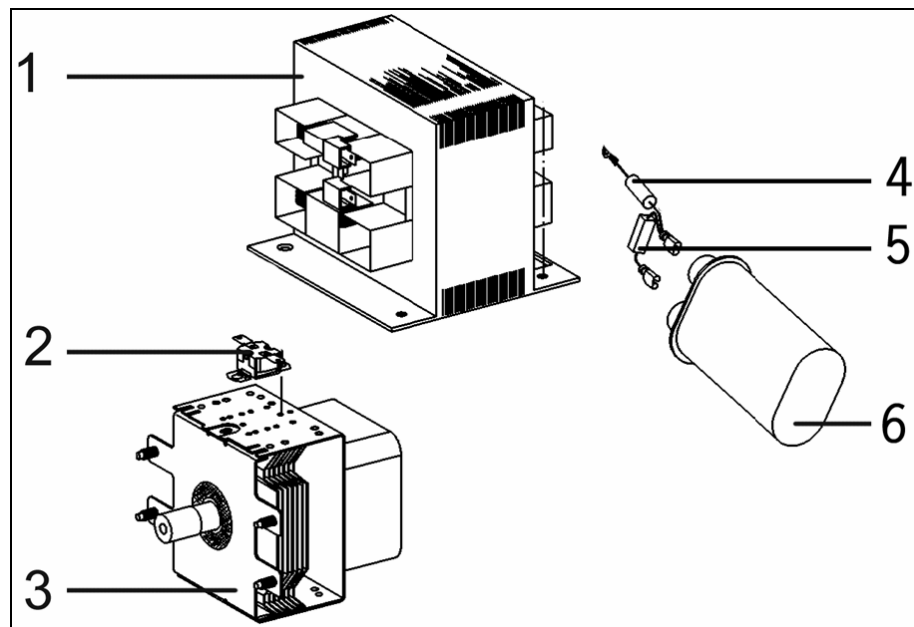

Figure 012-2: Magnetron and High-Voltage Components

- 1 High-voltage transformer (T1)
- 2 Magnetron thermostat (F1/2)
- 3 Magnetron (G2)
- 4 Diode (V1)
- 5 Protective diode (V6)
- 6 High-voltage capacitor (A4) (w/ internal resistor)

Technical Information

The magnetron (Figure 012-3, Item 1) supplies microwave energy from above into the oven cavity. A wave guide (Figure 012-3, Item 2) driven by a motor (Figure 012-3, Item 3) distributes the microwave energy.

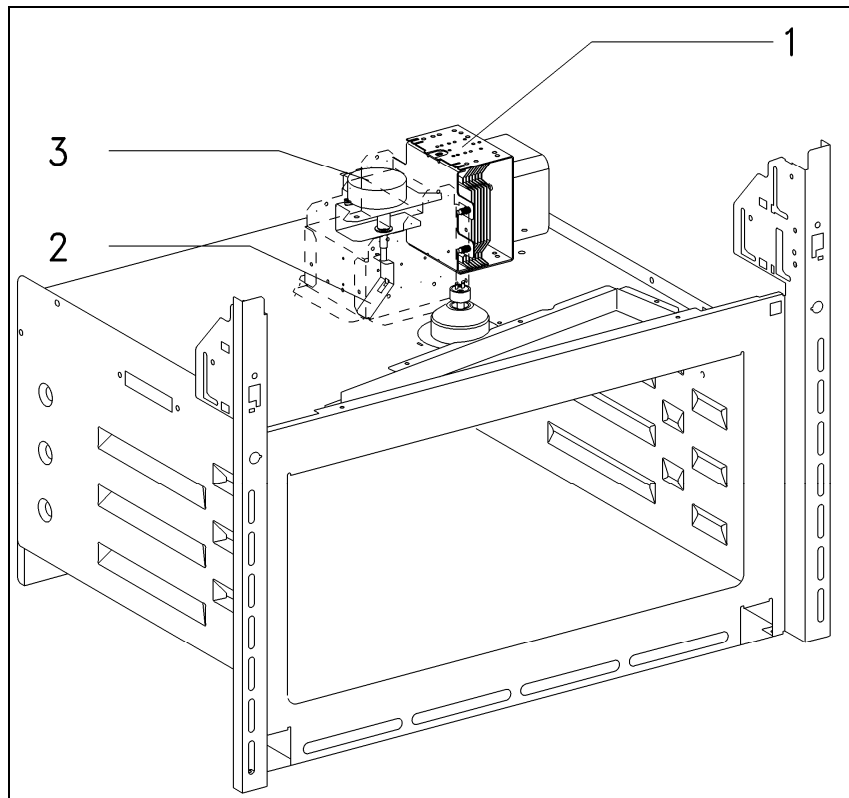

Figure 012-3: Microwave Components

4 Service

4.1 Front Air Duct Removal (up to Machine No. 10/59114003)

1. Remove the appliance from its cabinet; see Section 011-4.3.
2. Remove the screws securing the appliance lid. Remove the lid.

Danger!

Before performing any service or repair work, discharge the high-voltage capacitor. See Section A-2.

3. Remove the fascia panel. See Section 040-4.5.
4. Remove the door spring. See Section 011-4.6.
5. Remove the support plate. See Section 040-4.7.
6. Remove the screws securing the release element (Figure 012-4, Item 1).
7. Remove the release element (Figure 012-4, Item 2).
8. Remove the screws securing the air duct panel (Figure 012-4, Item 3).
9. Remove the air duct panel (Figure 012-4, Item 4).
10. Disconnect the magnetron connections (Figure 012-4, Item 5).
11. Remove the screws securing the front air duct (Figure 012-4, Item 6).
12. Remove the front air duct (Figure 012-4, Item 7).

Technical Information

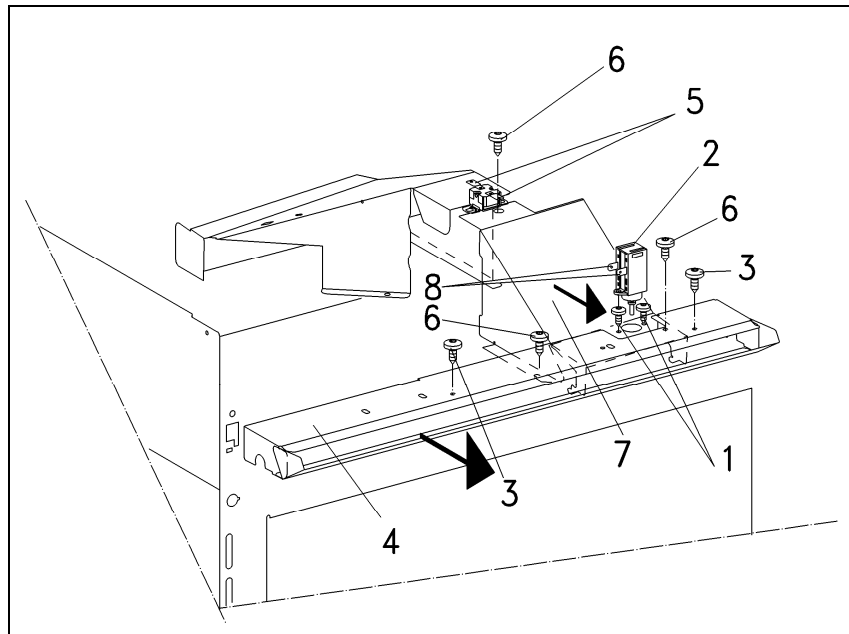

Figure 012-4: Front Air Duct Removal

Note:

When installing the front air duct, make sure that the air baffle below it can move freely.

Danger!

After installation is completed, as a matter of standard practice, check the oven for a tight seal with a microwave leak detector, paying particular attention to the door and the housing edges.

4.2

Rear Air Duct with Cooling Fan (M2/1) Removal (up to Machine No. 10/59114003)

1. Remove the appliance from its cabinet; see Section 011-4.3.
2. Remove the screws securing the appliance lid. Remove the lid.

Danger!

Before performing any service or repair work, discharge the high-voltage capacitor. See Section A-2.

3. Remove the EV790 electronic module (3N1) (Figure 012-5, Item 1).
4. Remove the safety relay.
5. Disconnect the magnetron connections (Figure 012-5, Item 2).
6. Disconnect the high-voltage transformer connections (Figure 012-5, Item 3).
7. Disconnect the cooling fan connections (Figure 012-5, Item 4).
8. Remove the screws securing the rear air duct (Figure 012-5, Item 5).
9. Remove the rear air duct with cooling fan.

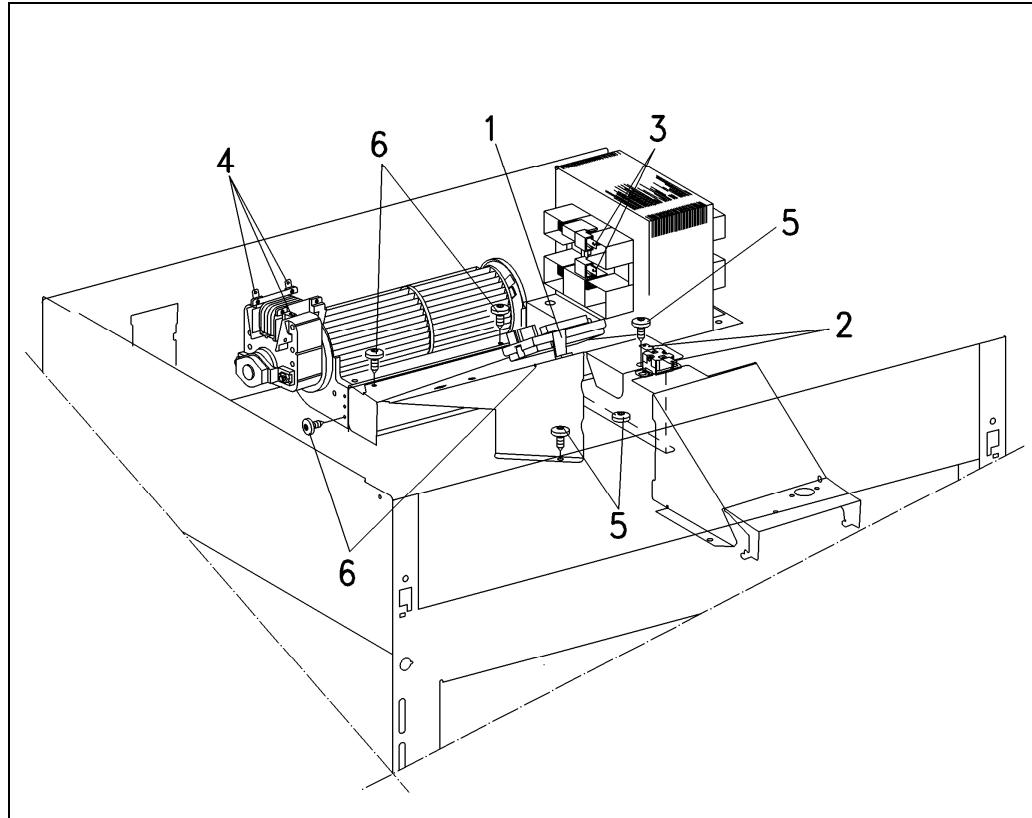

Figure 012-5: Rear Air Duct Removal

Danger!

After installation is completed, as a matter of standard practice, check the oven for a tight seal with a microwave leak detector, paying particular attention to the door and the housing edges.

4.3

Air Duct Removal (after Machine No. 10/59114004)

1. Remove the appliance from its cabinet; see Section 011-4.3.
2. Remove the screws securing the appliance lid. Remove the lid.

Danger!

Before performing any service or repair work, discharge the high-voltage capacitor. See Section A-2.

3. Remove the fascia panel with support plate. See Section 040-4.6.
4. Disconnect the magnetron thermostat connections (Figure 012-6, Item 1).
5. Remove the screws securing the magnetron thermostat (Figure 012-6, Item 2).
6. Remove the magnetron thermostat (Figure 012-6, Item 3).
7. Disconnect the cooling fan connections (3 wires and 1 Molex).
8. See Figure 012-6, Item 4.
9. Remove the screws securing the cooling fan (Figure 012-6, Item 5).
10. Remove the cooling fan (Figure 012-6, Item 6).

Technical Information

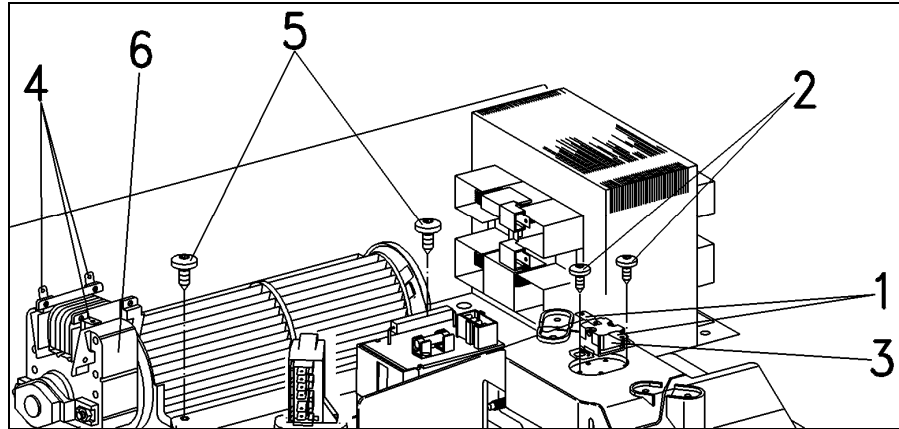
**Figure 012-6:** Air Duct Removal, Step 1

11. Remove the four T20 screws securing the air duct (Figure 012-7, Item 1).
12. Push in on the air duct retaining notches (Figure 012-7, Item 2).
13. Disconnect the electrical connections to all components on the ducting.
14. Remove the air duct (Figure 012-7, Item 3).

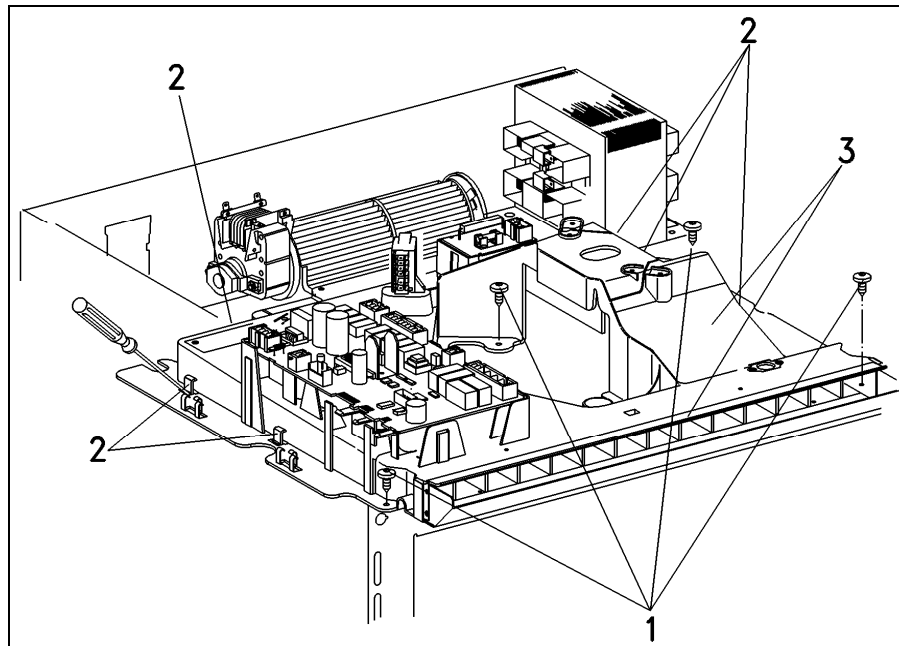
**Figure 012-7:** Air Duct Removal, Step 2

Note: When installing the air duct, make sure that the air baffle below it can move freely.

Danger!

After installation is completed, as a matter of standard practice, check the oven for a tight seal with a microwave leak detector, paying particular attention to the door and the housing edges.

4.4 Removing the Release Element (Y56)

1. Remove the appliance from its cabinet; see Section 011-4.3.
2. Remove the screws securing the appliance lid. Remove the lid.

Danger!

Before performing any service or repair work, discharge the high-voltage capacitor. See Section A-2.

3. Disconnect the release element connections (Figure 012-8, Item 1).
4. Remove the screws securing the release element (Figure 012-8, Item 2).
5. Remove the release element (Figure 012-8, Item 3).

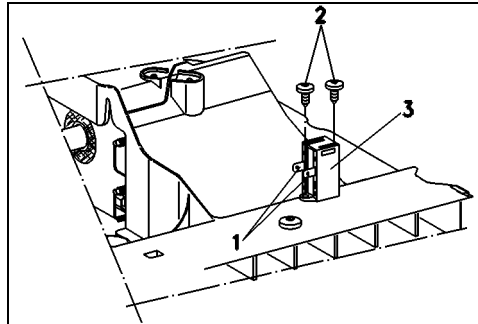

Figure 012-8: Release Element Removal

Danger!

After installation is completed, as a matter of standard practice, check the oven for a tight seal with a microwave leak detector, paying particular attention to the door and the housing edges.

4.5 Cooling Fan (M2/1) Removal (up to Machine No. 10/59114003)

1. Remove the appliance from its cabinet; see Section 011-4.3.
2. Remove the screws securing the appliance lid. Remove the lid.

Danger!

Before performing any service or repair work, discharge the high-voltage capacitor. See Section A-2.

3. Remove the rear air duct with cooling fan. See Section 012-4.2.
4. Remove the screws securing the cooling fan (Figure 012-5, Item 6).
5. Remove the cooling fan.

Danger!

After installation is completed, as a matter of standard practice, check the oven for a tight seal with a microwave leak detector, paying particular attention to the door and the housing edges.

Technical Information**4.6 Cooling Fan (M2/1) Removal (after Machine No. 10/59114004)**

1. Remove the appliance from its cabinet; see Section 011-4.3.
2. Remove the screws securing the appliance lid. Remove the lid.

Danger!

Before performing any service or repair work, discharge the high-voltage capacitor. See Section A-2.

3. Remove the screws securing the cooling fan (Figure 012-9, Item 1).
4. Disconnect the cooling fan connections (Figure 012-9, Item 2).
5. Remove the cooling fan.

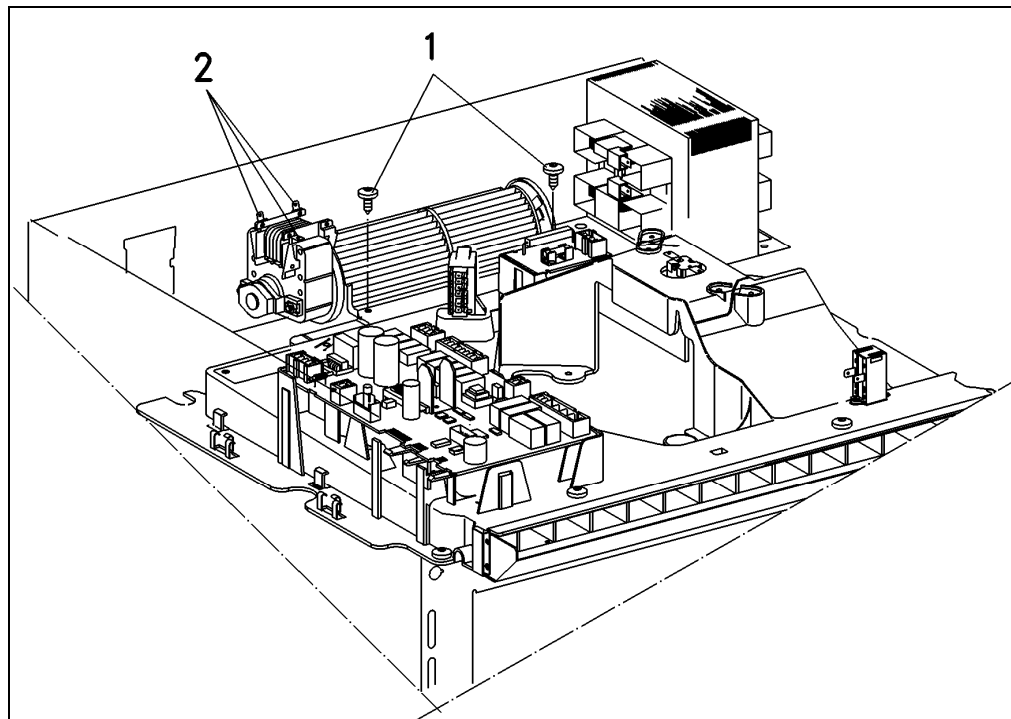

Figure 012-9: Cooling Fan Removal

Danger!

After installation is completed, as a matter of standard practice, check the oven for a tight seal with a microwave leak detector, paying particular attention to the door and the housing edges.

4.7 Testing the Magnetron (G2) Filament

1. Remove the appliance from its cabinet; see Section 011-4.3.
2. Remove the screws securing the appliance lid. Remove the lid.

Danger!

Before performing any service or repair work, discharge the high-voltage capacitor. See Section A-2.

3. Disconnect both magnetron connections.
4. Using an ohmmeter (per IEC 61010-1), measure the resistance between

Technical Information

the two terminals of the magnetron (filament). The ohmmeter has to be able to measure in the milliohm ($m\Omega$) range, and the reading must be less than one ohm (1Ω).

Danger!

After installation is completed, as a matter of standard practice, check the oven for a tight seal with a microwave leak detector, paying particular attention to the door and the housing edges.

4.8 Magnetron Test

1. Remove the appliance from its cabinet; see Section 011-4.3.
2. Remove the screws securing the appliance lid. Remove the lid.

Danger!

Before performing any service or repair work, discharge the high-voltage capacitor. See Section A-2.

3. Disconnect both magnetron connections.
4. Using an ohmmeter (per IEC 6557-2) with a measuring capability of at least 500 volts, measure the resistance between one of the two terminals and the metal housing of the magnetron.
5. The reading must be infinite ∞ .
6. Repeat the check for the second terminal.

Danger!

After installation is completed, as a matter of standard practice, check the oven for a tight seal with a microwave leak detector, paying particular attention to the door and the housing edges.

4.9 Magnetron (G2) Removal

1. Remove the appliance from its cabinet; see Section 011-4.3.
2. Remove the screws securing the appliance lid. Remove the lid.

Danger!

Before performing any service or repair work, discharge the high-voltage capacitor. See Section A-2.

3. Disconnect the magnetron thermostat connections (Figure 012-6, Item 1).
4. Remove the screws securing the magnetron thermostat (Figure 012-6, Item 2).
5. Remove the magnetron thermostat (Figure 012-6, Item 3).
6. Disconnect the cooling fan connections (3 wires and 1 Molex). See Figure 012-6, Item 4.
7. Remove the screws securing the cooling fan (Figure 012-6, Item 5).
8. Remove the cooling fan (Figure 012-6, Item 6).
9. Remove the four T20 screws securing the air duct (Figure 012-7, Item 1).
10. Push in on the air duct retaining notches (Figure 012-7, Item 2).
11. Lift the air duct upwards to release it.
12. Remove the four 8mm locknuts securing the magnetron (Figure 012-10).
13. Cut the ducting covering the magnetron at the score marks.
14. Pull the magnetron out of the wave distributor housing.

Technical Information

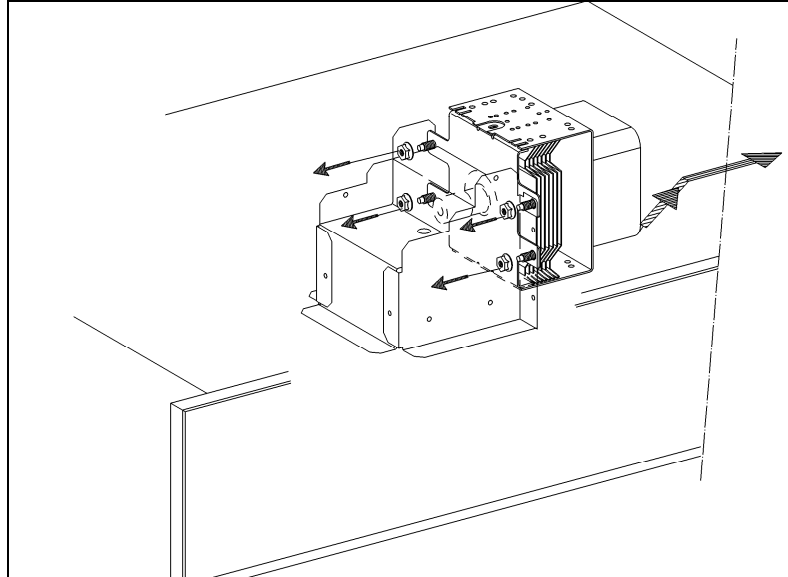
**Figure 012-10: Magnetron Removal****Note:**

When re-installing the magnetron, tighten the four locknuts securely to ensure a good ground connection. Also re-install the ducting that was removed and secure it in place.

Danger!

After installation is completed, as a matter of standard practice, check the oven for a tight seal with a microwave leak detector, paying particular attention to the door and the housing edges.

4.10 Removing High-Voltage Capacitor A4

1. Remove the appliance from its cabinet; see Section 011-4.3.
2. Remove the screws securing the appliance lid. Remove the lid.

Danger!

Before performing any service or repair work, discharge the high-voltage capacitor. See Section A-2.

3. Remove the capacitor retaining screw.
4. Remove the capacitor from the clasp assembly.
5. Disconnect the capacitor connections.
6. Pull the foil cover off the capacitor.

Danger!

Replace the foil cover between the side wall and capacitor when installing the high-voltage capacitor.

Danger!
 After installation is completed, as a matter of standard practice, check the oven for a tight seal with a microwave leak detector, paying particular attention to the door and the housing edges.

4.11 Microwave Output Test

1. Fill a heat-proof glass container (e.g., a teacup) with 4 ounces of water.
2. Use a thermometer to measure the initial temperature (T_A).
3. The temperature should be between 50°F and 68°F.
4. Put a glass baking bowl on the lowest rack of the oven.
5. Set the glass cup in the middle of the bowl.
6. Heat the water at maximum output (1000 watts) for 60 seconds.
7. Carefully stir the water.
8. Use a thermometer to measure the final water temperature (T_E).
9. If the increase in temperature ($T_E - T_A$) is at least 110°F or 120°F, the microwave output is in order.

4.12 High-Voltage Transformer Test

1. Remove the appliance from its cabinet; see Section 011-4.3.
2. Remove the screws securing the appliance lid. Remove the lid.

Danger!
 Before performing any service or repair work, discharge the high-voltage capacitor. See Section A-2.

3. Disconnect both primary connections from the transformer.
4. Use an ohmmeter to perform the following checks:

Check #	Test Point (first meter lead position)	Test Point (second meter lead position)	Reading	Status
1	A	B	0.5 to 1 Ω	OK
2	C	D	0.2 to 0.6 Ω	OK
3	E (ground)	F	40 to 60 Ω	OK

Table 012-2: High-Voltage Transformer Checks

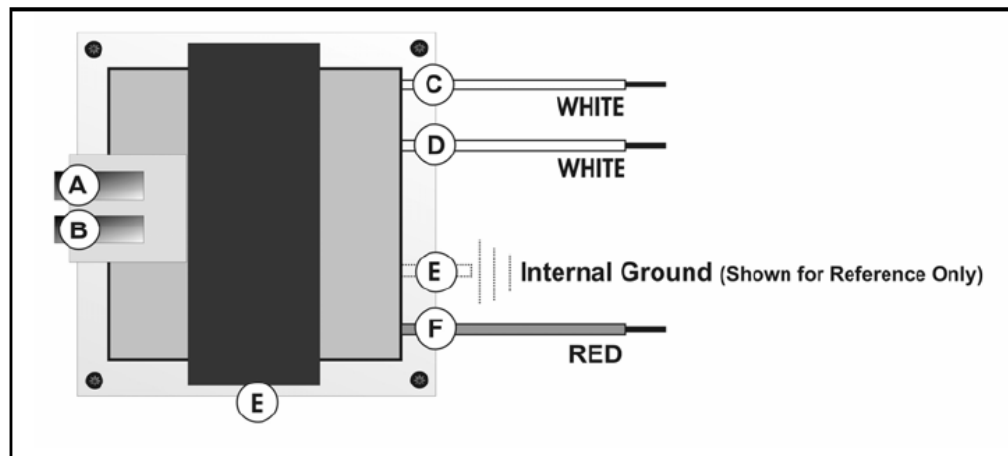

Figure 012-11: High-Voltage Transformer with Test Points Marked

Technical Information

Danger!

After installation/repair is completed, as a matter of standard practice, the appliance has to be checked for a tight seal with a microwave leak detector, paying particular attention to the door and the housing edges.

4.13 Transformer (1T1) Removal

1. Remove the appliance from its cabinet; see Section 011-4.3.
2. Remove the screws securing the appliance lid. Remove the lid.

Danger!

Before performing any service or repair work, discharge the high-voltage capacitor. See Section A-2.

3. Remove the transformer retaining screws.
4. Disconnect all connections from the transformer.
5. Disconnect connections between the transformer and the high-voltage capacitor.

Note:

When re-installing the transformer, tighten the retaining screws securely to ensure a good ground connection.

Danger!

After installation/repair is completed, as a matter of standard practice, the appliance has to be checked for a tight seal with a microwave leak detector, paying particular attention to the door and the housing edges.

4.14 High-Voltage Capacitor Test

1. Remove the appliance from its cabinet; see Section 011-4.3.
2. Remove the screws securing the appliance lid. Remove the lid.

Danger!

Before performing any service or repair work, discharge the high-voltage capacitor. See Section A-2.

3. Pull both connectors off the high-voltage capacitor.
4. Use a multimeter to measure the capacitance between the two terminals. Compare with the capacitance stated on the data plate.
5. **Or:** Use the highest range of an ohmmeter to measure the resistance between the two terminals of the capacitor.
6. The reading must start at zero ohms and go up to about 10 megaohms.
7. Reverse the positions of the measuring points. The result must be the same.

Danger!

After installation/repair is completed, as a matter of standard practice, the appliance has to be checked for a tight seal with a microwave leak detector, paying particular attention to the door and the housing edges.

Technical Information

4.15 Checking High-Voltage Capacitor A4 for Grounding

1. Remove the appliance from its cabinet; see Section 011-4.3.
2. Remove the screws securing the appliance lid. Remove the lid.

Danger!

Before performing any service or repair work, discharge the high-voltage capacitor. See Section A-2.

3. Pull both connectors off the high-voltage capacitor.
4. Measure the resistance between one terminal and the metal housing of the capacitor. This measured value must be infinite ∞ .
5. Repeat the measurement for the second terminal.

Danger!

After installation/repair is completed, as a matter of standard practice, the appliance has to be checked for a tight seal with a microwave leak detector, paying particular attention to the door and the housing edges.

4.16 Diode V1 Test

1. Remove the appliance from its cabinet; see Section 011-4.3.
2. Remove the screws securing the appliance lid. Remove the lid.

Danger!

Before performing any service or repair work, discharge the high-voltage capacitor. See Section A-2.

3. Remove the diode (assembly) from the appliance.
4. Connect the V1 diode in series on the positive lead between a 9-volt battery and a voltmeter, as shown in Figure 012-12, Item A. A properly functioning diode should provide a voltage of about 4.5 to 6.5 volts DC (depending on the condition of the battery).
5. Reverse the position of the diode. Connect the V1 diode in series on the positive lead between a 9-volt battery and a voltmeter, as shown in Figure 012-12, Item B. A properly functioning diode should not allow voltage to pass through the circuit when placed in this position. The voltmeter should display 0.

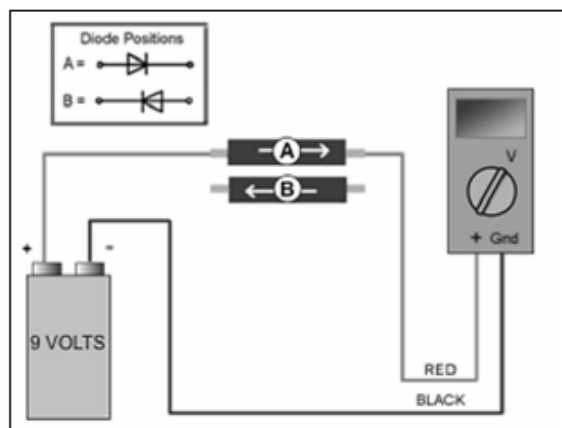

Figure 012-12: Diode V1 Test Circuit

Danger!

After installation/repair is completed, as a matter of standard practice, the appliance has to be checked for a tight seal with a microwave leak detector, paying particular attention to the door and the housing edges.

Technical Information**4.17 Checking Protective Diode V6**

1. Remove the appliance from its cabinet; see Section 011-4.3.
2. Remove the screws securing the appliance lid. Remove the lid.

Danger!

Before performing any service or repair work, discharge the high-voltage capacitor. See Section A-2.

3. Pull both connectors off the protective diode.
4. Use an ohmmeter with at least 500 volts of measuring capacity to measure the resistance between the leads in both directions.
5. The reading should be infinite ∞ in both directions.

Danger!

After installation/repair is completed, as a matter of standard practice, the appliance has to be checked for a tight seal with a microwave leak detector, paying particular attention to the door and the housing edges.

4.18 No Microwave Power – Diagnosis Procedure

The following procedure should be used in the event that an H 408x BM speed oven is reported as “the microwave function is not working”, but other aspects of the appliance are in functioning order.

This procedure will quickly isolate the fault to the appropriate circuit and/or component(s).

Caution!

Parts of this procedure are performed while the appliance is connected to live power.

Do **NOT** deviate from this procedure or skip steps unless instructed to within the procedure. Skipping steps can produce inconclusive results.

Warning!

Do **NOT** attempt to operate the microwave system at any time during this procedure.

Perform the high-voltage capacitor discharge procedure before testing any components within the high-voltage circuit. Refer to Section A-2.

Procedure overview:

Perform door switch checks (sections 4.18.1 and 4.18.2), replacing appropriate component(s) as necessary.

If ALL door switches check okay, proceed to Section 4.18.3 (as directed).

4.18.1 Door Switch 1F6 and 2F6 Test

1. Access the terminal block and verify that the appliance is being supplied with the proper electrical supply (L1, L2, neutral and ground). Ensure that live lines are on separate phases.
2. Ensure that the oven door is closed.

Technical Information

3. Check for 120VAC between ST1 (pin 2) and ST6 (pin 10) on the power electronic (1N1).
 - a. If 120VAC is present, proceed to Section 4.18.2.
 - b. If 120VAC is NOT present, proceed to step 4 below.
4. Check for 120VAC between ST1 (pin 2) on the power electronic (1N1) and ST1 (pin 3) on the fuse electronic (3N1).
 - a. If 120VAC is present, fault is within switch 1F6 and/or 2F6.
 - b. If 120VAC is NOT present, proceed to step 5 below.
5. Check for 120VAC between ST1 (pin 2) on the power electronic and ST1 (pin 4) on the EV790 fuse electronic (3N1).
 - a. If 120VAC is present, disconnect the appliance from power, replace fuse F8 on the EV790 fuse electronic (3N1) and locate the cause of fuse failure by disconnecting voltage to the appliance and performing a continuity check of all four door switches. Replace the appropriate component(s) before restoring power to the appliance.
 - b. If 120VAC is NOT present, recheck for proper supply voltage at the terminal block.

4.18.2 Door Switch 3F6 and 4F6 Test

1. Check for 240VAC between ST6 (pin 10) on the power electronic (1N1) and the input (single blue) wire on the magnetron thermostat (F1/2).
 - a. If 240VAC is present, proceed to step 2 below.
 - b. If 240VAC is NOT present, proceed to step 3 below.
2. Check for 240VAC between ST6 (pin 10) on the power electronic and the output (double blue) wire on the magnetron thermostat (F1/2).
 - a. If 240VAC is present, proceed to Section 4.18.3.
 - b. If 240VAC is NOT present, replace F1/2 (magnetron thermostat).
3. Check for 240VAC between ST6 (pin 10) on the power electronic (1N1) and L2 on the terminal block (X3/1).
 - a. If 240VAC is present, fault is within switch 3F6 and/or 4F6.
 - b. If 240VAC is NOT present, recheck for proper supply voltage at the terminal block.

4.18.3 High-Voltage Component Tests

1. Disconnect the appliance from the power (unplug/shut off circuit breaker).
2. Discharge the high-voltage capacitor. Refer to Section A-2.
3. Unplug ST6 from the power electronic (1N1) and unplug ST1 from the fuse electronic (3N1).
4. Perform a continuity check of the orange wire between connector ST6 (pin 7) and connector ST1 (pin 1) that was connected to the fuse electronic (3N1).
 - a. If continuity is present (wire is okay), proceed to step 5.
 - b. If continuity is NOT present, repair the break in the wiring.
5. Reconnect ST6 to the power electronic and ST1 to the EV790 fuse electronic (3N1).
6. Check for approximately 56 Ω across resistor R34 (R1) on the EV790 fuse electronic (3N1).
 - a. If the resistance is within reasonable range (+/- 10%), proceed to step 7.
 - b. If the resistance is NOT within range, replace the EV790 fuse electronic (including the resistor) (3N1).

Technical Information

7. Perform the high-voltage transformer test. Refer to Section 012-4.12.
8. Perform the high-voltage capacitor checks. Refer to Sections 012-4.14 and 012-4.15.
9. Perform the magnetron test procedure. Refer to Section 012-4.8.
10. Perform the V1 diode test (Section 012-4.16) and the V6 protective diode test (Section 012-4.17).
11. Reassemble the appliance.
12. Access the oven cavity, remove the ceiling cover retaining screws and ceiling cover.
13. Restore power to the appliance.
14. Briefly perform the microwave output test (Section 012-4.11) and verify that the wave distributor motor is functioning (turning).
15. If all components/test(s) check okay, perform the following:
 - a. Disconnect the appliance from power (unplug/shut off circuit breaker).
 - b. Discharge the high-voltage capacitor. See Section A-2.
 - c. Replace the power electronic.

020 Door

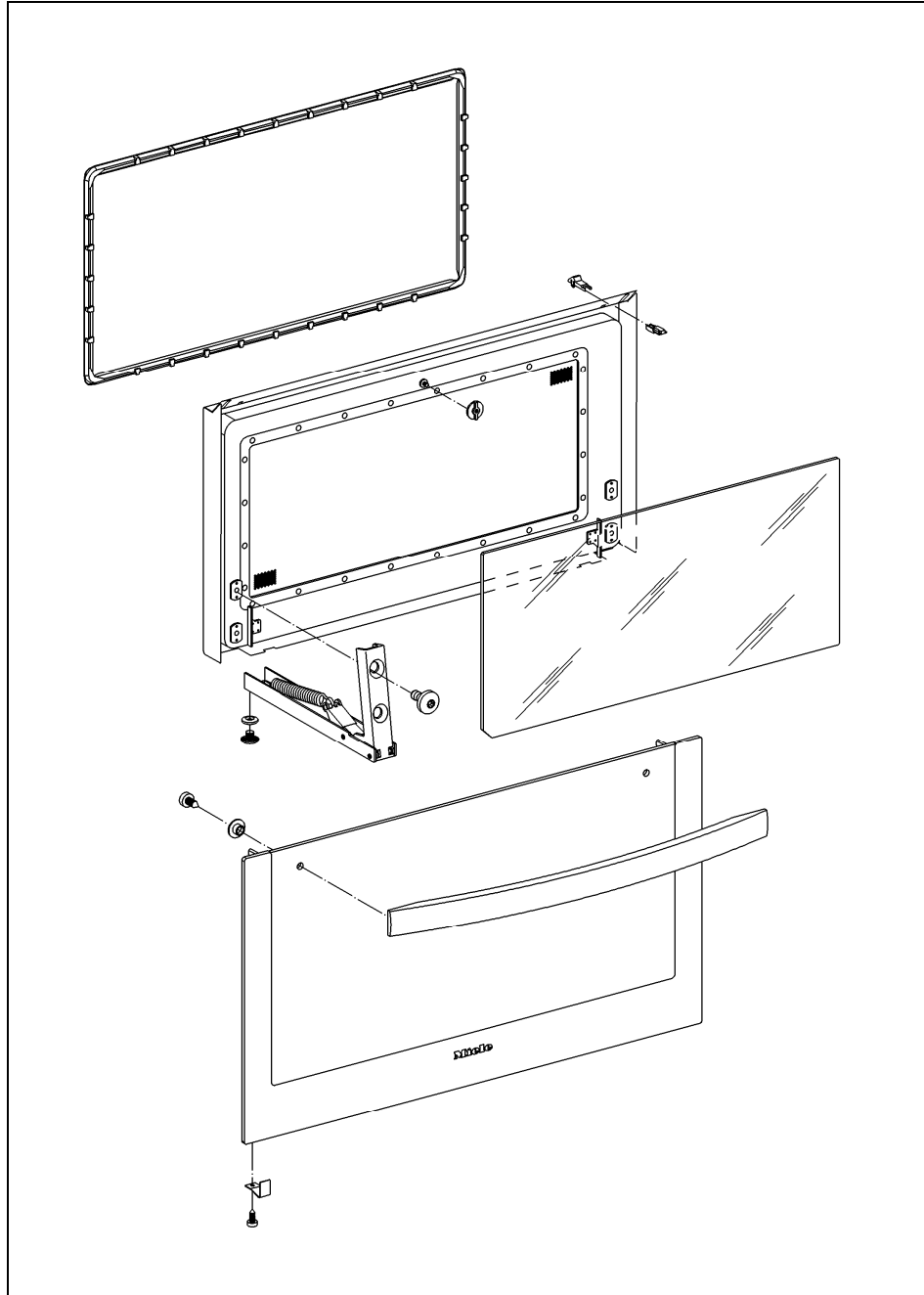

Technical Information

4 Service**4.1 Door Seal Removal**

1. Open the door.
2. Carefully, without using tools, pull the rubber door seal out of its groove.

Note:

When re-installing the door seal, pay attention to the correct placement at the corners.

4.2 Removing the Door Outer and Middle Panes

1. Open the door a few inches.
2. Using a pointed tool, push in the two silver notches on the door's upper edge until you hear it click (Figure 020-1, Item 1).
3. Tilt the outer pane a few inches forward, pulling the pins of the door contact switches from their slots (Figure 020-1, Item 2).

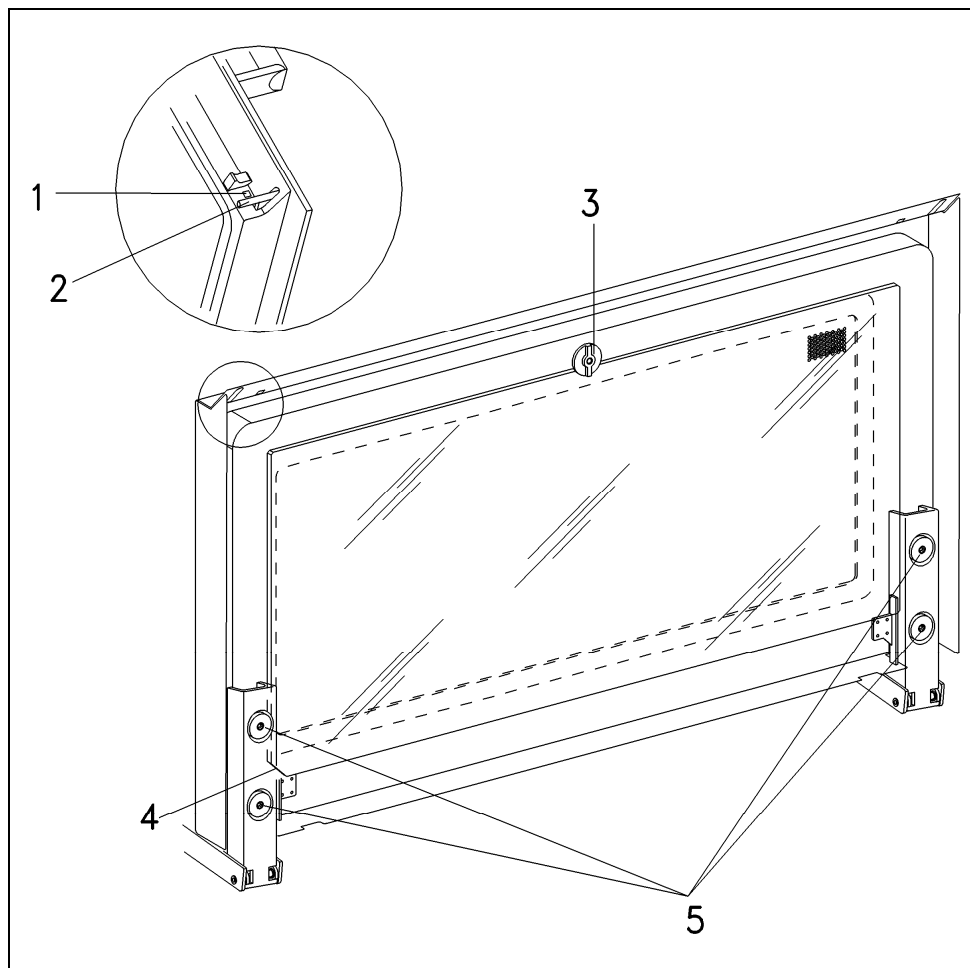

Figure 020-1: Door Pane Removal

Technical Information

Note:

When removing the outer pane, take care not to bend the metal hooks on the bottom of the door. Push them back into position if needed before re-installing the door.

4. Pull the outer pane up and remove it.
5. Remove the wing nut at the top of the middle pane (Figure 020-1, Item 3).
6. Pull the middle pane up and remove it.

Note:

When re-installing the middle pane, make sure that the beveled corner is at the lower left (see Figure 020-1, Item 4).

Note:

When re-installing the outer pane, set the bottom retaining brackets onto the pins. With both hands, firmly push on the outer pane until you hear it engage on both sides with a click.

4.3 Removing the Door Handle

1. Remove the door outer pane (refer to Section 020-4.2).
2. Place the outer pane flat onto a work surface, inner side facing up.
3. Remove the handle retaining screws.
4. Remove the handle.

4.4 Removing the Door Inner Pane**Note:**

The door inner pane is not replaceable on its own. If it is broken, then the entire door must be replaced. See Section 020-4.5.

4.5 Removing the Door, Complete with Hinges

1. Remove the appliance from its cabinet (refer to Section 011-4.3).
2. Turn the appliance on its side.
3. Remove the hinge retaining screws on the bottom of the appliance.

Note: When the door is pulled out, the hinges will snap shut.

4. Leading with the bottom edge, remove the door (with hinges) from the appliance.

Danger!

Adjust the door switches after installation (see Section 011-4.9).
After installation is completed, as a matter of standard practice, check the oven for a tight seal with a microwave leak detector, paying particular attention to the door and the housing edges.

Technical Information**4.6 Door Hinge Removal**

1. Remove the door. See Section 020-4.5.
2. Remove the screws securing the door hinges (Figure 020-2, Item 1).
3. Remove the door hinges.

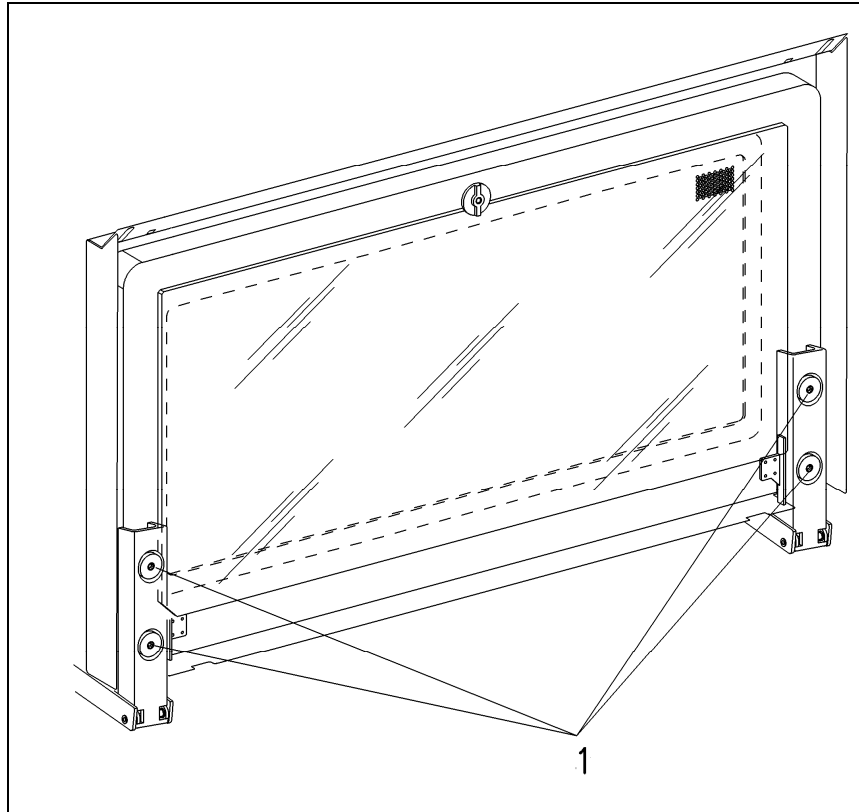
**Figure 020-2:** Door Hinge Removal**Danger!**

When installing the hinges, place 3 blue magnetic strips, 1" x 2.8" x 0.03" (mat. no. 05055650) as spacers along the lower oven cavity edge (Figure 011-7, Item 2).

After re-installation, adjust the door switches; see Section 011-4.9.

After installation is completed, as a matter of standard practice, check the oven for a tight seal with a microwave leak detector, paying particular attention to the door and the housing edges.

031 Oven Cavity, Wave Distribution

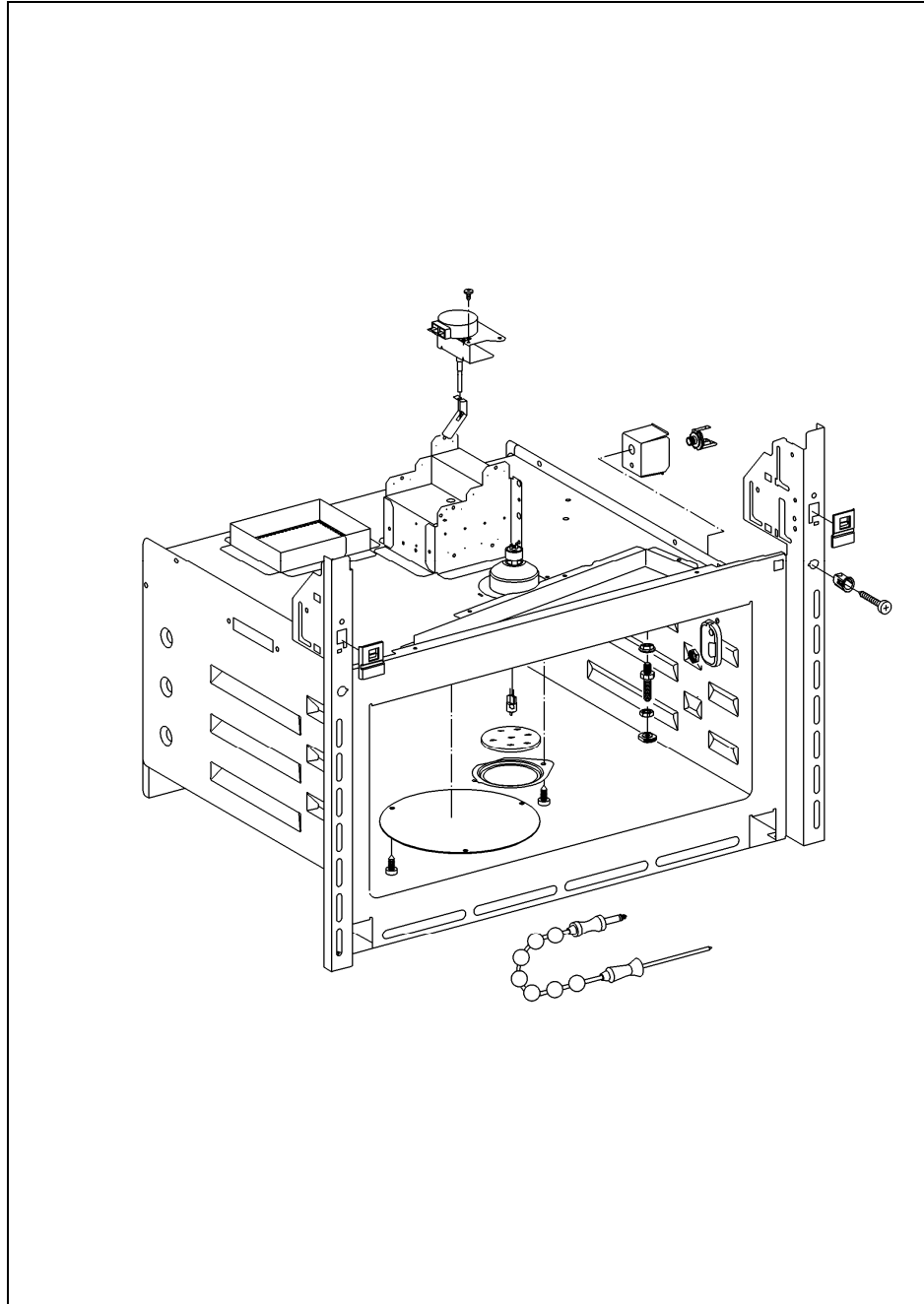

Technical Information

1 Technical Data

Wave distributor motor (M21)	
Voltage	220 – 240 VAC, 50 / 60 Hz
Output	2.5W
Speed	29.8 / 35.8 rpm
Oven cavity light (H3/2)	
Voltage	12V
Output	10W
Heat-proof	up to 572°F (300°C)

Table 031-1: Technical Data**3 Fault Repair****3.1 Iridescent Shine in Oven Cavity (H 4082 BM)****Cause:**

Not a fault! Oven cavities with PerfectClean shine differently when exposed to light.

Remedy:

None.

4 Service**4.1 Removing Wave Distributor Motor M21**

1. Remove the appliance from its cabinet (refer to Section 011-4.3).
2. Open the door.
3. Remove the thumbnut securing the broil element in the oven cavity.
4. Flip down the broil element in the oven cavity.
5. Remove the three T20 screws securing the ceiling cover (Figure 031-1, Item 1).
6. Remove the ceiling cover (Figure 031-1, Item 2).
7. Release the locking tab on the guide plate, then pull the plate down and off its shaft (see Figure 031-1, Item 3).

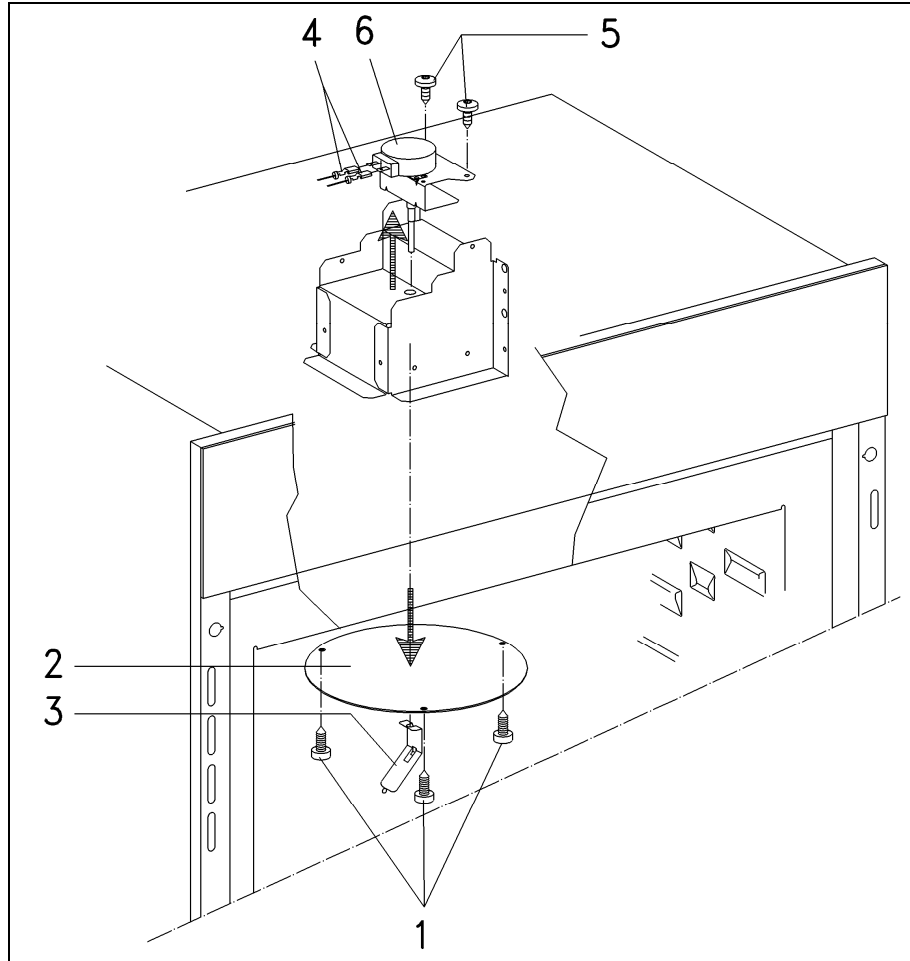

Figure 031-1: Wave Distributor Motor Removal

8. Remove the screws securing the appliance lid. Remove the lid.

Danger!

Before performing any service or repair work, discharge the high-voltage capacitor. See Section A-2.

9. Disconnect the motor connections (Figure 031-1, Item 4).

10. Remove the two T20 screws securing the motor (Figure 031-1, Item 5).

11. Remove the motor (Figure 031-1, Item 6).

Danger!

After installation is completed, as a matter of standard practice, check the oven for a tight seal with a microwave leak detector, paying particular attention to the door and the housing edges.

Technical Information**4.2 Halogen Lamp Removal**

1. Remove the bulb cover retaining screw at the top of the oven cavity.
2. Remove the bulb cover.
3. Pull the bulb out to remove.

Note:

Never touch a halogen bulb with bare fingers. When inserting a glass halogen bulb, always hold with a soft cloth.

4.3 Measuring the Temperature in the Middle of the Oven Cavity**Note:**

- Measure according to EN 60350.
- The heater elements must generate their maximum output power at nominal voltage, or else interference caused by a faulty temperature regulator is possible.
- The specified times were obtained with a supply voltage of 230 volts.
- Temperature variations were originally specified in K (Kelvin).

Note:

Required tools:

- Electronic thermometer, mat. no. 05595760
- Sensor, mat. no. 07121370
- Magnetic holder, mat. no. 05054650
- Sensor socket, mat. no. 07132940
- Oven rack

1. Check the voltage of the switched-off and switched-on heating system.
2. Hook the sensor (Figure 031-2, Item 1) in the magnetic holder (Figure 031-2, Item 3).
3. Slide a rack into the empty oven (first level from the bottom). The sensor must be located in the geometric center of the oven (Figure 031-2, Item 1).
4. Close the oven door.
5. Set up the **Quick Heatup 250°C** mode.
6. A temperature increase of 155 degrees must be reached in 5.5 minutes maximum.

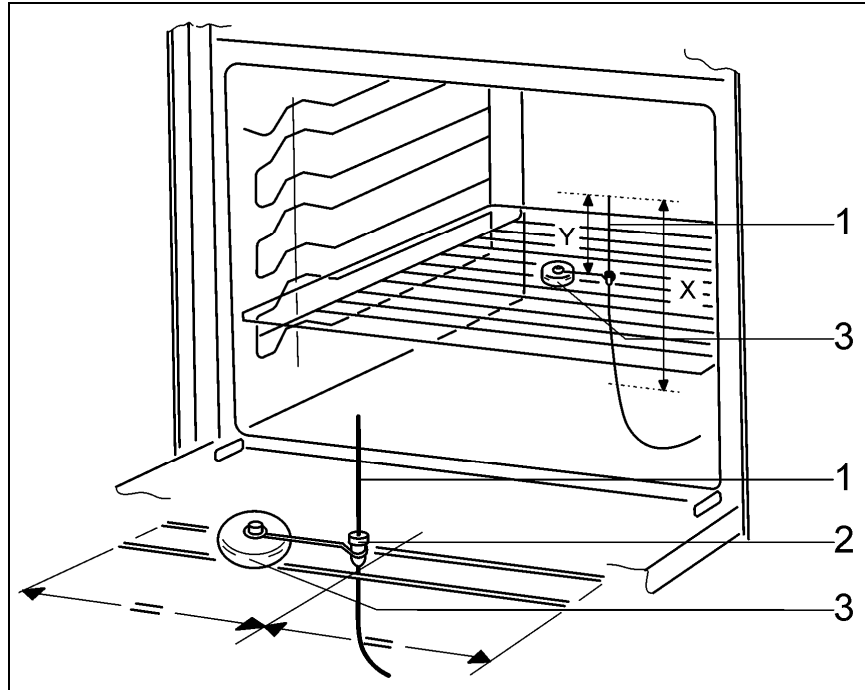
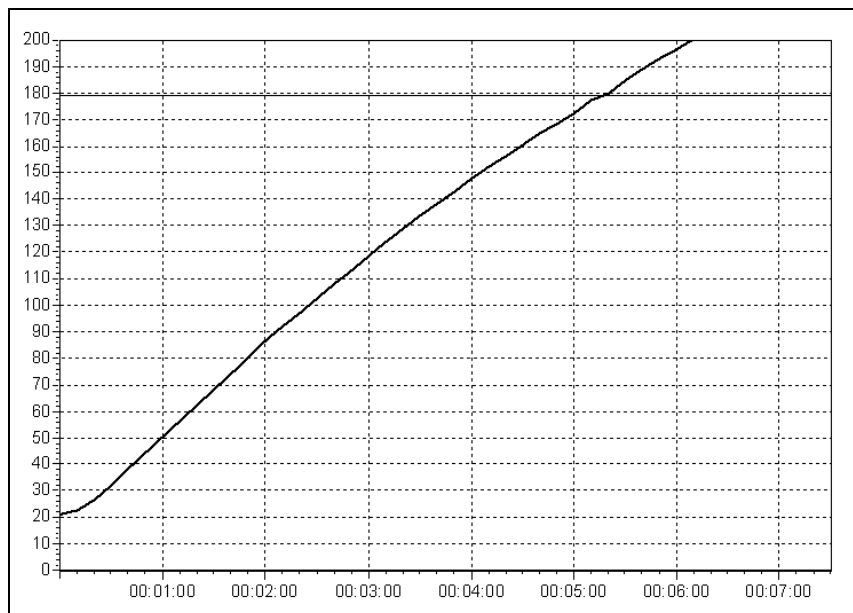

Figure 031-2: Temperature Test

- 1 Sensor
- 2 Sensor socket
- 3 Magnetic holder
- X Distance from oven cavity floor: 4" (10 cm)
- Y Distance from sensor tip to insertion: greater than 2" (5 cm)



X-axis = Time in minutes:seconds
Y-axis = Temperature in Celcius

Figure 031-3: Sample Measurement with an Ambient Temperature of 20°C (68°F)

Technical Information

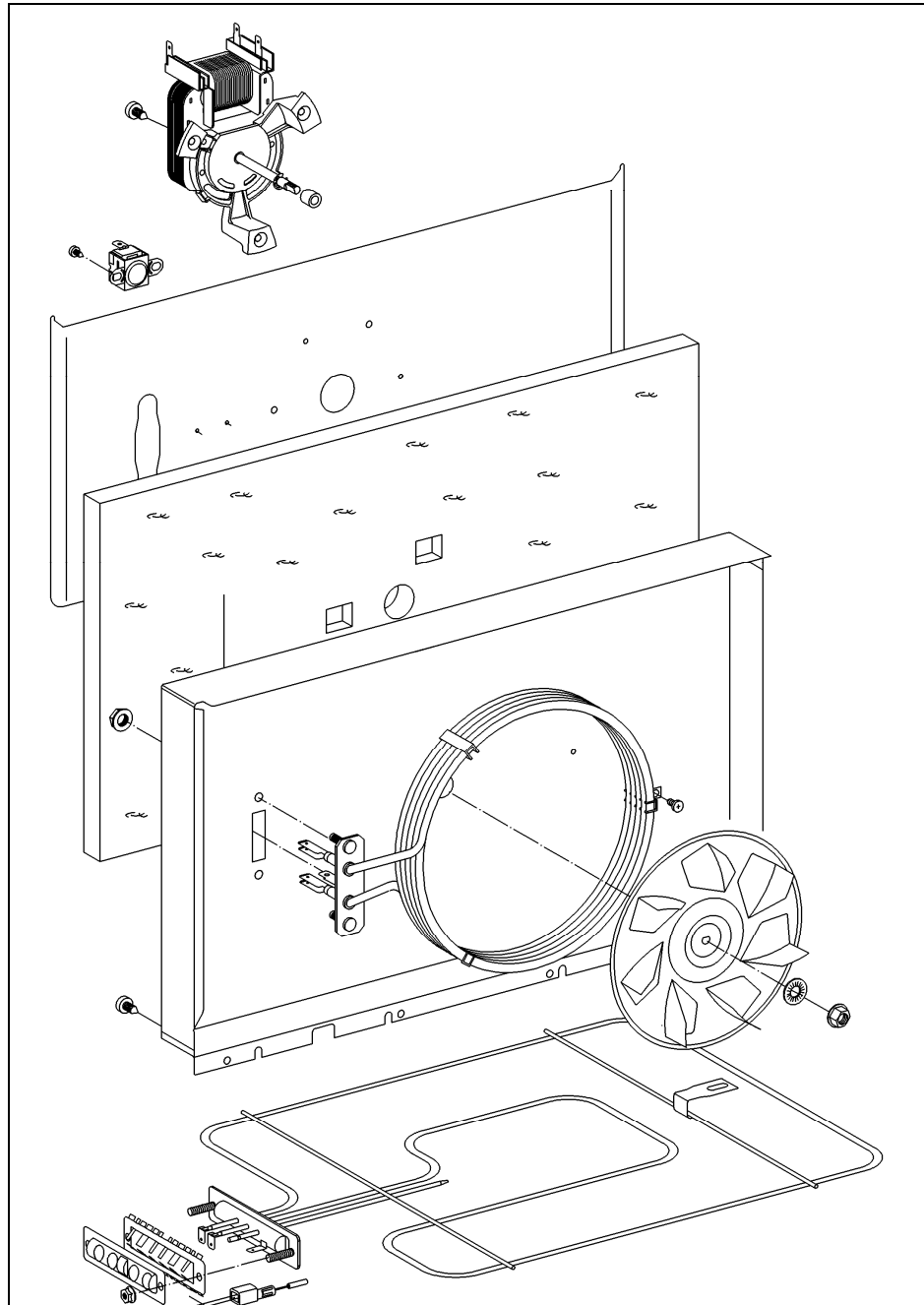
032 Convection Fan, Heaters

1 Technical Data

Convection fan (M2/2)	
Voltage	120VAC, 60Hz
Speed	2500 rpm
Convection heater element (R14)	
Voltage	220 – 240 VAC
Output at 240V	2100W
Convection thermostat (2F1/1)	
Switching temperature	248°F (120°C)
Broil heater element (R15)	
Voltage	220 – 240 VAC
Output at 240V	2180W fixed
Broil thermostat (1F1/1)	
Switching temperature	275°F (135°C)

Table 032-1: Technical Data

2 Function

2.1 Safety Cutoff

If there is an error in communication between control electronic 2N1 and power electronic 1N1, safety relay K1 is activated and relays 1 to 4 of the power electronic are cut off. Both heater elements and the magnetron are switched off via relay K1.

Thermostat 1F1/1 (275°F) at the magnetron wave guide monitors the oven cavity temperature. At excess temperatures, safety relay K1 is activated, which switches off both heaters. Because of the distance to broil heater R15, the cutoff temperature is set correspondingly low.

If convection fan M2/2 is defective, the safety cutoff of convection heater R14 is activated via thermostat 1F1/1 (248°F) at the rear of the oven cavity. Because of the distance to convection heater R14, the cutoff temperature is set correspondingly low.

2.2 Heater Element Timing

In operating modes **microwave + broil** and **microwave + convection plus**, broil heater elements R15 or convection heater elements R14 are switched in sequence and not switched on at the same time as the microwave.

Technical Information

2.3 Heater Element Switching in Operating Modes

Figure 032-1: Convection Plus, Auto Roast



Figure 032-2: Broil, Convection Broil

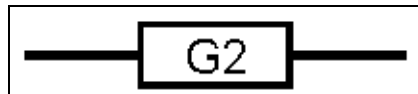

Figure 032-3: Microwave

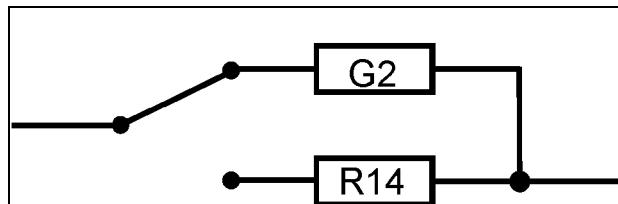

Figure 032-4: Microwave + Convection Plus, Microwave + Auto Roast (Sequential Operation)

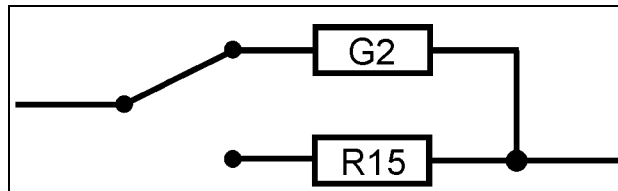

Figure 032-5: Microwave + Broil, Microwave + Convection Broil (Sequential Operation)

2.4 Convection Fan

The convection fan is mounted to the rear wall of the oven. It pressurizes a large volume of air in the small cavity located within the rear wall of the appliance to produce true convection heating.

4 Service**4.1 Fan Impeller Removal**

1. Remove the appliance from its cabinet (refer to Section 011-4.3).
2. Remove the three T20 screws securing the back wall, as well as the T20 screw securing the terminal block cover. Remove the terminal block cover and the back wall.
3. Disconnect the connections from the convection heater (Figure 032-6, Item 1), thermostat (Figure 032-6, Item 2) and convection fan (Figure 032-6, Item 3).
4. Remove the two T20 screws securing the sides of the fan rear panel (Figure 032-6, Item 4).
5. Remove the bottom insulation strip.

Technical Information

6. Remove the four T20 screws securing the bottom of the fan rear panel (Figure 032-6, Item 4).
7. Remove the fan rear panel with convection fan and convection heater.

Note: The impeller retaining nut is a left-hand thread.

8. Unscrew the nut securing the impeller.
9. Remove the impeller.

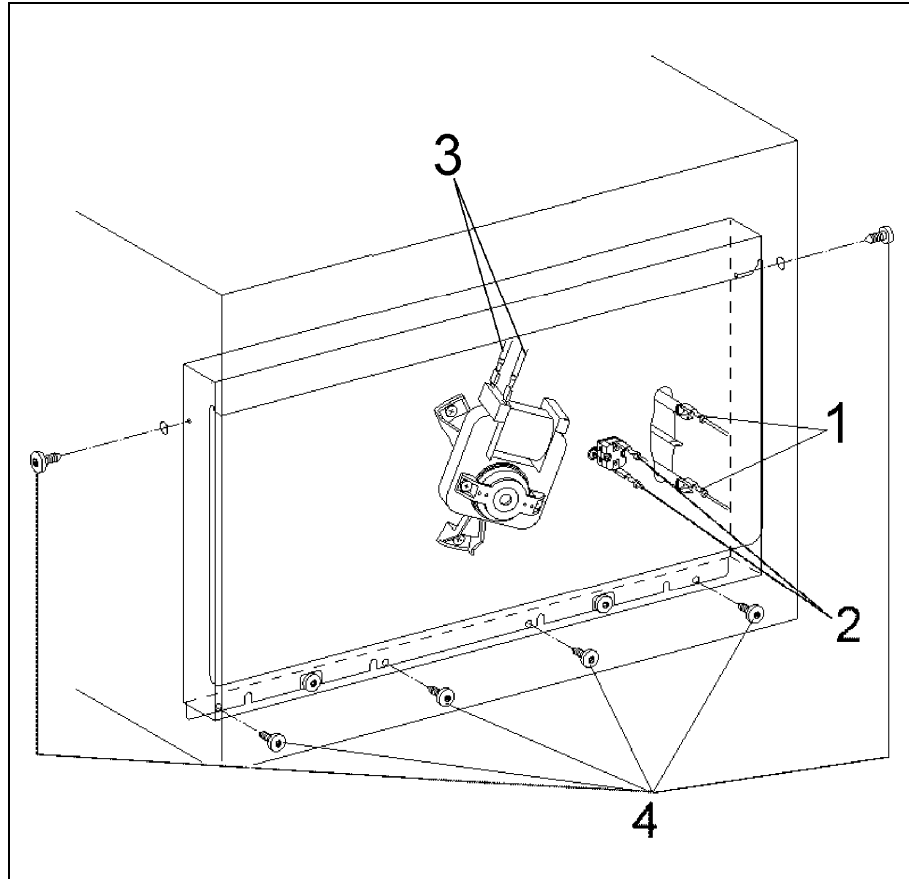

Figure 032-6: Fan Impeller Removal

Note:

After installation of the fan rear panel, replace the bottom insulation strip.

Danger!

After installation is completed, as a matter of standard practice, check the oven for a tight seal with a microwave leak detector, paying particular attention to the door and the housing edges.

4.2 Convection Fan (M2/2) Removal

1. Remove the appliance from its cabinet (refer to Section 011-4.3).
2. Remove the impeller. See Section 032-4.1.
3. Remove the convection fan retaining screws.
4. Remove the convection fan.

Technical Information**Note:**

After installation of the fan rear panel, replace the bottom insulation strip.

Danger!

After installation is completed, as a matter of standard practice, check the oven for a tight seal with a microwave leak detector, paying particular attention to the door and the housing edges.

4.3 Removing Convection Heater Element R14

1. Remove the appliance from its cabinet (refer to Section 011-4.3).
2. Remove the three T20 screws securing the back wall, as well as the T20 screw securing the terminal block cover. Remove the terminal block cover and the back wall.
3. Disconnect the connections from the convection heater (Figure 032-6, Item 1), thermostat (Figure 032-6, Item 2) and convection fan (Figure 032-6, Item 3).
4. Remove the two T20 screws securing the sides of the fan rear panel (Figure 032-6, Item 4).
5. Remove the bottom insulation strip.
6. Remove the four T20 screws securing the bottom of the fan rear panel (Figure 032-6, Item 4).
7. Remove the fan rear panel with convection fan and convection heater.
8. Unscrew the heater element retaining nuts.
9. Remove the convection heater element.

Note:

After installation of the fan rear panel, replace the bottom insulation strip.

Danger!

After installation is completed, as a matter of standard practice, check the oven for a tight seal with a microwave leak detector, paying particular attention to the door and the housing edges.

4.4 Convection Thermostat Removal

Remove the two screws securing the thermostat. Unclip the thermostat and remove it from its retaining bracket.

4.5 Removing the PT1000 Temperature Sensor (1R30)

1. Remove the appliance from its cabinet (refer to Section 011-4.3).
2. Remove the screws securing the left side of the lid.
3. Remove the screws securing the left side wall.
4. Remove the left side wall.
5. Push in on the notches of the temperature sensor retainer and gently twist it out to remove.

4.6 Removing Broil Heater Element R15

1. Remove the appliance from its cabinet (refer to Section 011-4.3).
2. Remove the screws securing the left side of the lid.
3. Remove the screws securing the left side wall.
4. Remove the left side wall.
5. Push in on the notches of the temperature sensor bracket.
6. Push in on the notches of the temperature sensor retainer and gently twist it out to remove.
7. Pull the connectors off the heater element (Figure 032-7, Item 1).
8. Unscrew the two heater element locknuts (Figure 032-7, Item 2).
9. Remove the two support plates (Figure 032-7, Item 3).
10. Unscrew the thumbnut in the oven cavity (Figure 032-7, Item 4).
11. Take the heater element out of the oven cavity (Figure 032-7, Item 5).

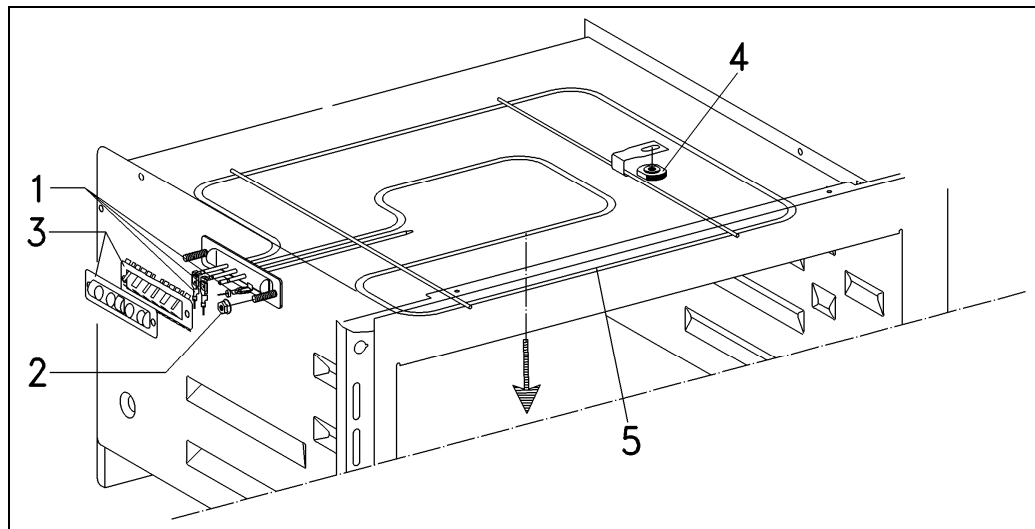

Figure 032-7: Broil Heater Element Removal

Danger!

After installation is completed, as a matter of standard practice, check the oven for a tight seal with a microwave leak detector, paying particular attention to the door and the housing edges.

Technical Information

040 Control Panel, Electrical System

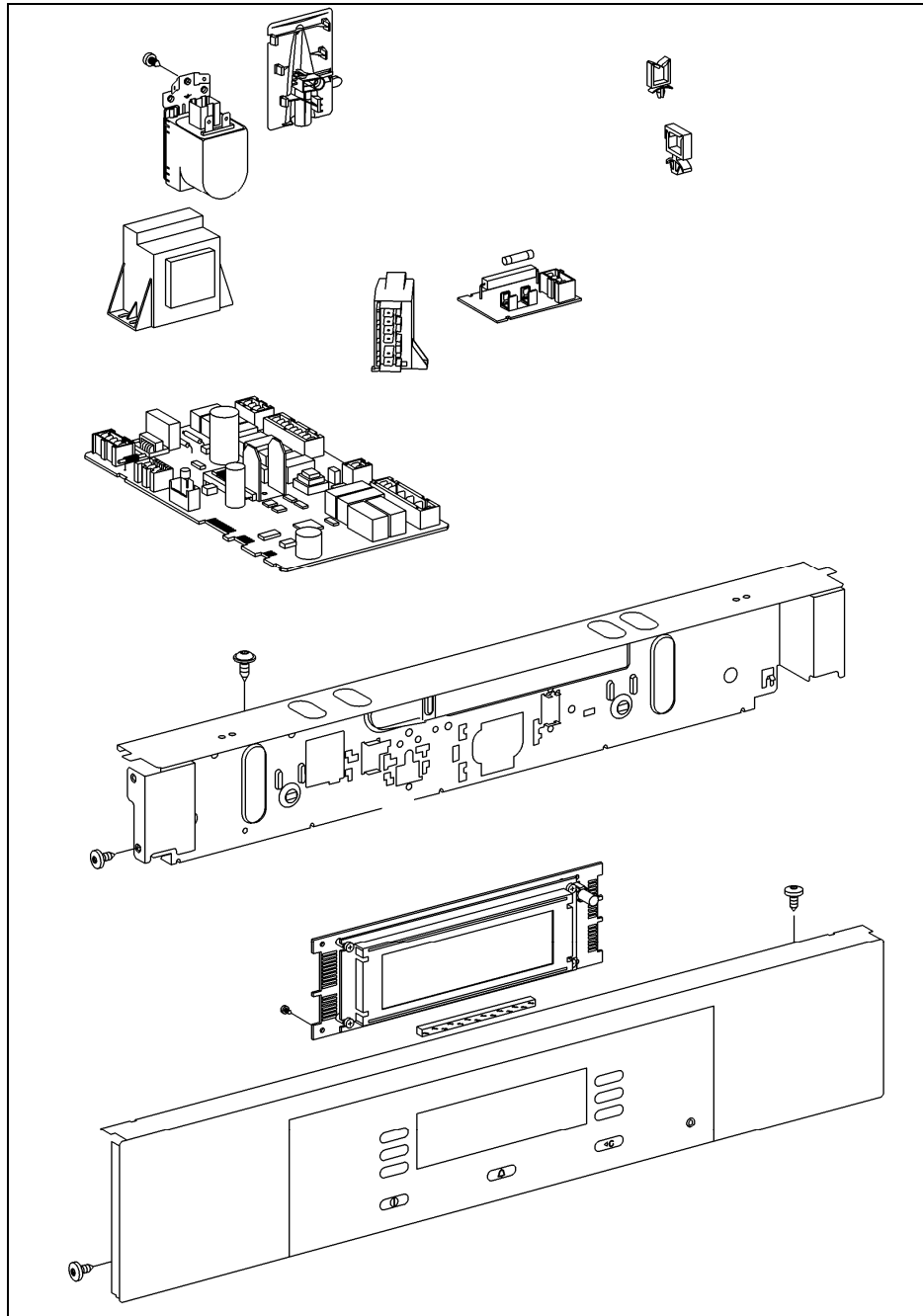

2 Function

2.1 Navitronic Touch Display

2.1.1 Design

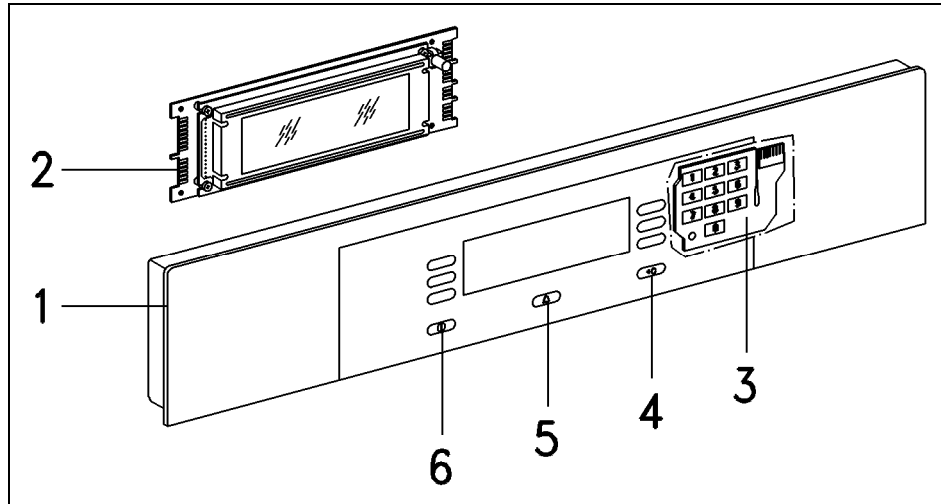

Figure 040-1: Navitronic Display (H 4080 BM Shown)

- 1 Control panel
- 2 Control electronic (EPX)
- 3 Program electronic (EW)
- 4 **Clear** touchpad (delete last entry/go back)
- 5 **Timer** touchpad (minute minder)
- 6 **Minute +** touchpad (quick-start function)
- 7 **On/Off** touchpad (on/off switch)

The Navitronic touch display consists of two electronics located behind each other in the control panel (Figure 040-1, Item 1). The front program electronic (Figure 040-1, Item 3) has 10 touchpads and a numeric keypad from 0 to 9 for numerical entries. The touchpads respond to finger contact and each contact is confirmed by a tone. This confirmation tone can be turned on or off in the customer programming mode.

Note:

The Navitronic display shown in Figure 040-1 is for an H 4080 BM. On an H 4082 BM, the **Clear** and **Timer** touchpads (Items 4 and 5) are switched.

The four touchpads located in a horizontal line below the display are allocated to fixed functions. The three touchpads to the right and left of the display are variable. They control the menu items next to them, marked by ● or ✓.

An optical fiber module is located behind the numeric keypad, which lights up when a numerical entry is possible or required.

The control electronic (Figure 040-1, Item 2) is located behind the program electronic. It contains the text display for the navigation and the optical interface.

Technical Information**2.1.2 Operating Principle**

The display shows the available menu items marked with ● or ✓. By touching the pad next to it, the requested menu item is selected. If there is a choice of more than five menu items, scroll forward or back by selecting **more** or **back**.

If a numerical entry is possible or required (such as cooking time or temperature), the numeric keypad next to the display lights up. Then, and only then, can a selection be made by touching the numerical fields.

Touching the pad next to **OK** confirms a selection or input. The display will then revert to the previous menu.

2.1.3 Optical Interface

Figure 040-2: Optical Interface

The appliance has an optical interface to support diagnostics and programming (refer to Figure 040-2, Item 1). It can be located with the function "Find optical interface" of the Miele diagnostic support (MDU).

2.2 Connectors on Power Electronic EPL (1N1) (H 4080 BM Only)

Note:
 Plug and pin designations are the same as in the wiring diagram.

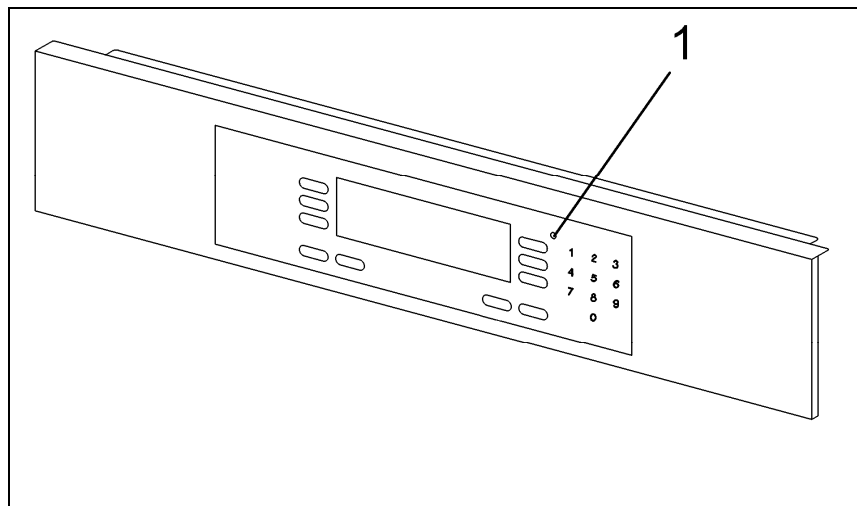
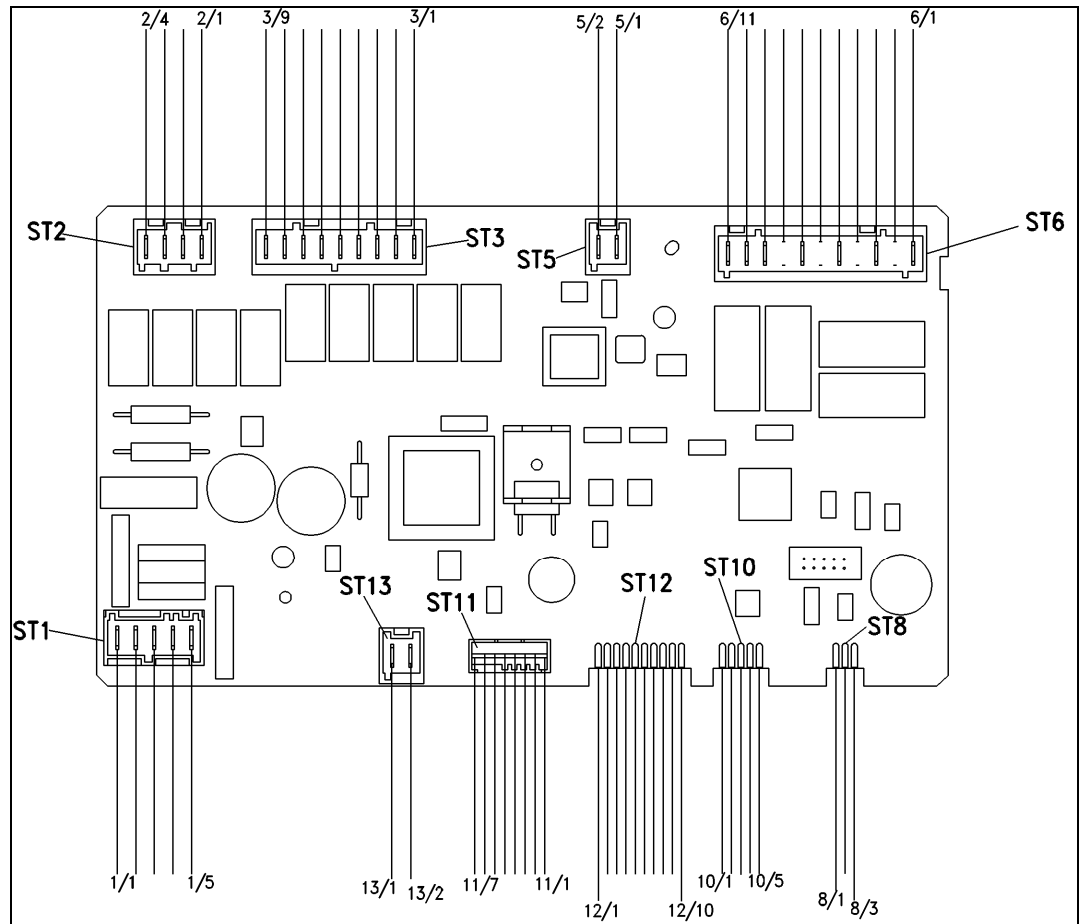

Figure 040-3: Power Electronic (H 4080 BM)

Technical Information

ST1	Plug 1
1/1	Interference suppression filter (Z1)
1/2	ACN
1/3	vacant
1/4	vacant
1/5	vacant
ST2	Plug 2
2/1 - 2/4	vacant
ST3	Plug 3
3/1	Cooling fan (M2/1) connection 2 - RPM N1 (low speed)
3/2	vacant
3/3	Cooling fan (M2/1) connection 1- RPM N2 (high speed)
3/4	Release element (Y56)
3/5	vacant
3/6	Convection fan (M2/2)
3/7	Oven light transformer (2T1)
3/8	vacant
3/9	Bridge to 6/1
ST5	Plug 5
5/1	Roast probe socket (X5/8)
5/2	Roast probe socket (X5/8)
ST6	Plug 6
6/1	Electronic EV (3N1), bridge to 3/9
6/2	vacant
6/3	Convection heater element (R14)
6/4	vacant
6/5	Broil heater element (R15)
6/6	vacant
6/7	Electronic (3N1)
6/8	vacant
6/9	vacant
6/10	Door contact switch (4F6/6)
6/11	Wave distributor motor (M21), electronic EV (3N1)
ST8	Plug 8
8/1	PT1000 temperature sensor (1R30)
8/2	vacant
8/3	PT1000 temperature sensor (1R30)

ST10	Plug 10
10/1	Safety relay (K1)
10/2	Safety relay (K1)
10/3	Thermostat, oven cavity (275°F) (1F1)
10/4	Thermostat, oven cavity (275°F) (1F1)
10/5	vacant
ST11	Plug 11
11/1	Cooling fan (M2/1)
11/2	Cooling fan (M2/1)
11/3	Cooling fan (M2/1)
11/4	vacant
11/5	vacant
11/6	vacant
11/7	vacant
ST12	Plug 12
12/1 – 12/10	Control electronic (2N1)
ST13	Plug 13
13/1	Door contact safety switch (F5 6/6)
13/2	Door contact safety switch (F5 6/6)

Table 040-1: Power Electronic Connections (H 4080 BM)

2.3 Connectors on Power Electronic ELP (1N1) (H 4082/4/6/8 BM)

Note:

Plug and pin designations are the same as in the wiring diagram.

Technical Information

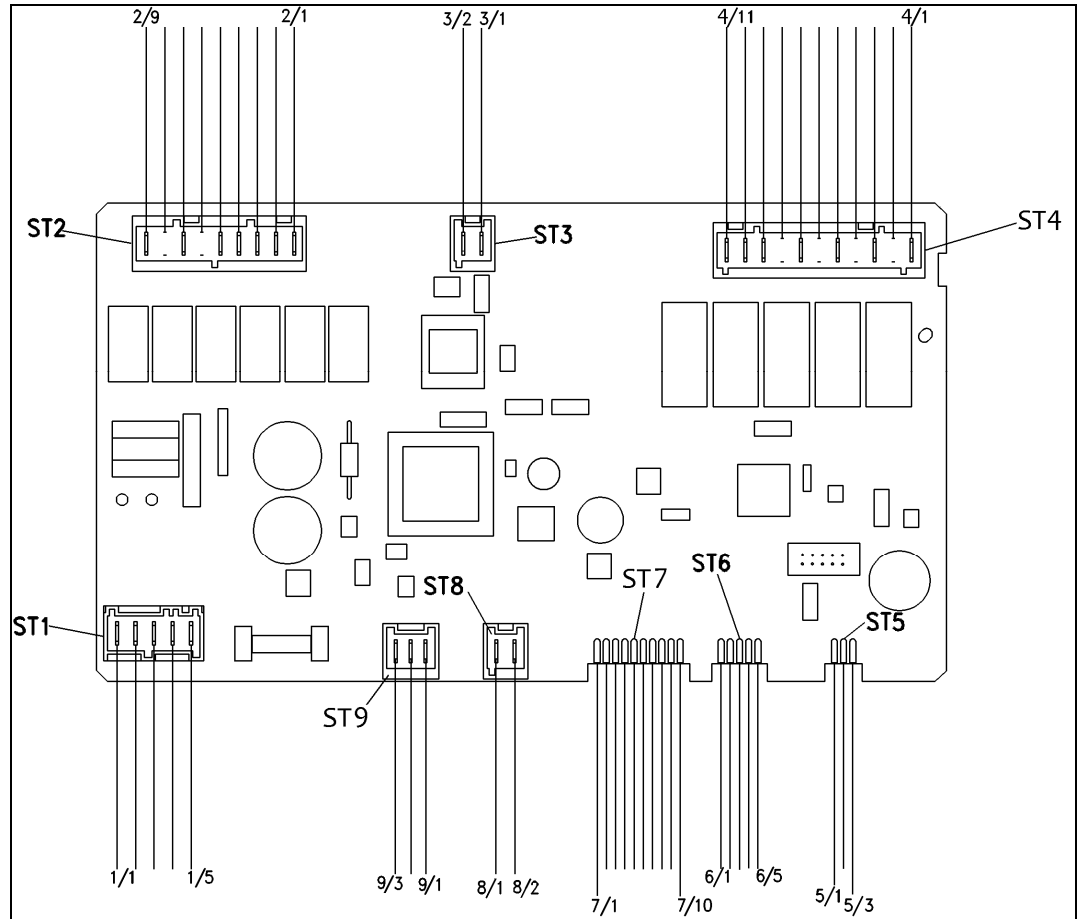

Figure 040-4: Power Electronic (H 4082/4/6/8 BM)

ST1	Plug 1
1/1	Neutral on terminal block
1/2	Interference suppression capacitor (Z2)
1/3	Chassis ground
1/4	L1 on terminal block, bridge to 4/11
1/5	Door interlock primary switch – left side (F 6/6-4)
ST2	Plug 2
2/1	Cooling fan (M2/1) connection 2 - RPM N1 (low speed)
2/2	Cooling fan (M2/1) connection - neutral
2/3	Cooling fan (M2/1) connection 1- RPM N2 (high speed)
2/4	Release element (Y56)
2/5	Convection fan (M2/2)
2/6	vacant
2/7	Oven light transformer (2T1)
2/8	vacant
2/9	Bridge to 4/10

Technical Information

ST3	Plug 3
3/1	Roast probe socket (X5/8)
3/2	Roast probe socket (X5/8)
ST4	Plug 4
4/1	High-voltage transformer (1T1), wave distributor motor (M21)
4/2	vacant
4/3	Door interlock monitor switch – right side (F6/6-7)
4/4	vacant
4/5	Convection heater element (R14)
4/6	vacant
4/7	Broil heater element (R15)
4/8	vacant
4/9	Floor heater element (R12)
4/10	Bridge to 2/9 and 4/11
4/11	Bridge to 4/10 and 1/4
ST5	Plug 5
5/1	PT1000 temperature sensor (1R30)
5/2	vacant
5/3	PT1000 temperature sensor (1R30)
ST6	Plug 6
6/1	Thermostat, oven cavity (275°F) (1F1)
6/2	vacant
6/3	vacant
6/4	Thermostat, oven cavity (275°F) (1F1)
ST7	Plug 7
7/1 - 7/10	Control electronic (2N1)
ST8	Plug 8
8/1	Door switch (S24)
8/2	Door switch (S24)
ST9	Plug 9
9/1	Cooling fan (M2/1)
9/2	Cooling fan (M2/1)
9/3	Cooling fan (M2/1)

Table 040-2: Power Electronic Connections (H 4082/4/6/8 BM)

3 Fault Repair

3.1 Fault Code Summary

Cause:

Refer to fault code tables.

Technical Information

Fault Code	Fault Description	Cause/Remedy
F05	Short circuit, oven PT1000 temperature sensor	Refer to Section 040-3.2.
F06	Open circuit, oven PT1000 temperature sensor	Refer to Section 040-3.3.
F44	Control electronic/power electronic interface defective	Refer to Section 040-3.4.
F54	Short circuit, roast probe	Refer to Section 040-3.5.
F55	Safety cutoff	Refer to Section 040-3.6.
F60	Temperature of power electronic is too high	Refer to Section 040-3.7.

Table 040-3: Fault Codes

Remedy:

Refer to the respective fault code.

3.2 F05 – Short Circuit, Oven Temperature Sensor

Cause:

Oven temperature sensor (1R30) short-circuited.

Remedy:

1. Check all connectors.
2. Replace connectors as necessary.
3. Check the oven temperature sensor in service mode; see Section 040-4.3.
4. Replace the temperature sensor as necessary.

3.3 F06 – Open Circuit, Oven Temperature Sensor

Cause:

Oven temperature sensor (1R30) open-circuited.

Remedy:

1. Check all connectors.
2. Replace connectors as necessary.
3. Check the oven temperature sensor in service mode; see Section 040-4.3.
4. Replace the temperature sensor as necessary.

3.4 F44 – Control Electronic/Power Electronic Interface Defective

Symptom:

Communication between control electronic (2N1) and power electronic (1N1) interrupted.

Cause:

Connector between control electronic (2N1) and power electronic (1N1) defective.

Remedy:

Check connector.
Replace connector as necessary.

Cause:

Control electronic (2N1) defective.

Remedy:

Replace control electronic.

Cause:
Power electronic (1N1) defective.

Remedy:
Replace power electronic.

3.5 **F54 – Short Circuit, Roast Probe**

Cause:
Temperature sensor 2R30 short-circuited.

Remedy:

1. Check connectors.
2. Replace connectors as necessary.
3. Check the roast probe temperature sensor in the service mode; see Section 040-4.3.
4. Replace the roast probe temperature sensor as necessary.

3.6 **F55 – Safety Cutoff**

Symptom:
After 6 hours or 12 hours, depending on operating mode, the appliance switches off automatically.

Cause:
The appliance was not switched off.

Remedy:
No action necessary; the appliance is in working order.

3.7 **F60 – Temperature of Power Electronic Too High**

Symptom:
The temperature of the power electronic (1N1) is too high.

Cause:
Insufficient ducting.

Remedy:

1. Check the ducting; refer to Section 012-2.1.
2. Check the cooling fan connectors; replace as necessary.
3. Check the cooling fan in service mode; see Section 040-4.3.
4. Replace the cooling fan as necessary.

3.8 **Incorrect Language Was Set**

Cause:
Different languages can be programmed.

Remedy:
Use the  icon as a guide to program the desired language.

3.9 **Time Display in 24-Hour Format/12-Hour Format**

Cause:
The time format can be programmed.

Remedy:
See Section 040-4.1.

Technical Information**3.10 Oven Light Goes Out/Does Not Go Out****Cause:**

The oven light can be programmed.

Remedy:

See Section 040-4.1.

3.11 Modes in the Main Menu Were Changed**Cause:**

The modes in the main menu can be programmed.

Remedy:

The first four modes in the main menu can be replaced with other modes or programs that are used more often.

3.12 Cooking Process Does Not Start**Cause:**

Start was set to 'manual'.

Start can be programmed as automatic or manual. If start was set to 'manual', then the start of a cooking process must be confirmed manually.

Remedy:

Set start to 'automatic'.

3.13 Recommended Temperatures Are Changed**Cause:**

The recommended temperatures can be programmed.

Remedy:

See Section 040-4.1.

3.14 Display Dims**Cause:**

The display can be programmed.

Remedy:

See Section 040-4.1.

3.15 Display Is Too Bright/Too Dark**Cause:**

The display brightness can be programmed.

Remedy:

See Section 040-4.1.

3.16 Displays Look Different**Symptom:**

The displays of different appliances with Navitronic controls (H 4000, H 4000 BM, DG 4050) look different.

Cause:

Different placement (appliances side by side, one on top of another); different light reflection.

Remedy:

Adjust using the “brightness” and “contrast” programming functions (refer to Section 040-4.1).

3.17 Buzzer Tone Too Loud/Too Soft**Cause:**

The buzzer can be programmed.

Remedy:

See Section 040-4.1.

3.18 System Lock Cannot Be Activated**Symptom:**

The  icon is not in the display.

Cause:

To accept or not accept the system lock can be programmed.

Remedy:

See Section 040-4.1.

3.19 Weight in Pounds**Cause:**

Weight units can be programmed.

Remedy:

See Section 040-4.1.

3.20 Temperature in °C/°F**Cause:**

The temperature format can be programmed.

Remedy:

See Section 040-4.1.

3.21 Appliance Does Not Heat**Cause:**

Demo mode is activated.

Remedy:

Deactivate the demo mode. (Not applicable in all models.)

3.22 Fuse Trips**Cause:**

The door safety switch is defective.

Remedy:

1. Check all door contact safety switches (refer to Figure 011-8).
2. Replace the door lock with the defective safety switch (refer to Section 011-4.8).
3. Replace fuse.

Technical Information**Note:**

Use only an original Miele microfuse, which has special release characteristics. Using other brands can cause malfunctions.

Note:

12-amp fuses were used in the current production run. If the fuse in the appliance is a 10-amp fuse, it can be replaced with a 12-amp one if/when it trips.

Cause:

Short circuit in the high-voltage assembly.

Remedy:

1. Fix the short circuit, testing all electrical components and connectors, and replacing them as necessary:
 - a. Transformer (Section 012-4.12)
 - b. High-voltage capacitor (Sections 012-4.14 and 012-4.15)
 - c. Diode V1 (Section 012-4.16)
 - d. Protective diode V6 (Section 012-4.17)
 - e. Magnetron (Section 012-4.8)
2. Replace the fuse.

Note:

Use only an original Miele microfuse, which has special release characteristics. Using other brands can cause malfunctions.

Note:

12-amp fuses were used in the current production run. If the fuse in the appliance is a 10-amp fuse, it can be replaced with a 12-amp one if/when it trips.

3.23 Roast Probe Shows Wrong Values**Cause:**

Grease deposits on the roast probe plug.

Remedy:

Clean the roast probe, including the plug.

3.24 Safety Relay (K1) Trips**Cause:**

Fault in power electronic (1N1).

Remedy:

Replace the power electronic.

Cause:

Fault in control electronic (2N1).

Remedy:

Replace the control electronic.

Cause:

Oven cavity temperature too high.

Thermostat 1F1/1 temperature exceeds 275°F (135°C). The thermostat

Technical Information

activates the safety relay, which switches off both heaters.

Remedy:

1. Check the cooling fan in service mode; see Section 040-4.3.
2. Replace the cooling fan as necessary; refer to Section 012-4.5 or 012-4.6.
3. Replace the oven cavity thermostat (1F1/1).

4 Service

4.1 Programming Mode Overview (H 4080 BM)

Initial requirements:

Switch the appliance off.

Accessing:

Note:
Complete the access procedure within 10 seconds.

1. Touch and hold the **Clear** pad.
2. Touch the **On/Off** pad.
3. Release the **Clear** pad.
4. Touch the **Clear** pad 5 times and on the 5th time **hold it** until the programming mode appears.

Acknowledgement indicator:

The display shows the following items of **PROGRAMMING**:

- LANGUAGE ...
- CLOCK ...
- TEMPERATURE ...
- OVEN LIGHT ... ✓
- TEMPERATURE °F ✓
- more ✓

Options:

Touch the pad next to the desired function (refer to Table 040-4).

Function	Setting	Factory Setting
LANGUAGE	English	English
	Deutsch	
	Espanol	
	Francais	
	Italiano	
	Polski	
	Portuguese	

Technical Information

Function	Setting		Factory Setting
CLOCK	Size	Normal	Normal
		Large	
	12-hour format		12-hour format
	24-hour format		
	Clock Display	On	On
Off			
ENTER TIME	hh:mm	--	
TEMPERATURES	CONVECTION BAKE	125 to 435°F	325°F
	CONVECTION BROIL	200 to 400°F	400°F
	AUTO ROAST	200 to 425°F	325°F
	DEFROST	75 to 125°F	75°F
OVEN LIGHT	Off after 1 minute		Off after 1 minute
	On during use		
TEMPERATURE °F/°C	°C		°F
	°F		
TONE OPTIONS	Timer 1 Tone	1 - 5	1
	Timer 2 Tone	1 - 5	1
	Keypad Tone	On	On
		Off	
	Volume	1 - 5	2
	Tone	Short	Short
Long			
DISPLAY	Brightness	1 - 5	3
	Contrast	1 - 5	3
SYSTEM LOCK	Do not accept		Do not accept
	Accept		
KEEP WARM	On		Off
	Off		
POWER LEVEL	Microwave	(7 levels)	1000W (240V)
			850W (208V)
	Combinations	(4 levels)	450W

Function	Setting		Factory Setting
RESET	Temperatures	YES	--
		NO	
	Settings	YES	--
		NO	
	Favorites	YES	--
		NO	
RESTART	--		--
208V/240V	208V		208V
	240V		

Table 040-4: H 4080 BM Programming Mode

To go back:

Touch the **Clear** pad. The display reverts to the previous menu.

Save and go back:

Confirm by touching the pad next to **OK** ✓. The selected setting is saved. The display reverts to the previous menu.

Save and quit:

Touch the pad next to **OK** ✓.
Touch the **On/Off** pad.

Quit without saving:

Touch the **On/Off** pad.

4.2 Programming Mode Overview (H 4082/4/6/8 BM)

Initial requirements:

Switch the appliance off.

Accessing:**Note:**

Complete the access procedure within 10 seconds.

1. Touch and hold the **Timer** pad.
2. Touch the **On/Off** pad.
3. Release the **Timer** pad.
4. Touch the **Timer** pad 5 times and on the 5th time **hold it** until the programming mode appears.

Acknowledgement indicator:

The display shows the following items of **PROGRAMMING**:

- LANGUAGE  ...
- CLOCK ...
- TEMPERATURE ...
- OVEN LIGHT ... ✓
- TEMPERATURE °F ✓

Technical Information

more ✓

Options:

Touch the pad next to the desired function (refer to Table 040-5).

Function	Setting		Factory Setting
RESET	Temperatures	--	--
	Settings	--	--
	Favorites	--	--
LANGUAGE  1	English		English
	Deutsch		
	Espanol		
	Francais		
	Italiano		
	Polski		
	Portuguese		
CLOCK	Size	Normal	Normal
		Large	
	12-hour format		12-hour format
	24-hour format		
	Clock Display	On	On
		Off	
ENTER TIME	hh:mm	--	
TEMPERATURES	BAKE	200 to 475°F	375°F
	SURROUND	125 to 475°F	375°F
	INTENSIVE	200 to 475°F	325°F
	CONVECTION BAKE	125 to 435°F	325°F
	CONVECTION BROIL	200 to 400°F	400°F
	AUTO ROAST	200 to 425°F	325°F
	CONVECTION ROAST	200 to 475°F	325°F
	SURROUND ROAST	125 to 475°F	325°F
OVEN LIGHT	Off after 1 minute		Off after 1 minute
	On during use		
TEMPERATURE °F/°C	°F		°F
	°C		

Function	Setting		Factory Setting
TONE OPTIONS	Timer 1 Tone	1 - 5	1
	Timer 2 Tone	1 - 5	1
	Keypad Tone	On	On
		Off	
	Volume	1 - 5	2
Tone	Short	Short	
	Long		
DISPLAY	Brightness	1 - 5	3
	Contrast	1 - 5	3
SYSTEM LOCK	Do not accept		Do not accept
	Accept		
KEEP WARM	On		Off
	Off		
POWER LEVEL	Microwave	(7 levels)	1000W (240V)
			850W (208V)
	Combinations	(4 levels)	450W
208V/240V	208V		208V
	240V		

Table 040-5: H 4082/4/6/8 BM Programming Mode

¹ Available languages will depend on the installed electronic version.

To go back:

Touch the **Clear** pad. The display reverts to the previous menu.

Save and go back:

Confirm by touching the pad next to **OK** ✓. The selected setting is saved. The display reverts to the previous menu.

Save and quit:

Touch the pad next to **OK** ✓.
Touch the **On/Off** pad.

Quit without saving:

Touch the **On/Off** pad.

4.3 Service Mode Overview (H 4080 BM)

Initial requirements:

Switch the appliance off.

Accessing:**Note:**

Complete the access procedure within 10 seconds.

Technical Information

1. Touch and hold the **Clear** pad.
2. Touch the **On/Off** pad.
3. Release the **Clear** pad.
4. Touch the **Clear** pad 3 times and on the 3rd time **hold it** until the service mode appears.

Acknowledgement indicator:

The display shows the following items of **SERVICE**:

- INDEX...
- FAULT INDEX...
- FUNCTION TEST...

SENSOR TEST... ✓

RUNNING TIME... ✓

Options:

Touch the pad next to the desired function (refer to Table 040-6).

Service Function	Option	
INDEX...	CONTROL EPX	e.g., ID000853
	POWER EPL	e.g., ID000793
FAULT INDEX...	No faults	--
	Faults stored	Fault 01, Fault 02... Clear faults
FUNCTION TEST...	ALL OFF	All previously activated components will be shut off.
	BROILING	On
		Off
	CONVECTION	On
		Off
	CONVECTION FAN	On
		Off
	COOLING FAN	On low
		On high
		Off
	MAGNETRON	On
		Off
	INTERIOR LIGHTING	On
		Off
DOOR CONTROL	On	
	Off	
BUZZER	On	
	Off	
DISPLAY	3 s on / 3 s dark	

Service Function		Option
SENSOR TEST...	DOOR SWITCH	Closed
		Open
	ROAST PROBE	Displays temperature.
	TEMP. INTERIOR	Displays temperature.
	BUTTON TEST	Button test.
RUNNING TIME...		Displays hours as 0000h.

Table 040-6: Service Mode (H 4080 BM)

Go back:

Touch the **Clear** pad. The display reverts to the previous menu.

Quit:

Touch the **On/Off** pad.

4.4 Service Mode Overview (H 4082/4/6/8 BM)

Initial requirements:

Switch the appliance off.

Accessing:**Note:**

Complete the access procedure within 10 seconds.

1. Touch and hold the **Timer** pad.
2. Touch the **On/Off** pad.
3. Release the **Timer** pad.
4. Touch the **Timer** pad 3 times and on the 3rd time **hold it** until the service mode appears.

Acknowledgement indicator:

The display shows the following items of **SERVICE**:

- INDEX...
- FAULT INDEX...
- FUNCTION TEST...

SENSOR TEST... ✓

RUNNING TIME... ✓

Options:

Touch the pad next to the desired function (refer to Table 040-7).

Service Function		Option
INDEX...	CONTROL EPX792	e.g., ID000936
	POWER EPL792	e.g., ID000002
FAULT INDEX...	No faults	--
	Fault registered	Fault 01, Fault 02...
		Clear faults

Technical Information

Service Function	Option	
FUNCTION TEST...	ALL OFF	All previously activated components will be shut off.
	BROILING	On
		Off
	BOTTOM HEAT	On
		Off
	CONVECTION	On
		Off
	CONVECTION FAN	On
		Off
	COOLING FAN	On
		Off
	MAGNETRON	On
Off		
INTERIOR LIGHTING	On	
	Off	
DOOR CONTROL	On	
	Off	
BUZZER	On non-stop	
	Off	
DISPLAY	Display alternates 3 s lit up / 3 s dark	
SENSOR TEST...	DOOR SWITCH	Closed
		Open
	ROAST PROBE	not connected e.g., 68°F
	TEMP. INTERIOR	e.g., 30°C
KEYPAD	e.g., button 4 pressed	
RUNNING TIME...	e.g., 0008 h	

Table 040-7: Service Mode (H 4082/4/6/8 BM)

Go back:

Touch the **Clear** pad. The display reverts to the previous menu.

Quit:

Touch the **On/Off** pad.

4.5 Reading and Deleting the Fault Memory

Initial requirements:

Switch the appliance off.

Accessing:

Access the service mode as outlined in Section 040-4.3 or 040-4.4.

Acknowledgement indicator:

The display shows the list of service functions.

Options:

Touch the pad to the left of **FAULT INDEX....**

Faults are indicated numerically with the most recent fault displayed first:

Fault 04, Fault 03, Fault 02, etc.

Touch the pad next to the fault displayed.

The fault is indicated in standard text, e.g., **Communication ST - LT**.

Delete faults:

Touch the pad next to **Clear Faults**.

Go back:

Touch the **Clear** (or **Timer**) pad. The display reverts to the previous menu.

Quit:

Touch the **On/Off** pad.

4.6 Fascia Panel Removal

1. Remove the appliance from its cabinet; see Section 011-4.3.
2. Remove the screws securing the appliance lid. Remove the lid.

Danger!

Before performing any service or repair work, discharge the high-voltage capacitor. See Section A-2.

3. Open the door.
4. Remove the screws securing the sides of the fascia panel (Figure 040-4, Item 1).
5. Remove the screws securing the top of the fascia panel (Figure 040-4, Item 2).

Note:

The screws securing the sides of the fascia panel are fine thread screws, and the screws securing the top of the fascia panel are coarse thread screws. Take care not to mix them up!

6. Disconnect the connections from the programming and control electronics.
7. Lift off the fascia panel with electronics and remove.

Technical Information

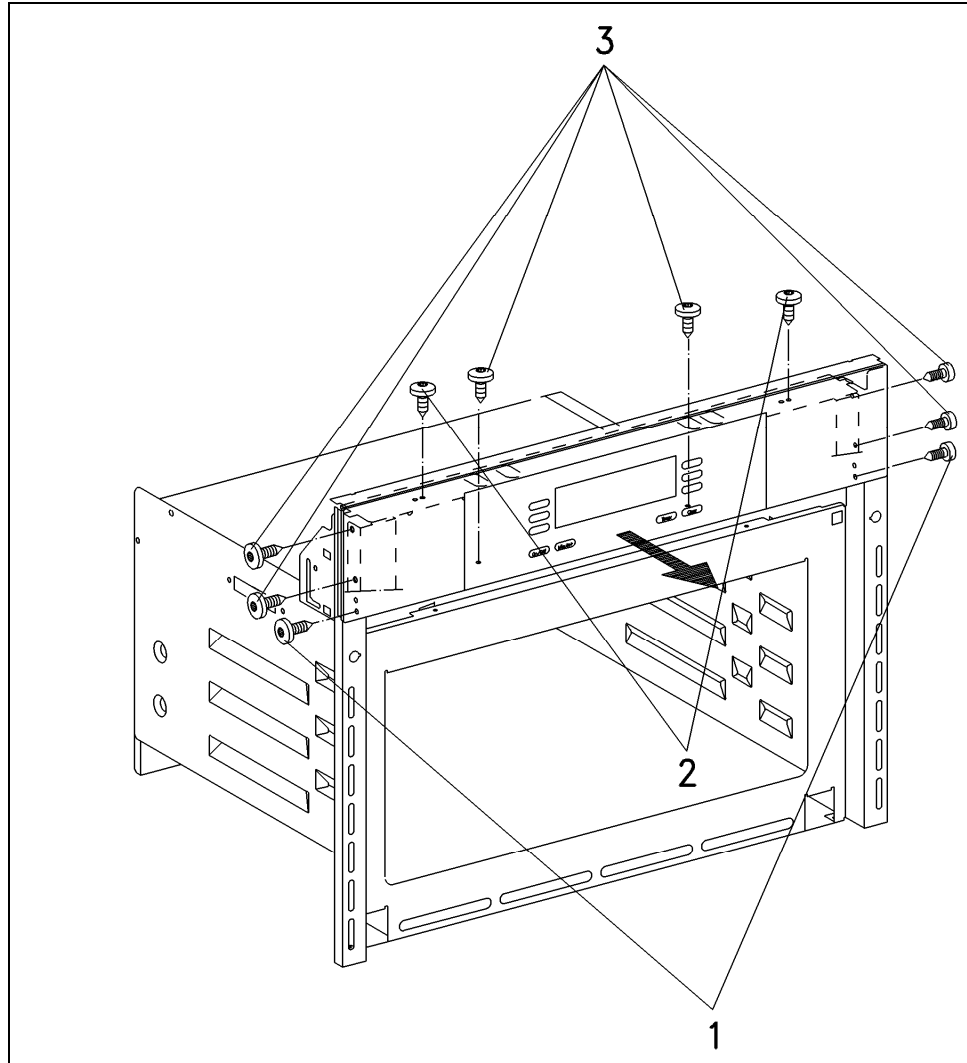
**Figure 040-4:** Fascia Panel Removal**4.7****Removing the Fascia Panel with Support Plate**

1. Remove the appliance from its cabinet; see Section 011-4.3.
2. Remove the securing the appliance lid. Remove the lid.

Danger!

Before performing any service or repair work, discharge the high-voltage capacitor. See Section A-2.

3. Remove the door spring. See Section 011-4.6.
4. Open the door.
5. Remove the T20 screws securing the sides of the fascia panel (Figure 040-4, Item 1).
6. Loosen the screws securing the sides of the support plate (Figure 040-4, Item 3). Pull the fascia panel/support plate forward and disconnect the ribbon cable.
7. Remove the fascia panel with support plate.

4.8 Support Plate Removal

1. Remove the appliance from its cabinet; see Section 011-4.3.
2. Remove the screws securing the appliance lid. Remove the lid.

Danger!

Before performing any service or repair work, discharge the high-voltage capacitor. See Section A-2.

3. Remove the fascia panel. See Section 040-4.5.
4. Remove the door spring. See Section 011-4.6.
5. Remove the screws securing the support panel (Figure 040-4, Item 3).
6. Remove the panel.

4.9 Power Electronic Removal

1. Remove the appliance from its cabinet; see Section 011-4.3.
2. Remove the screws securing the appliance lid. Remove the lid.

Danger!

Before performing any service or repair work, discharge the high-voltage capacitor. See Section A-2.

3. Disconnect all connections from the power electronic.
4. Release the power electronic board from its retainers at the corners and sides.

080 Technical Service Bulletins**1 H4XXX Cooling Fan Behavior**

All Miele ovens are equipped with cooling fans. Their purpose and behavior are not always completely understood. To avoid confusion and unnecessary service visits, the following explanation should be used whenever dealing with a customer or dealer inquiry.

The cooling fans in Miele ovens are primarily designed to remove heat from the oven cabinet and keep the electronic components from overheating. A secondary purpose is to prevent the buildup of moisture and condensation on these electronic parts. This contributes to the reliability and longevity of the oven. The cooling fan will always continue to run after the oven is switched off. The amount of time that the fan runs is determined by sensors in the oven and computer logic built into the oven's software. There is no formula or fixed amount of time for this fan to operate. It's possible that the fan could run for several hours. This is by design; there is nothing wrong with the oven.

Service note:

All oven cooling fans (including speed ovens) are equipped with a speed sensor. This sensor is a Hall-effect semiconductor device and its proper operation cannot always be determined using a multimeter. If an oven refuses to heat, always remember to check the operation of the cooling fan at all available speeds. If the electronic does not detect a signal from the fan, the main heater relay (1K1, 2K1) will not energize. A good example of this behavior can be illustrated with a speed oven. Microwave and Convection modes use speeds 1 and 2 on the fan. Combi-Mode uses speed setting 3. If for some reason the fan will not run when speed 3 is selected, only that mode will not heat. Other modes will continue to function.

2 H 4080 BM Control Panel Fogging

In some instances, the control panel of a speed oven may begin to fog up on the inside. This is usually the result of a heavy cooking cycle with high moisture content in the food. If the customer finds this to be a recurring problem, there is a fix for this:

1. Order part number 07093411 (seal).
2. Install the seal as illustrated below.

Note: The seal is longer than the cover plate and will need to be trimmed. Be sure to install the seal with the 'bulge' facing down.



3 Speed Oven Broil Element Replacement

This applies to all H 408x BM speed ovens. When replacing the broil element, there is a new conversion kit. This kit also comes with the mounting stud, hardware, and knurled nut. **All parts in the kit must be installed when replacing the element.** The new part number is 09243190. Please refer to the photo.

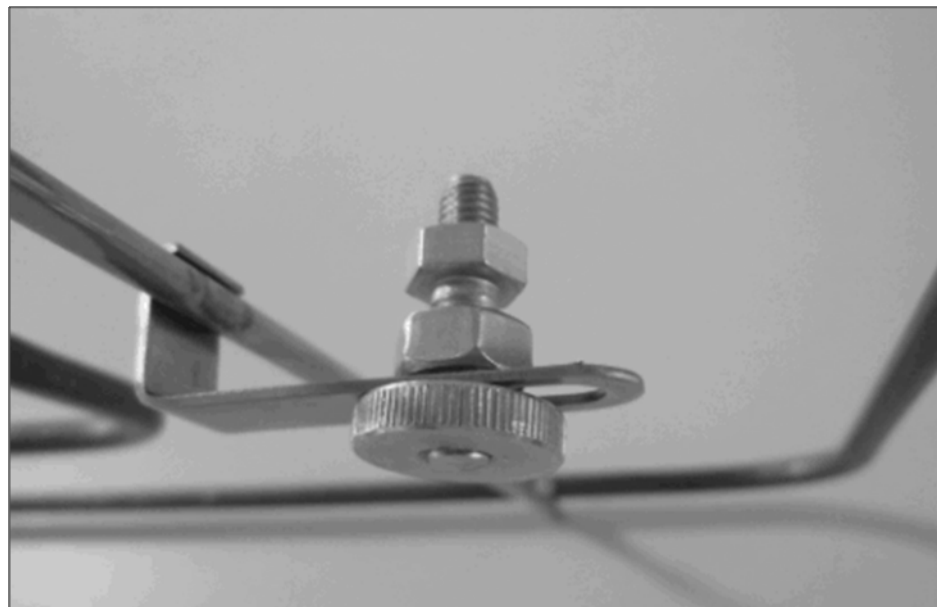

4 Speed Ovens: Optional Waveguide Cover

In our speed ovens, there is a cover that protects the stirrer blade and other microwave components from food spatters, grease and moisture. This cover is made from a semi-rigid material containing mica and is designed to be radio-transparent to the microwave energy.

Over time, this cover can overheat, deteriorate or be damaged by excessive or aggressive cleaning or by cooking habits that cause excessive spattering. A service call is necessary to replace this cover. In cases where this may

Technical Information

occur more frequently, we have an **optional** replacement part made from porcelain which will withstand the most rigorous cleaning and cooking practices. When installing the porcelain cover, be sure it is oriented with the smooth side facing the cavity, and note the positioning of the clips. If the clips are installed improperly, the cover will not be secure and it will rattle. (See the photos.)

The standard replacement cover is currently part number 5737731, and is shown as Item #10 in the diagram. The optional cover is currently part number 7862320, and is illustrated as Item #12 (+11 and +13) in the diagram. This drawing is from an H 4080 BM (for clarity), but the same applies to all speed ovens. Be sure to consult the ETD for the latest part numbers, as these could change in the future.

