

Seating - Rear Seat Backrest Cover Vehicles With: 40/20/40 Split Seat

Removal and Installation

Removal

1. Remove the inner backrest hinge cover.

- Release the backrest cover side clip.
- Remove the screw.
- Release the 2 clips.

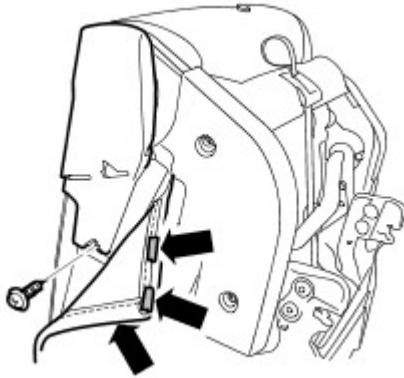

E55971

2. Remove the outer backrest hinge cover.

- Remove the screw.

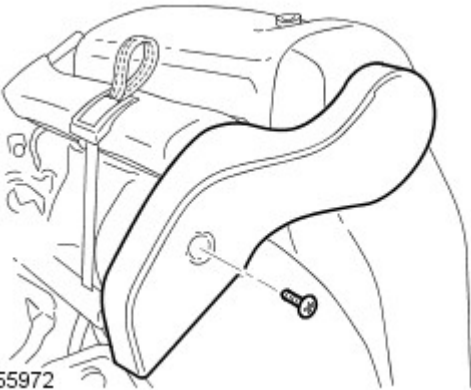

E55972

3. Remove the rear seat cushion side finisher.

- Remove the 2 screws.

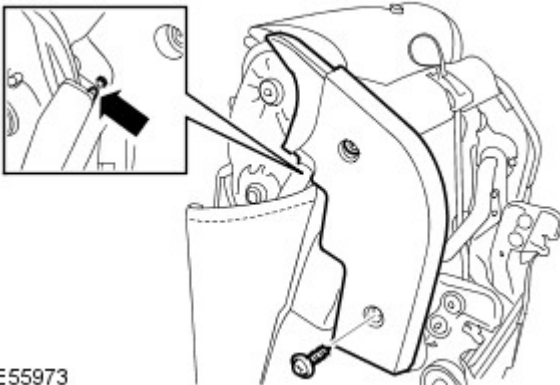

E55973

4. Remove the luggage strap tether.

- Remove the Allen bolt.

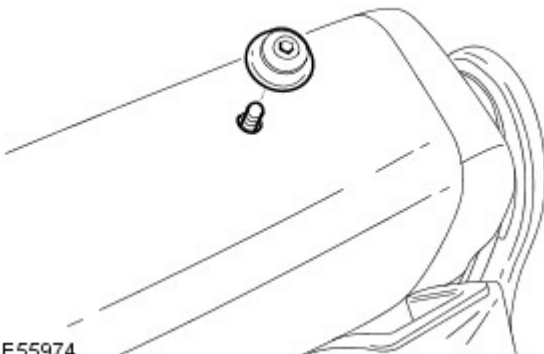

E55974

5. Remove the rear seat head restraint.

- Depress the 2 retaining clips.

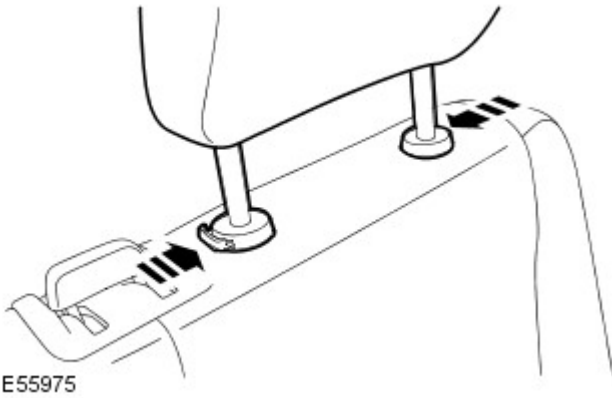

E55975

6. Remove the rear seat head restraint retaining clips.

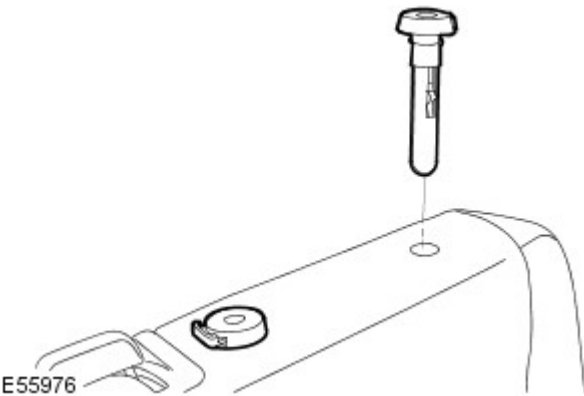

E55976

7. Remove the rear seat release handle.

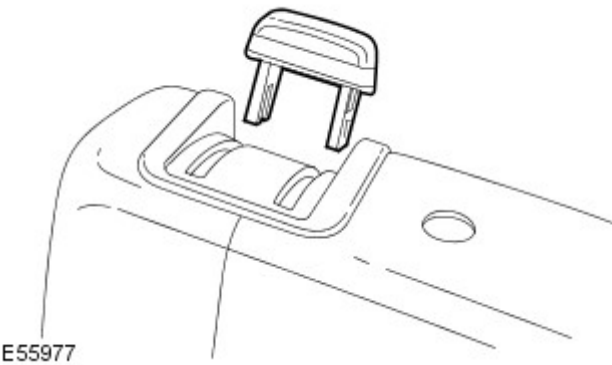

E55977

8. Remove the rear seat release handle finisher.

- Remove the screw.



E55978

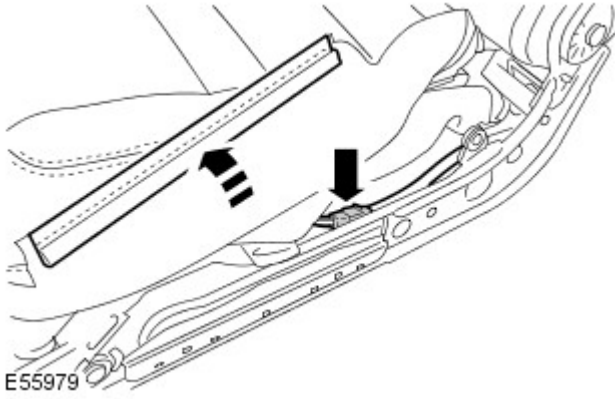

9. Disconnect the backrest heater mat electrical connector.

- Release the rear seat cushion side clip.

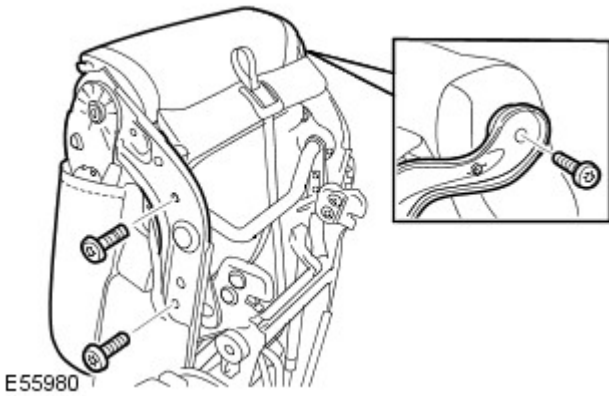

10. Remove the rear seat backrest assembly.

- Remove the 3 Torx bolts.

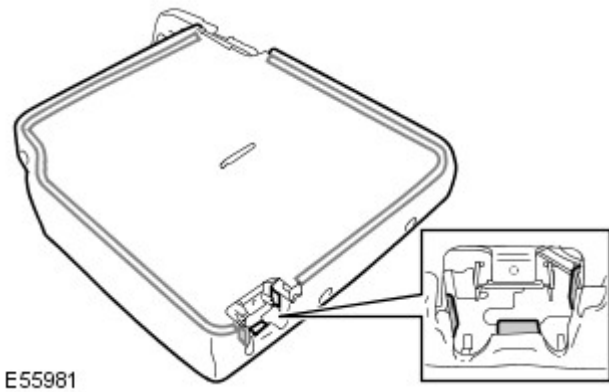

11. Release the rear seat backrest cover.

- Release the 5 clips.

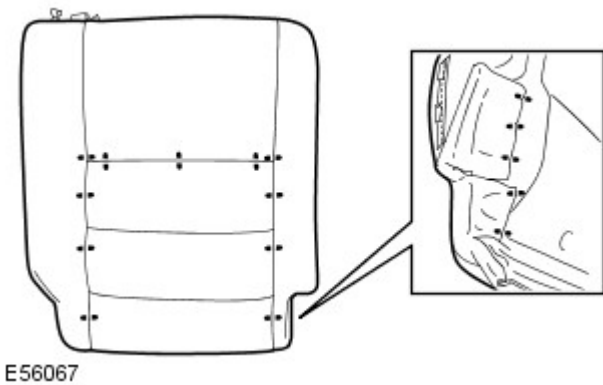

12. Remove the rear seat backrest cover.

- Remove the 16 hog rings.

Installation

1. Install the rear seat backrest cover.

- Install the 16 hog rings.

- Attach the 4 clips.
2. Install the rear seat backrest assembly.
 - Tighten the Torx bolts to 45 Nm (33 lb.ft).
 3. Connect the backrest heater mat electrical connector.
 - Attach the rear seat cushion side clip.
 4. Install the rear seat release handle finisher.
 - Tighten the screw.
 5. Install the rear seat release handle.
 6. Install the rear seat head restraint retaining clips.
 7. Install the rear seat head restraint.
 8. Install the luggage strap tether.
 9. Install the rear seat cushion side finisher.
 - Tighten the screws.
 10. Install the outer backrest hinge cover.
 - Tighten the screws.
 - Tighten the screw.
 11. Install the inner backrest hinge cover.
 - Attach the clips.
 - Tighten the screw.
 - Attach the backrest cover side clip.